

- T1 - Amelanchier (grafted to prunus prunus trunk) height 5.5m high
- T2 - Lilo Dendron (Tulip) 13.5m high.
- S1 - Shrubs/hedges of varying heights.
- S2 - 2m high privet hedge.
- - Tree protection zone.



PROTECTIVE FENCING. THIS FENCING MUST BE MAINTAINED IN ACCORDANCE WITH THE APPROVED PLANS AND DRAWINGS FOR THIS DEVELOPMENT.



TREE PROTECTION AREA KEEP OUT!
 (TOWN & COUNTRY PLANNING ACT 1990)
 TREES ENCLOSED BY THIS FENCE ARE PROTECTED BY PLANNING CONDITIONS AND/OR ARE THE SUBJECTS OF A TREE PRESERVATION ORDER. CONTRAVENTION OF A TREE PRESERVATION ORDER MAY LEAD TO CRIMINAL PROSECUTION
 ANY INCURSION INTO THE PROTECTED AREA MUST BE WITH THE WRITTEN PERMISSION OF THE LOCAL PLANNING AUTHORITY

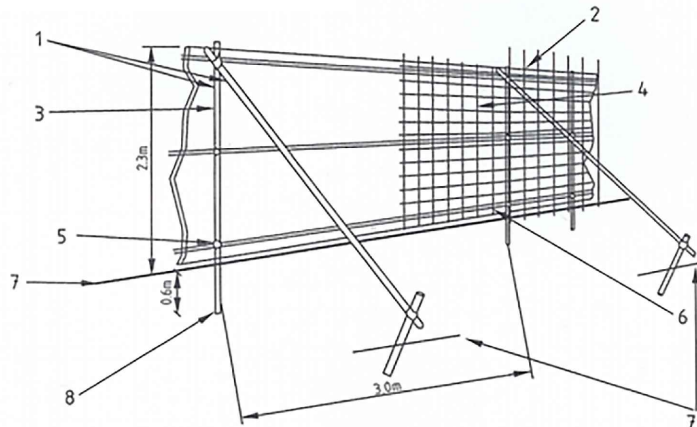

- 1 Standard scaffold poles
- 2 Uprights to be driven into the ground
- 3 Panels secured to uprights with wire ties and, where necessary, standard scaffold clamps
- 4 Weldmesh wired to the uprights and horizontals
- 5 Standard clamps
- 6 Wire twisted and secured on inside face of fencing to avoid easy dismantling
- 7 Ground level
- 8 Approx. 0.6m driven into the ground

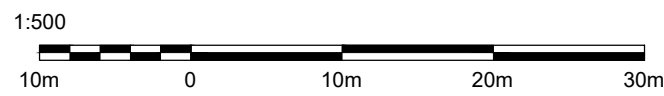
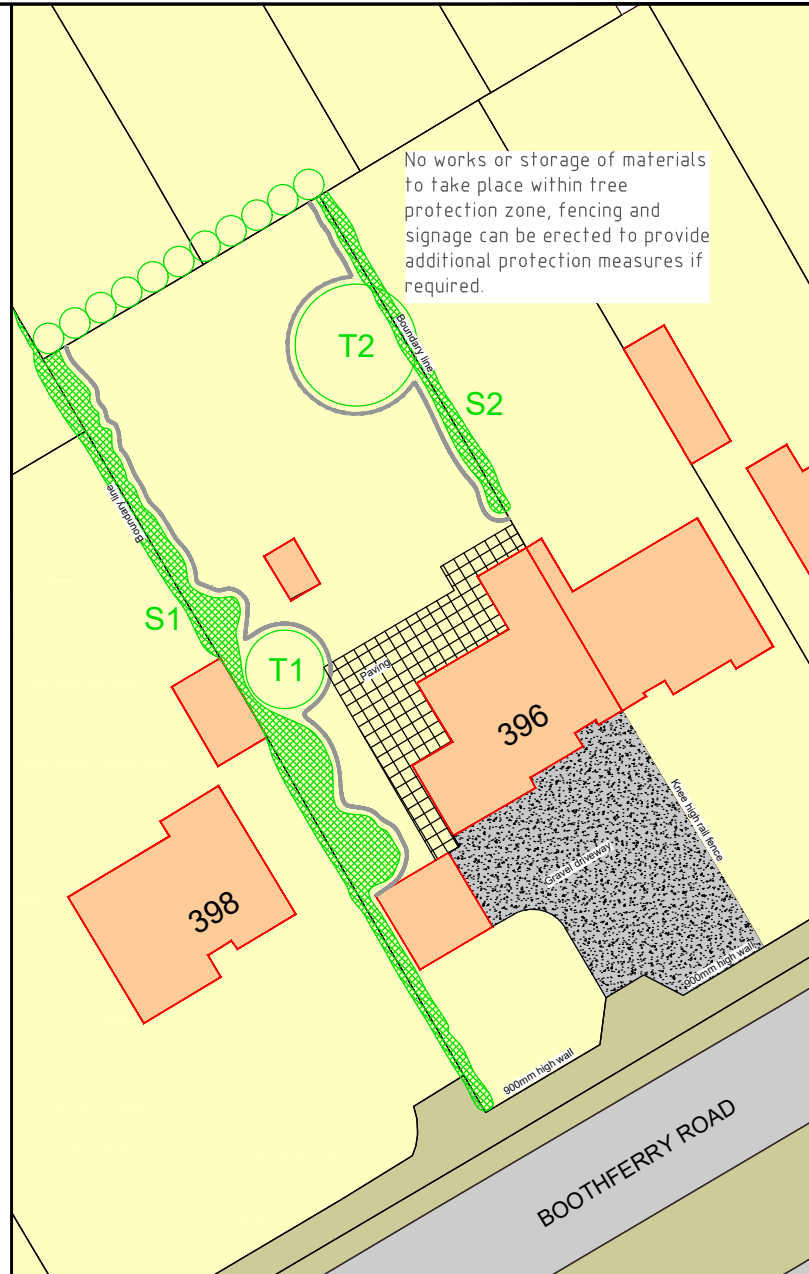

8 Kensington Avenue, Kingswood Parks,
 Kingston upon Hull, East Yorkshire, HU7 3AF
 Phone: 01482 833057 Mobile: 07968 208363
 Email: info@sayarchitectural.co.uk
 www.sayarchitectural.co.uk

Client:
 Mr Stephenson

Address:
 396 Boothferry Road
 Hessle
 East Yorkshire

Drawing no:
 023-010-005

Rev:
 A

Drawing title:
 Tree Survey and
 Protection Information

Status:
 Design
 Planning
 Preliminary Building Regulations
 Building Regulations
 Construction
 As-Built

Rev:	Description:	Date:
A	Boundary treatments and hardstanding information added.	16.02.2024
-	-	-
-	-	-
-	-	-