

proposed door head detail

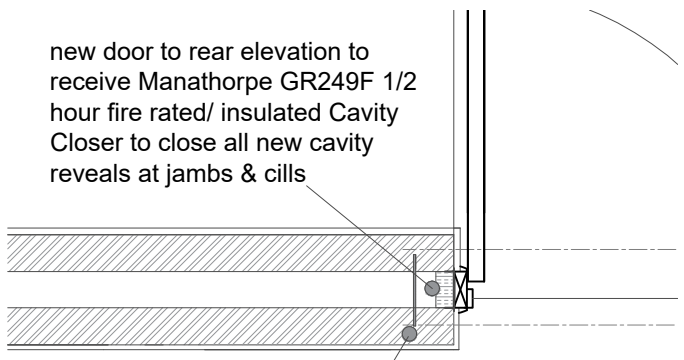

proposed door jamb detail

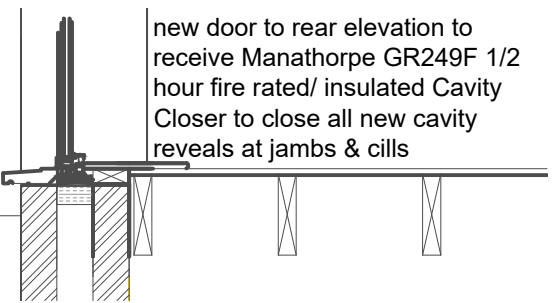

proposed door threshold detail

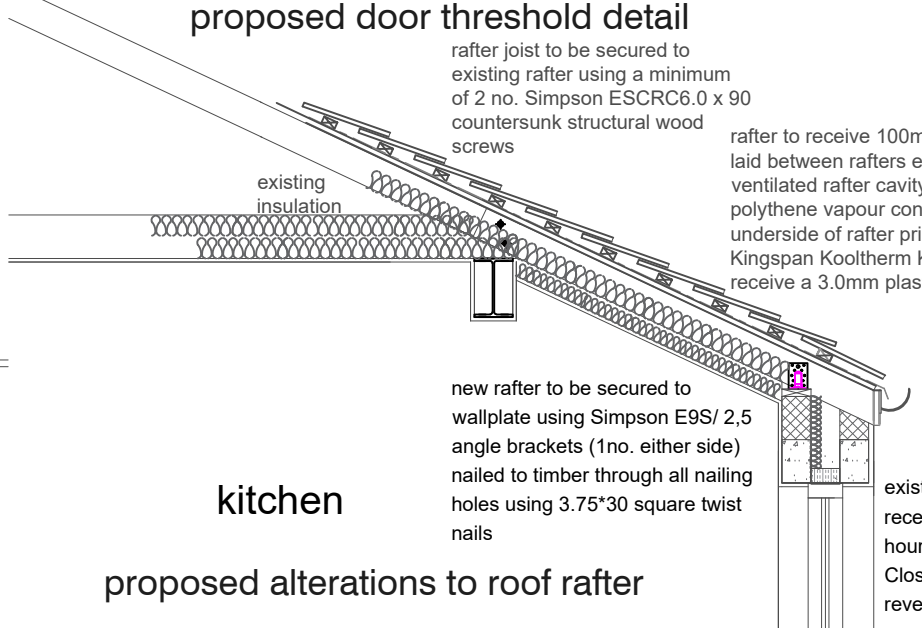

kitchen
proposed alterations to roof rafter

on formation of new opening contractor to install Helifix dryfix Dry mechanical pinning and remedial tying system at 225mm c/c (each jamb) over height of new opening, ties to be installed no more than 75mm from face of newly formed jamb.

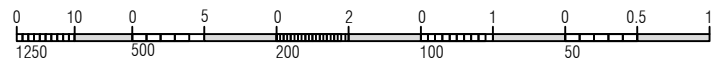

| REVISION | DESCRIPTION | DATE |
|---|-------------------|--------------------|
|  Structural Engineers & Design Consultants <small>The foundation of your project</small> | | |
| EZY ENGINEERING THE FUNDAMENTA GROUP CLYDE OFFICES, 48 WEST GEORGE STREET, GLASGOW, G2 1BP Tel: 07456929746 Email: ezy@fundamentagroup.co.uk | | |
| PROJECT FUN/CAI/01 PROPOSED INTERNAL ALTERATIONS & ALTERATIONS TO REAR ROOF 1 CAIRNGORM ROAD, GLASGOW | | |
| TITLE DETAILS | | |
| DRAWN BY RC | CHECKED BY BA | DATE 23/02/2024 |
| DRAWING NUMBER D/01 | REVISION SCALE | A NTS |
| STATUS FOR APPROVAL | | |