



### Evolve VS windows – key features:

- Low maintenance PVC-U frames with traditional styling
- A-rated as standard, with B or C also available (*optional*)
- BSI Kitemarked
- Fully featured sculptured profiles
- Equal sight lines for top and bottom sashes
- Choice of Georgian glazing bar designs
- Easy-clean tilt facility, with tilt restrictors for safety
- Double glazed with 24mm glass
- Choice of sill sizes available: 154mm (*standard*), 150mm, 180mm and 225mm
- Sill jointers for professional detailing
- Decorative and run through sash horns (*optional*)
- Trickle vents (*optional*)
- Anti-jemmy security bar (*optional*)
- Sash child/travel restrictors (*optional*)
- Deep bottom rail for period styling (*optional*)
- CE Marked
- Guaranteed for 10 years

### Energy efficiency

Incorporating brush seals around the openings for effective weatherproofing and draught exclusion, Evolve VS sash windows have an A window energy rating (WER) as standard and optional A+, B or C WER ratings can be specified.

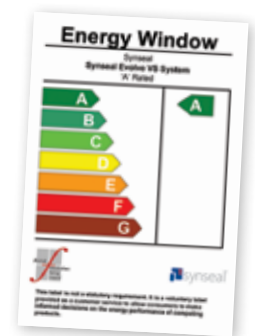

Evolve VS windows are lead free and choosing PVC-U over timber is an environmentally-friendly selection as the majority of end-of-life PVC-U windows can be recycled over and over again to produce new windows.

### Double glazing units

Evolve VS sash windows are glazed with 24mm DG units as standard (4:16:4 pane and airgap configuration with Argon gas filling and Warm Edge spacer bar). Specification options include toughened or laminated Low-E glass for enhanced thermal performance. Diamond, square leaded, Georgian and Astragal bar options and obscured patterned glasses for added privacy are available.



# Cross section: Evolve VS windows

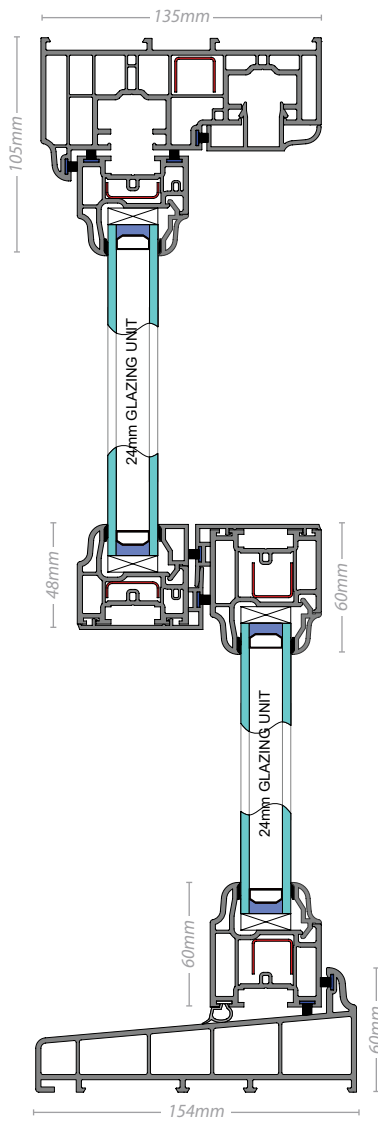

Vertical section through sash with standard sill

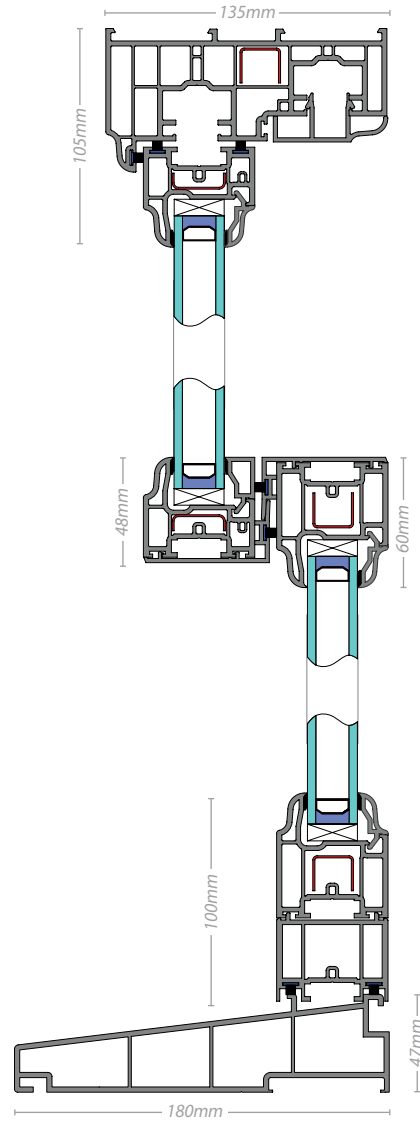

Vertical section through sash with DBR and non standard sill option

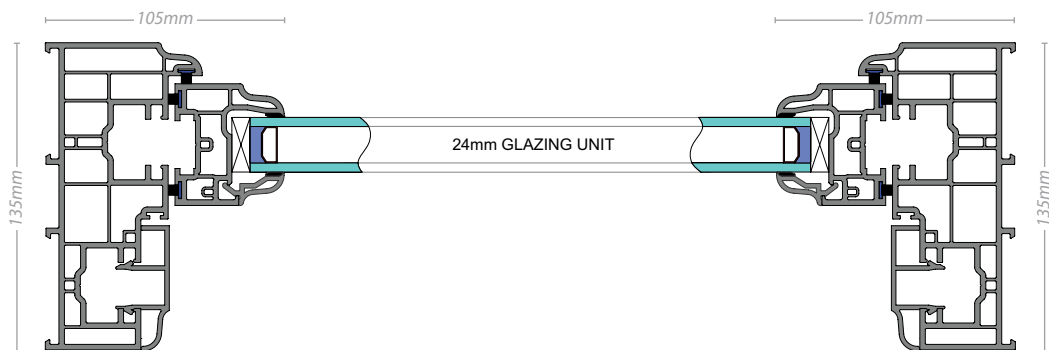

Horizontal section through top sash

## Colour options & hardware

### Solid colours

Evolve VS windows are available in the following PVC-U profile colour:

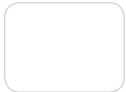

White

### Woodgrain colours

Foiled finishes are also available to enhance Evolve VS windows with glossy, freshly-painted colour woodgrain or authentic woodgrain effects:



Golden Oak



Golden Oak on White



Cherrywood



Cherrywood on White

### Artisan woodgrain collection

Evolve VS windows are available in the following Artisan colours and can be specified with White PVC-U on inside faces and woodgrain foiled finish on outside faces, see below:

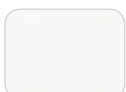

Woodgrain White



Cream



Cream on White



Irish Oak



Irish Oak on White



Chartwell Green



Chartwell Green on White



Grey



Grey on White



Black/Brown



Black/Brown on White

### Hardware

Evolve VS hardware is available in White, Gold, Chrome and Satin Chrome finishes. High quality balance weights and hardware are securely fixed to integral window frame reinforcements for reliable and smooth sliding sash operation, time after time.



Pole eye - White



Lock - Satin Chrome



Sash lift - Gold



Sash lift - Chrome



Run through sash horns



Tilt restrictor

### Glazing Bars

To achieve a traditional appearance, Evolve VS sash windows can be manufactured with a choice of internal or external Georgian glazing bars. Run through sash horns provide another decorative option for a truly authentic look.



Astragal bars - applied to the internal and external surface



Georgian bars - 18mm or 25mm (fitted between panes of glass)

### Trickle Vents

Slimline trickle ventilators can be fitted into the head of the top sash in the Evolve VS window to provide air flow and reduce condensation. 2000 or 4000mm<sup>2</sup> trickle vent options can be specified in White, Brown or Caramel colours to provide ventilation and meet Building Regulations Part F1 for new dwellings. Alternatively, modular design trickle vents that clip neatly together can be incorporated to cater for wider window frames and provide 8000mm<sup>2</sup> of ventilation, if required.

# Window style options

**Evolve VS windows are available in a variety of glazing bar configurations and shaped frame designs to suit the style of every property, including sizeable units for commercial buildings.**

Equal sized top and bottom sashes (50/50 split) are standard, however windows can be manufactured with other split ratios to specification (minimum transom drop: 350mm).

**Evolve VS window sizes:**

Minimum width/height: 350mm x 800mm  
 Maximum width/height: 1500mm x 2500mm

**Fire escape minimum sizes:**

Minimum width/height: 750mm x 1350mm  
*\*Using constant force springs.*

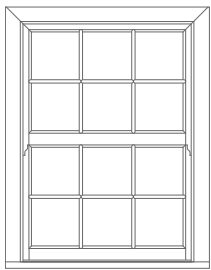

1/2

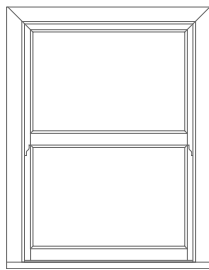

Non-bar

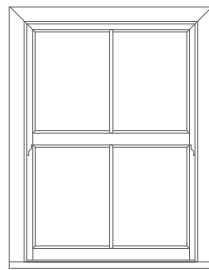

Centre bar

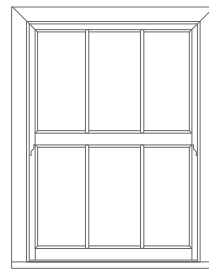

Three Light

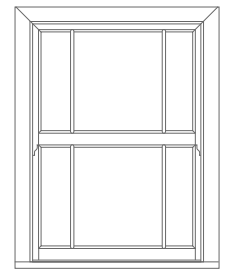

Offset Three Light

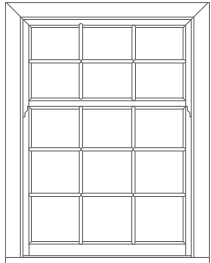

2/5 x 3/5

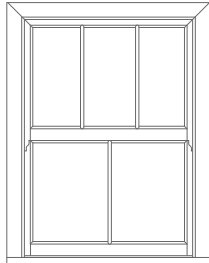

Asymmetric

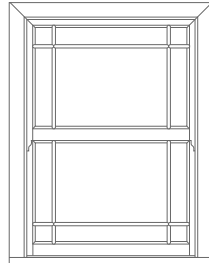

Margin

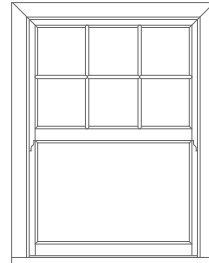

Half Georgian

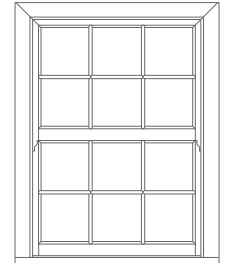

Georgian

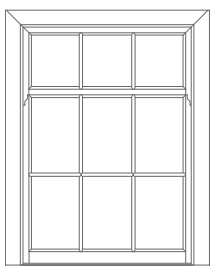

1/3 x 2/3

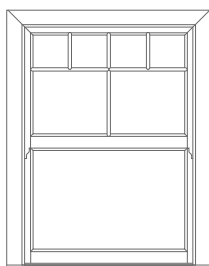

Georgian Variant

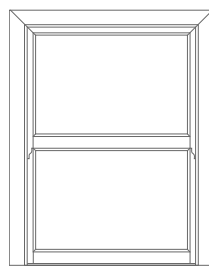

Fire Egress A

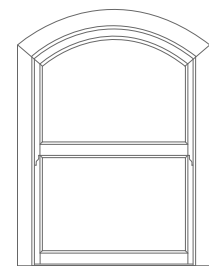

Swept Head

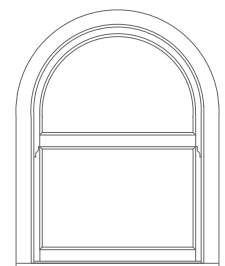

True Arch

**Bays and coupled windows also available - please ask for details**

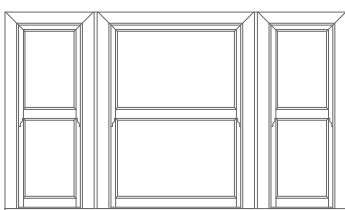

Style 2

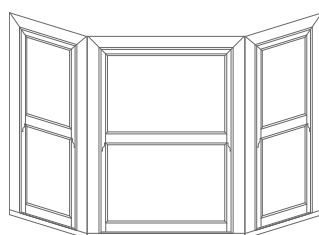

Tripartite - Style 3

90° and variable angle bay posts are also available for bay window applications.



Both sashes tilt open independently, for easy access to clean inside and out



Both sashes slide up and down, for cleaning access and ventilation



## Evolve bi-fold doors - elegant doors creating flexible and modern spaces for both living and working environments

**Contemporary bi-fold doors combine elegance with flexibility, allowing design of panoramic view wide-span door openings to create versatile spaces.**

Evolve bi-fold doors are precision engineered to the highest standards and available in a variety of finishes and folding leaf combinations. PVC-U door sashes slide along a thermally-broken aluminium top and bottom track system, designed to ensure years of trouble-free service. Rigid aluminium tracks increase the structural strength and enable easy transportation, preventing excessive flex to ensure that the doors run smoothly, even on long spans with multiple leaf configurations.

Fully-manufactured by Synseal using a choice of either Shield or Legend ovolo PVC-U profiles, Evolve bi-fold doors are energy-efficient and easy to maintain once installed.



Cross section showing bi-fold aluminium bottom track

### Evolve bi-fold doors - key features:

- Bi-fold door is supplied fully assembled for easy installation
- Thermally-broken top and bottom aluminium tracks
- High quality Siegenia gearing
- PVC-U door frames available in a choice of single or dual-colour finishes
- Aluminium tracks and hinge covers available in White or Brown finish
- Hardware and flag hinges available in White, Polished Gold or Polished Chrome finishes
- Choice of PVC-U frame profiles: Shield or Legend ovolo
- Choice of door designs: open-in or open-out
- Sealing weatherstrips conceal unsightly gasket lines for a professional finish
- Double glazed as standard with 28mm toughened clear glass
- U-value: 1.7 W/m<sup>2</sup>K
- Choice of glazing bead styles: chamfered or sculptured ovolo
- Doors can also be supplied unglazed (optional)
- Choice of sill sizes: 85mm and 150mm
- Sill track trims for improved aesthetics (optional)
- Trickle vents fitted to first and last door sashes (optional)
- CE Marked
- Guaranteed for 10 years

### Solid and woodgrain colours



*The colours shown are designed as a guide only. Before making a final selection, please ensure you have seen a foil swatch.*