

**1 Ground Floor**  
1 : 50

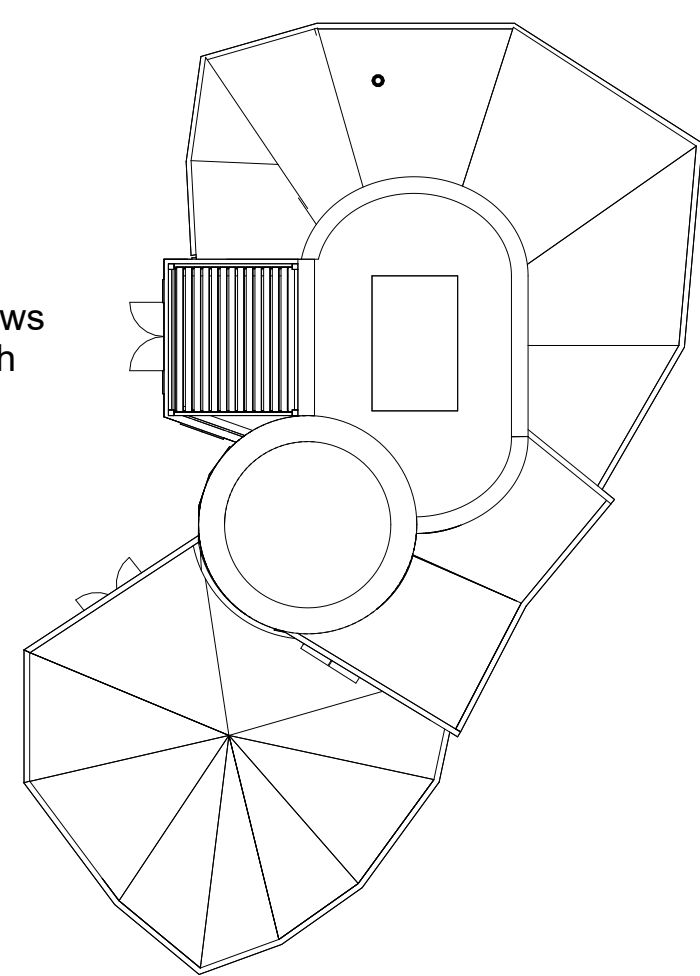

**3 Site**  
1 : 200

Windows not shown due to cut through

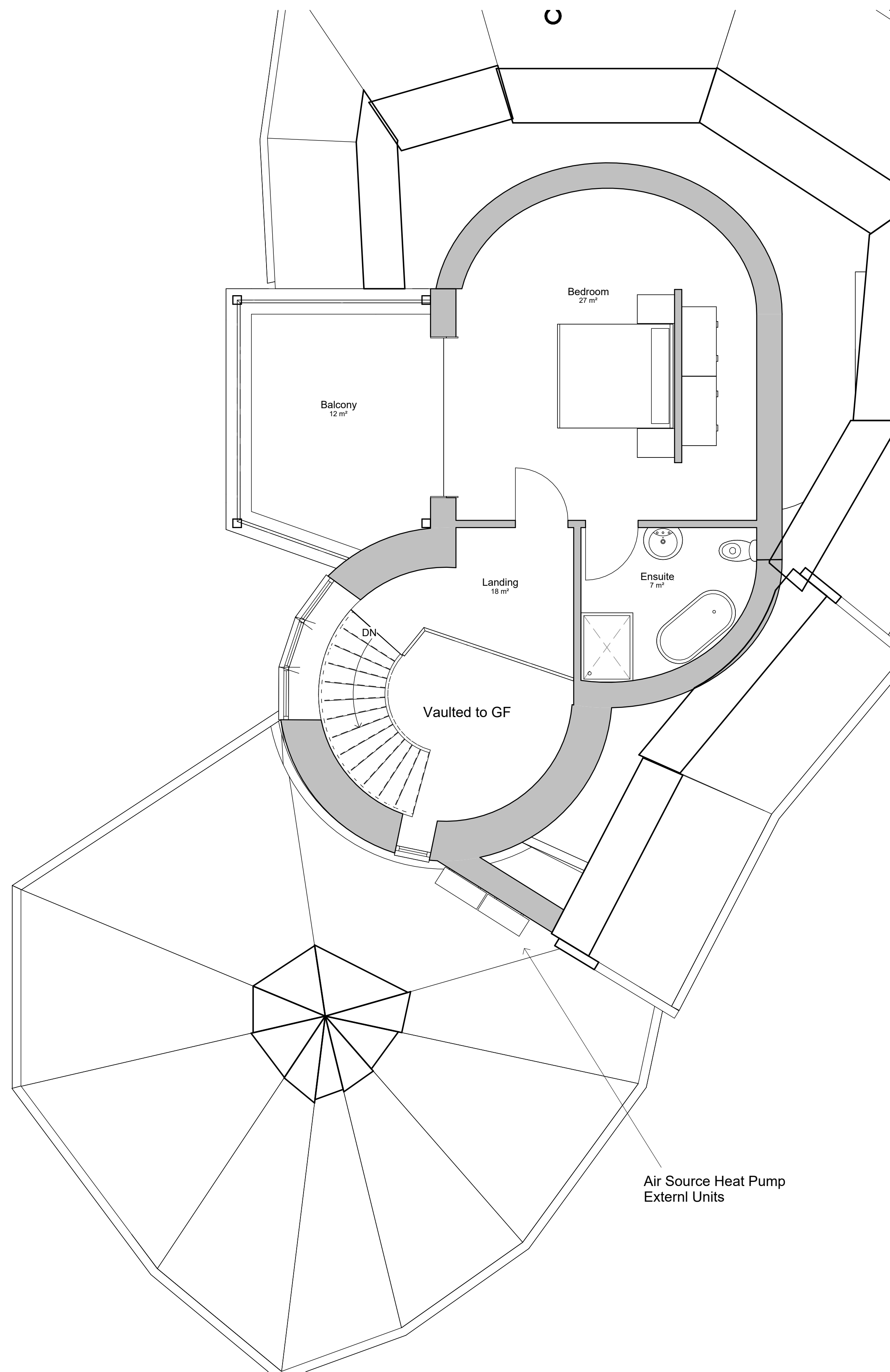

**2 First Floor**  
1 : 50

**GENERAL NOTES & SPECIFICATIONS**

MATERIALS, WORKMANSHIP AND CONSTRUCTION ARE TO CONFORM WITH CURRENT STANDARDS, CODES OF PRACTICE, AGREEMENT CERTIFICATES AND MANUFACTURERS RECOMMENDED SPECIFICATIONS AND ARE TO FULLY COMPLY WITH THE BUILDING REGULATIONS 1991, RELATED APPROVED DOCUMENTS AND LEGISLATION.

ALL SERVICES ARE TO BE INSTALLED IN ACCORDANCE WITH STATUTORY AUTHORITY REGULATIONS AND BY-LAWS.

**SAFETY**

STATUTORY INSTRUMENT 2015 No 51 - THE CONSTRUCTION (DESIGN AND MANAGEMENT) REGULATIONS 2015

THE CONTRACTOR IS TO COMPLY WITH THE DUTIES IMPOSED ON HIM BY THE ABOVE REGULATIONS AND LIAISE DIRECTLY WITH THE CDM COORDINATOR AS APPOINTED BY THE CLIENT

**IMPORTANT**

DO NOT SCALE FROM THIS DRAWING. WRITTEN DIMENSIONS ARE IN ALL CASES TO BE PREFERRED TO SCALED DIMENSIONS. ANY DISCREPANCIES ARE TO BE NOTIFIED TO THE DESIGNER AT ONCE.

THIS DRAWING IS SUBJECT TO COPYRIGHT AND MAY NOT BE COPIED OR DISCLOSED EITHER WHOLLY OR IN PART WITHOUT THE WRITTEN CONSENT OF McCARTNEYS LLP.

**RETENTION OF TITLE**

OWNERSHIP OF AND COPYRIGHT IN THE DESIGNS SHOWN ON THIS PLAN REMAIN VESTED IN McCARTNEYS LLP THE CLIENT IS LICENSED TO USE THE DESIGNS FOR THE PURPOSE FOR WHICH THEY WERE PRODUCED ON PAYMENT TO McCARTNEYS LLP OF THE COSTS OF PREPARATION OF THE PLAN AND DESIGNS.

**LICENCES**

Ordnance Survey  
LICENCE No: 100004120. REPRODUCED FROM THE ORDNANCE SURVEY MAP WITH PERMISSION OF THE CONTROLLER OF H.M. STATIONERY OFFICE. PUBLISHED FOR THE PURPOSE OF IDENTIFICATION ONLY AND ALTHOUGH BELIEVED TO BE CORRECT ITS ACCURACY IS NOT GUARANTEED. CROWN COPYRIGHT RESERVED

PROMAP  
LICENCE No: 10020449

| Rev | Description | Date |
|-----|-------------|------|
|     |             |      |
|     |             |      |
|     |             |      |
|     |             |      |
|     |             |      |



39 Broad Street, Newtown, Powys  
SY16 2BQ

PROJECT  
**Proposed Dwelling, Land at Round Oak Cottage, Burford, Tenbury Wells, WR15 8HW**

TITLE  
**Proposed Plans**

CLIENT  
**Ms D Wakeman**

DRAWN BY: GJ      CHECKED BY: GJ      DATE: March 2023

SCALE (@ A1): As indicated      PROJECT NUMBER: KI 5902

DRAWING NUMBER: **KI 5902 10**      REV: