

**EXG GROUND FLOOR**

(scale 1:100)

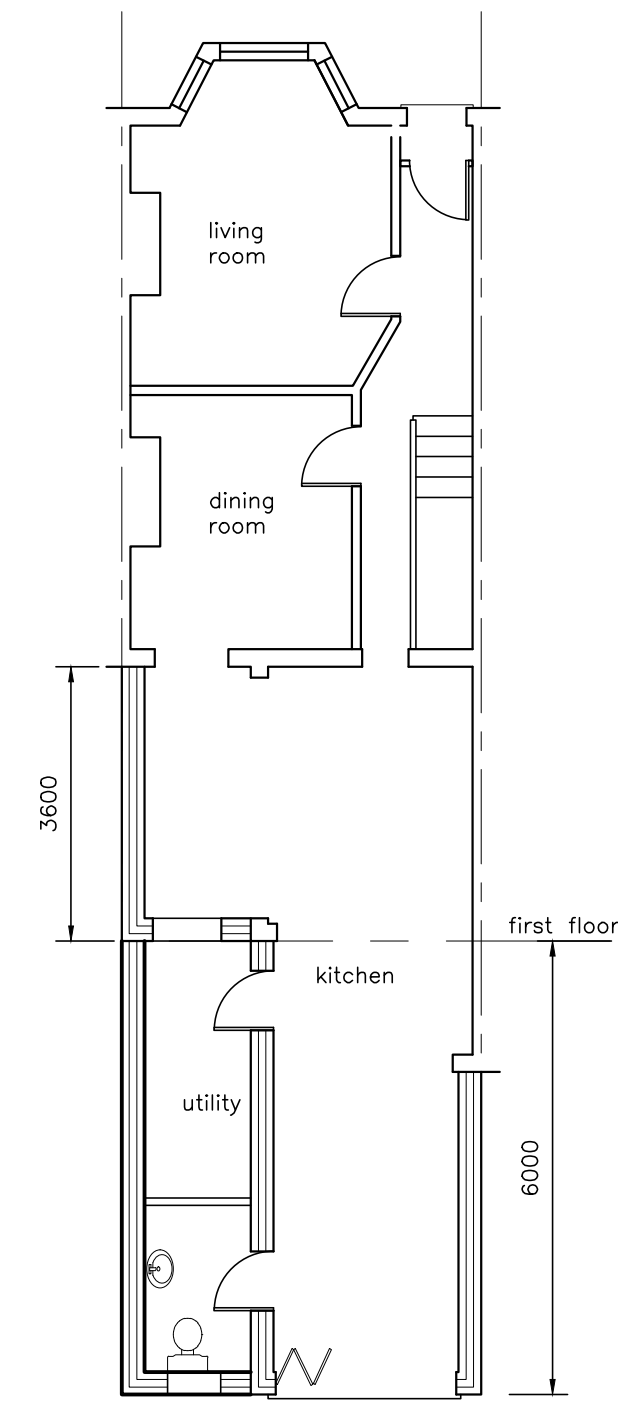

**PROPOSED GROUND FLOOR**

(scale 1:100)

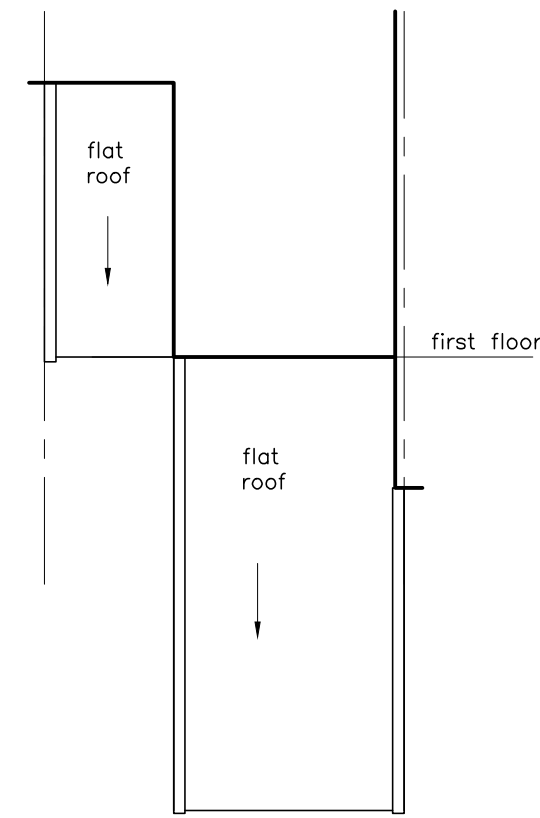

**EXISTING ROOF**

(scale 1:100)

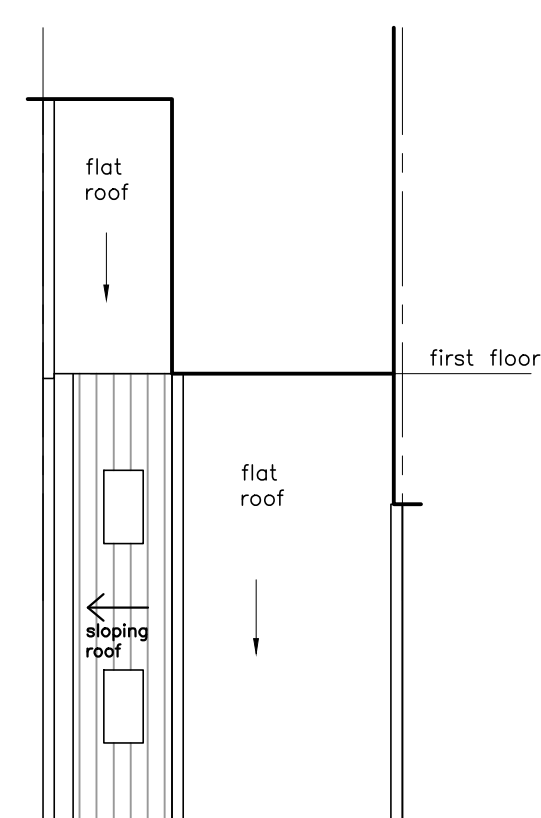

**PROPOSED ROOF**

(scale 1:100)

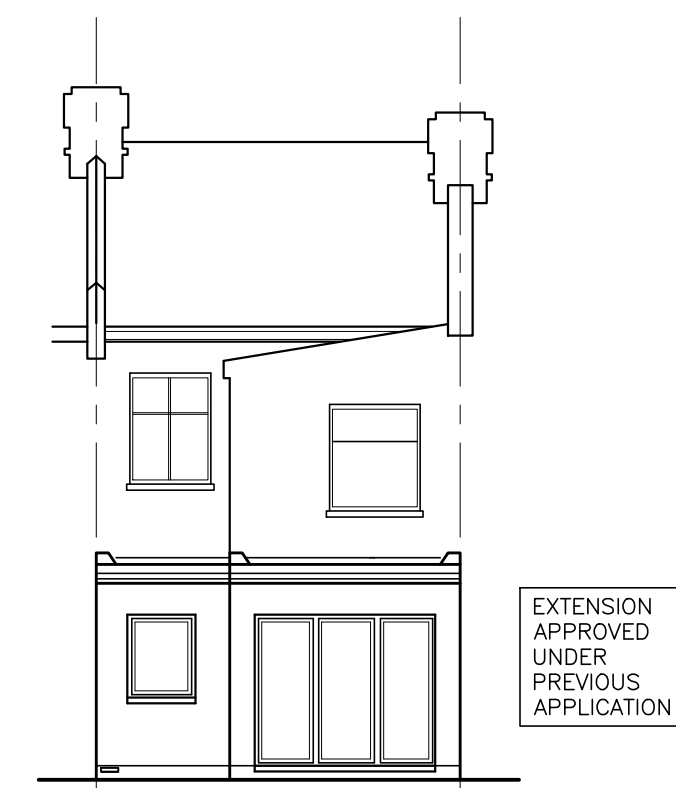

**EXISTING REAR**

(scale 1:100)

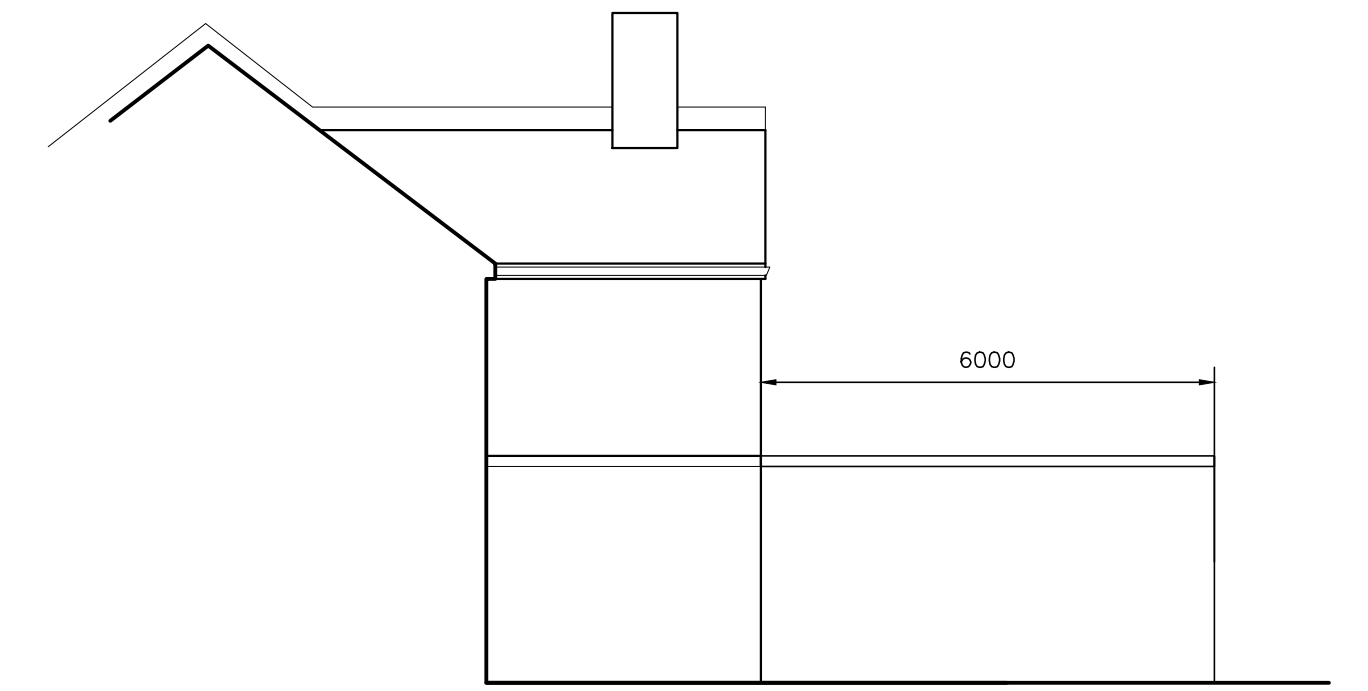

**EXISTING SIDE**

(scale 1:100)

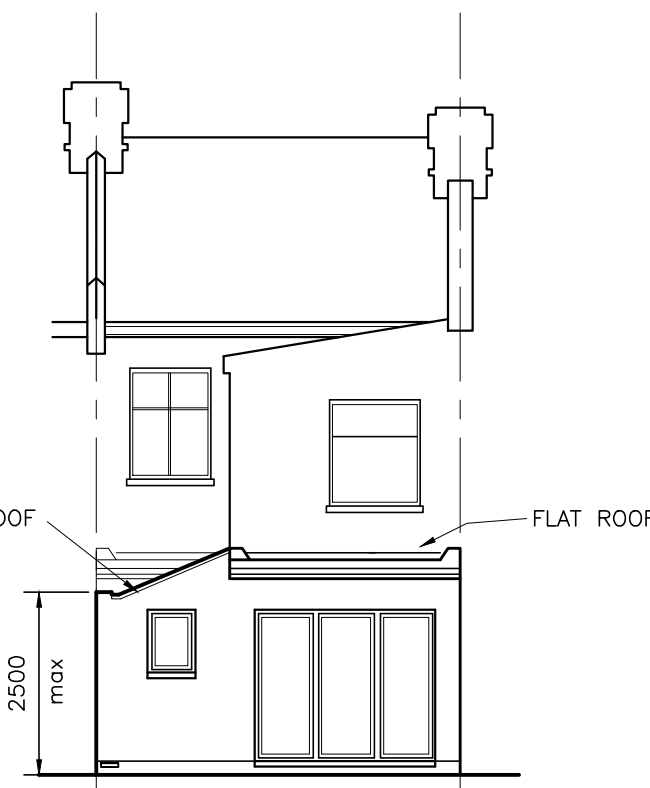

**PROPOSED REAR**

(scale 1:100)

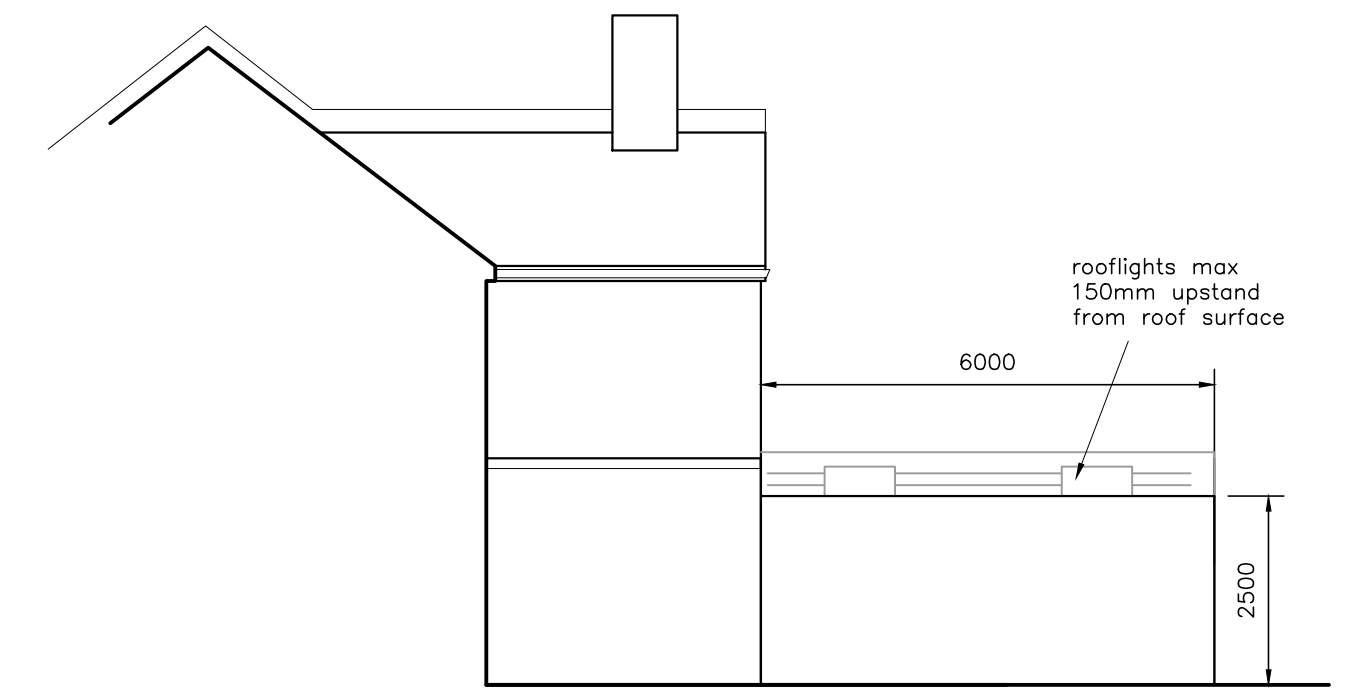

**PROPOSED SIDE**

(scale 1:100)

EXTENSION TO BE BUILT IN MATERIALS MATCHING THE MAIN HOUSE AND PREVIOUS EXTENSION

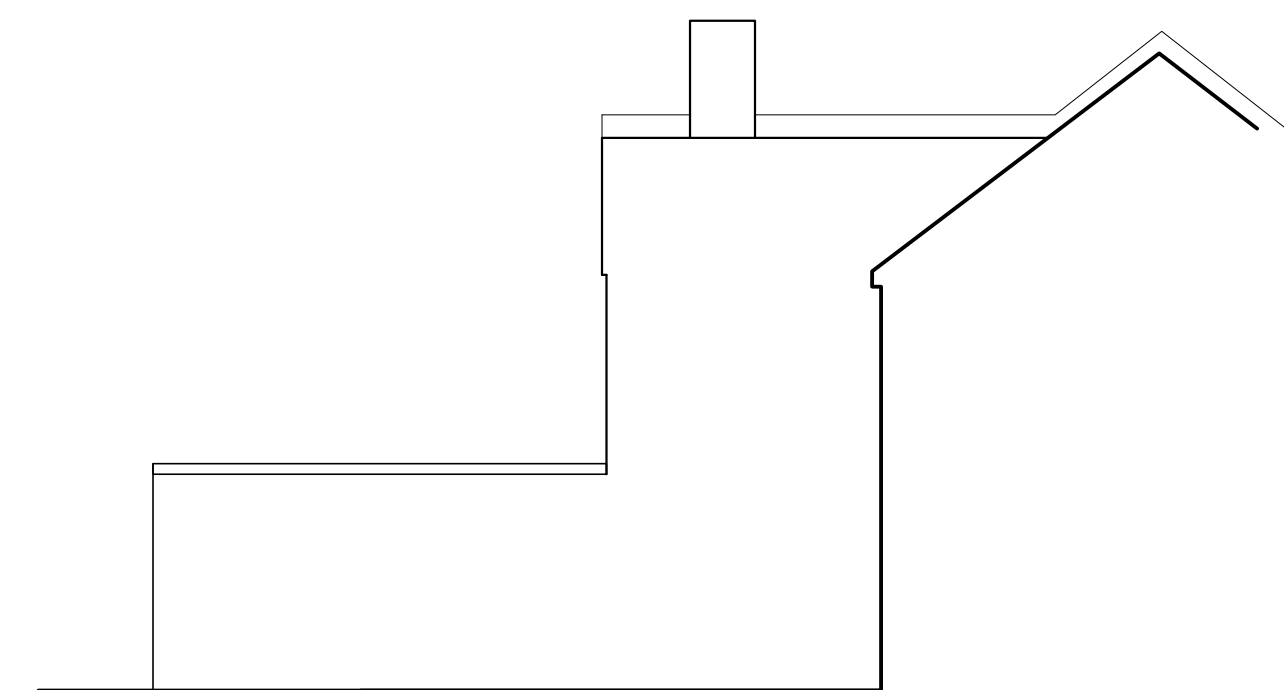

**EXISTING OTHER SIDE**

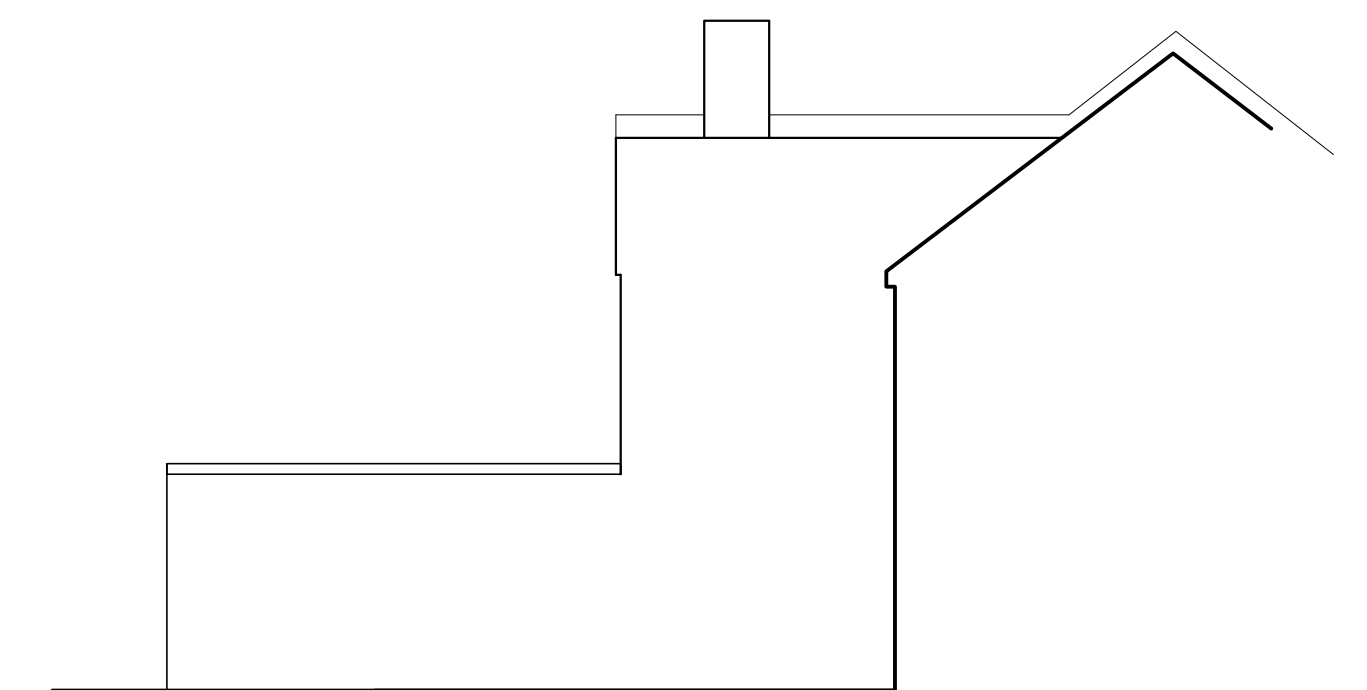

**PROPOSED OTHER SIDE**

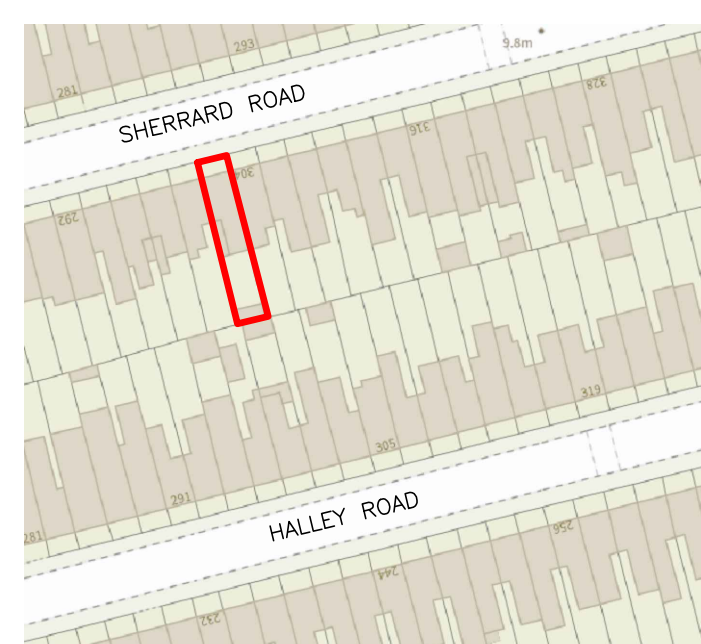

**LOCATION PLAN**

(1:1250)

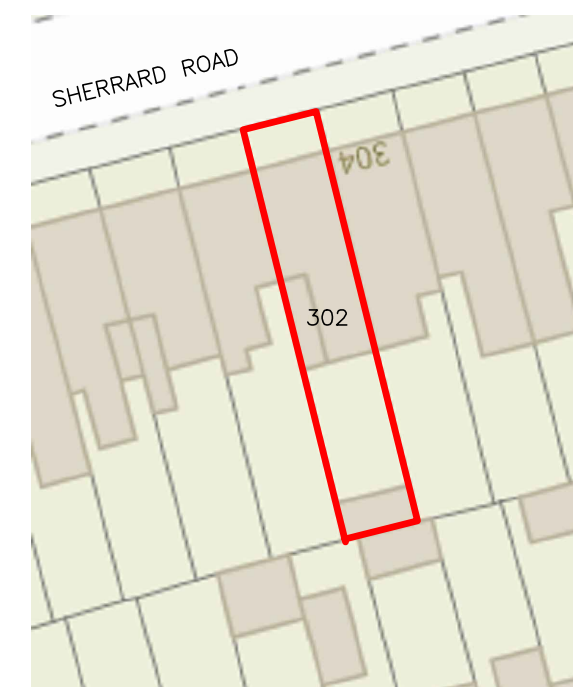

**BLOCK PLAN**

(1:500)

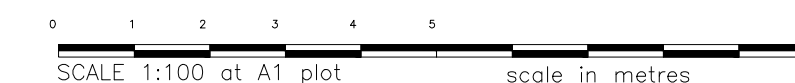

SCALE 1:100 at A1 plot scale in metres

REV A - FOR PLANNING

JOB  
**REAR EXTENSION**  
302 Sherrard Road, E12 6UF

TITLE  
**PLANS & ELEVATIONS**

SCALE 1:100	DRAWN	DATE feb 24	CHECKED
----------------	-------	----------------	---------

DRAWING N<sup>o</sup>. **4188-10**