

Door head

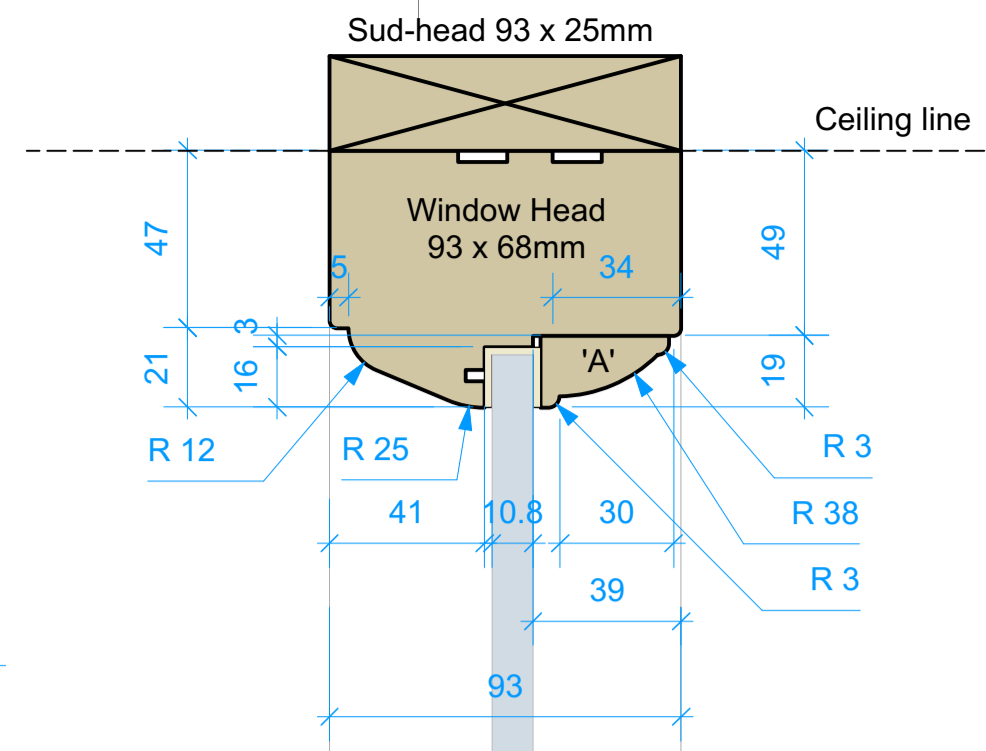

Direct glazed fanlight head above door and display windows internally beaded

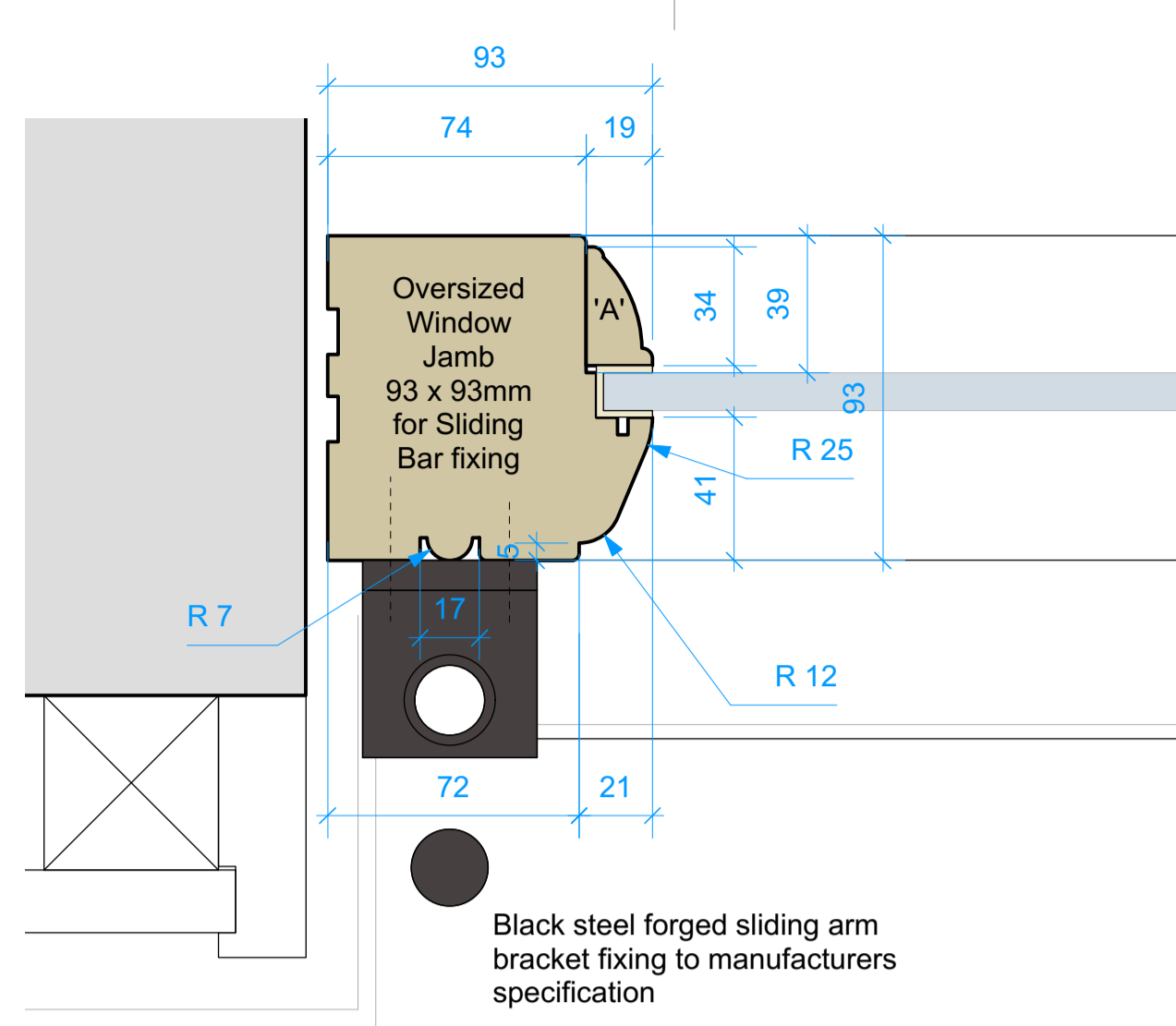

'LHS' WINDOW JAMB - PLAN VIEW

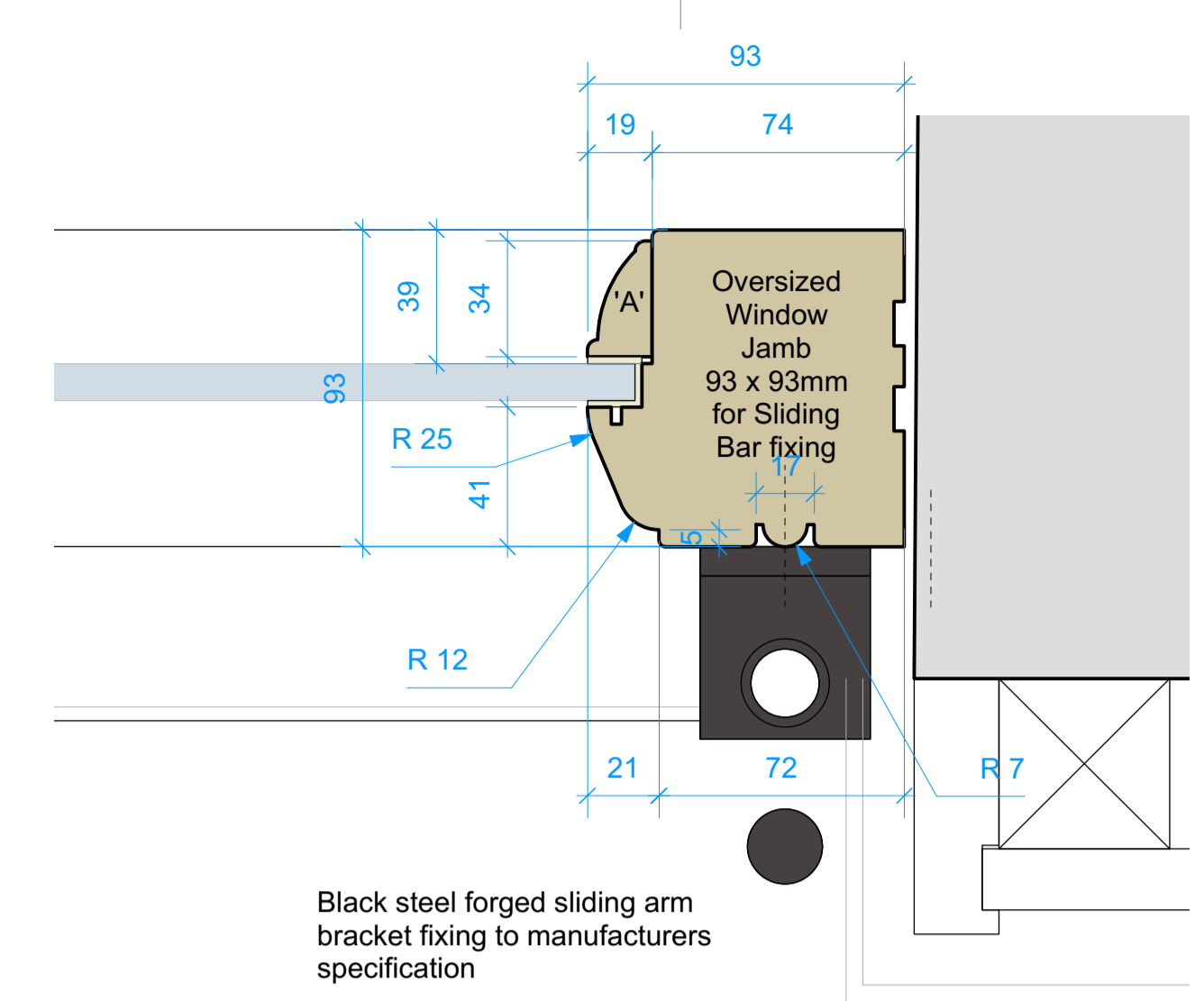

'RHS' WINDOW JAMB - PLAN VIEW

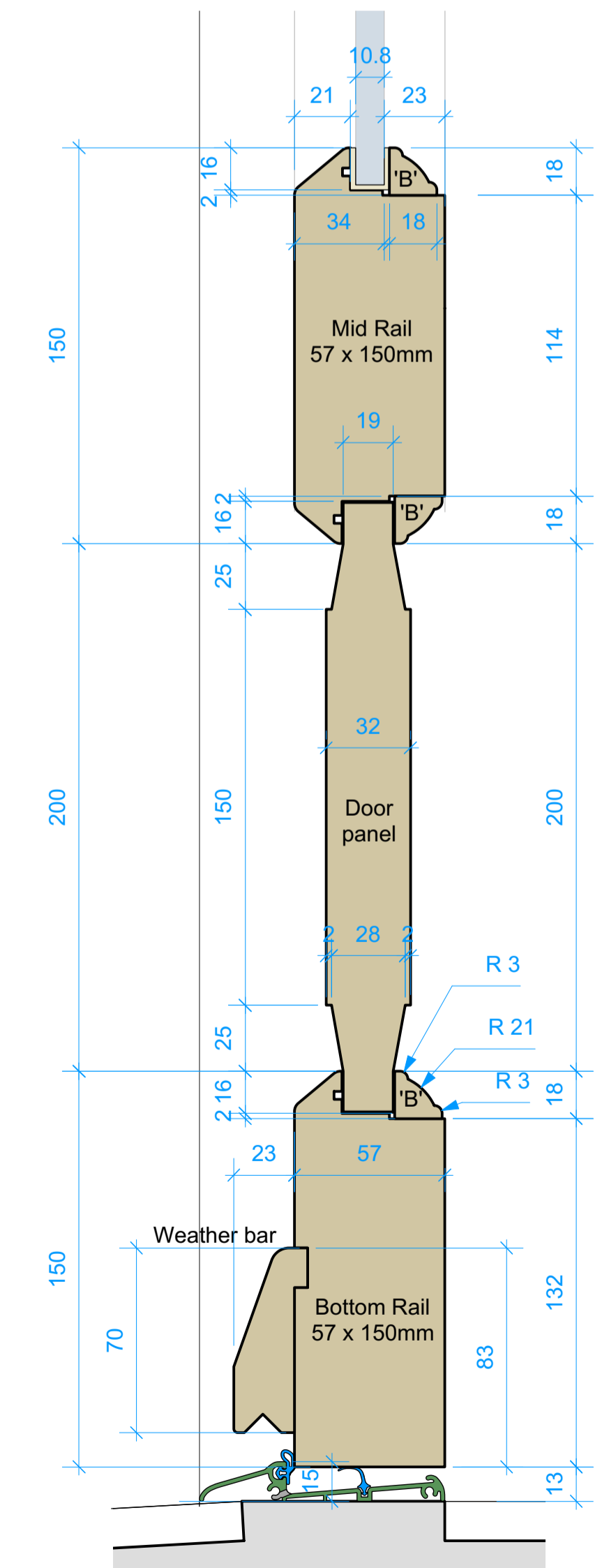

DOOR SECTION

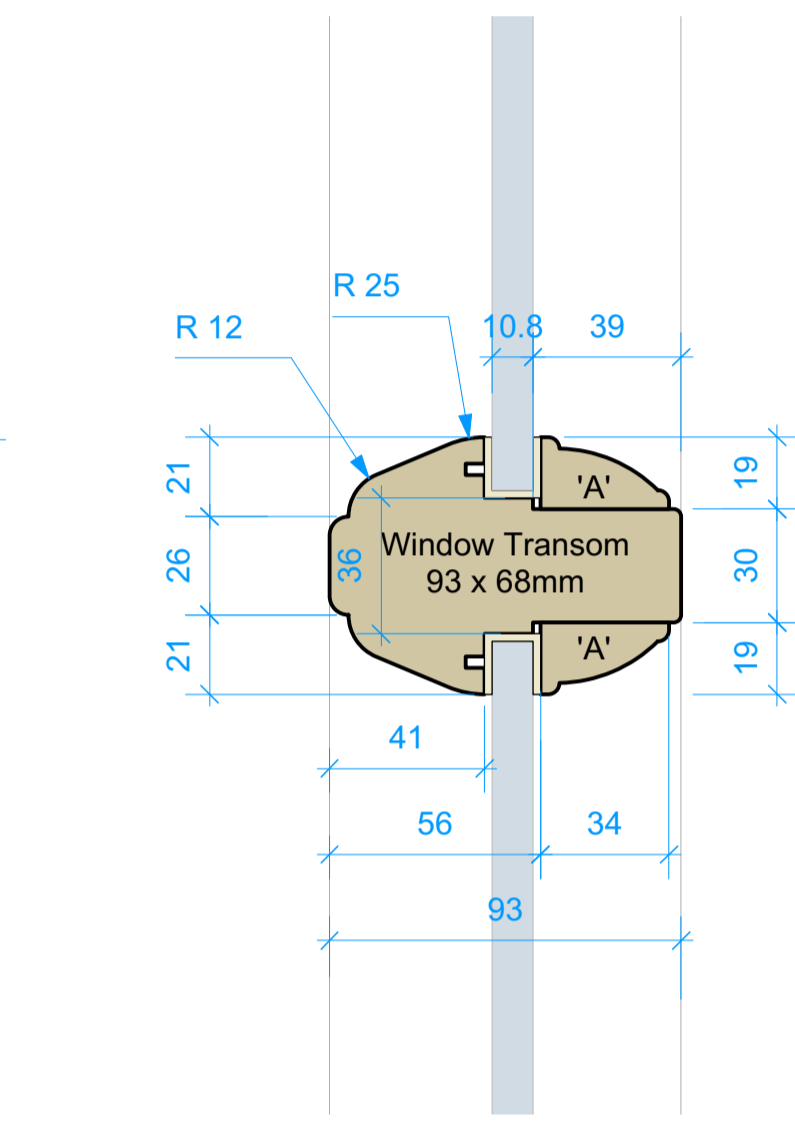

Direct glazed frame internally beaded

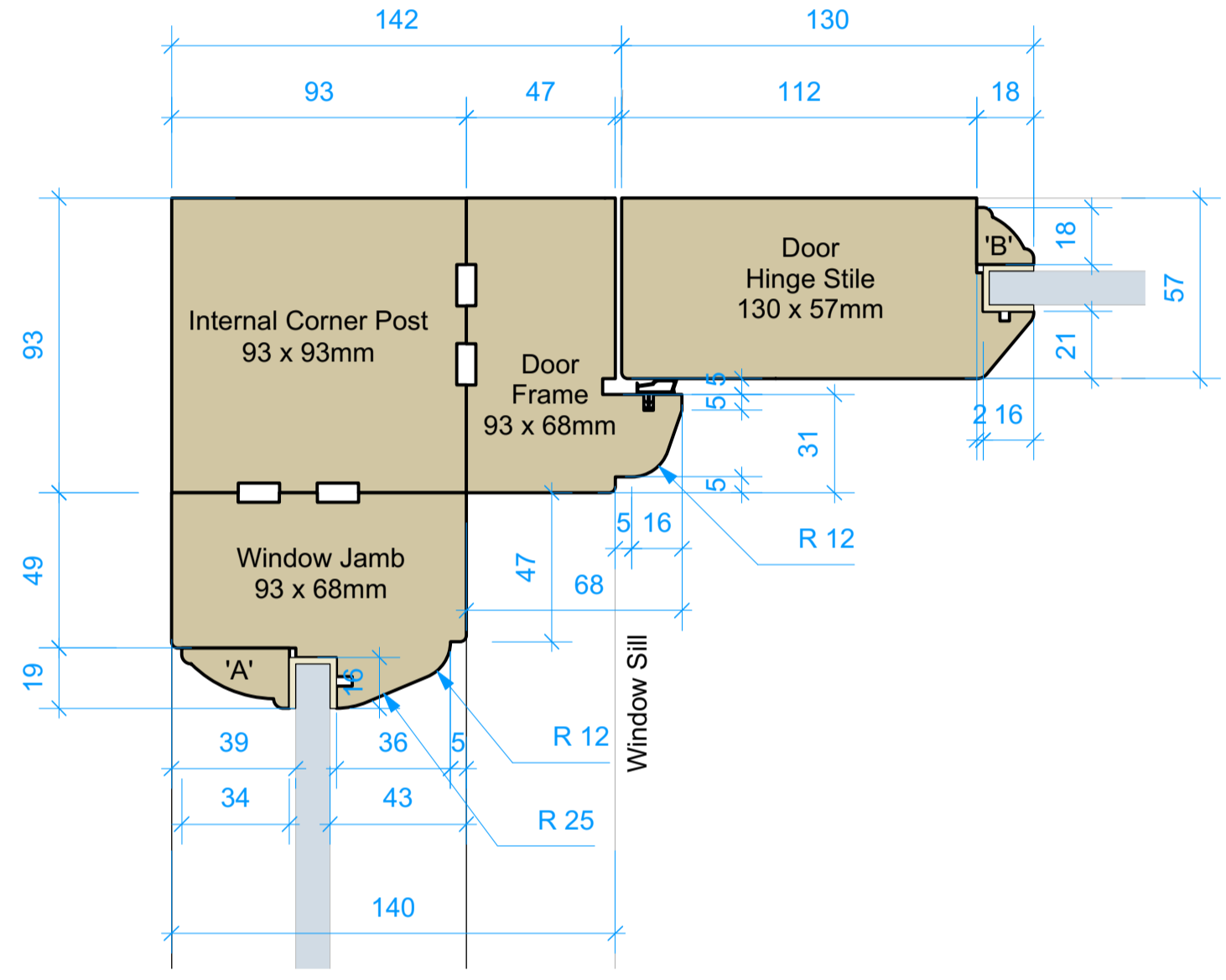

DOOR FRAME & WINDOW JAMB TO 'LHS' INTERNAL CORNER POST - PLAN VIEW (Door leaf shown closed)

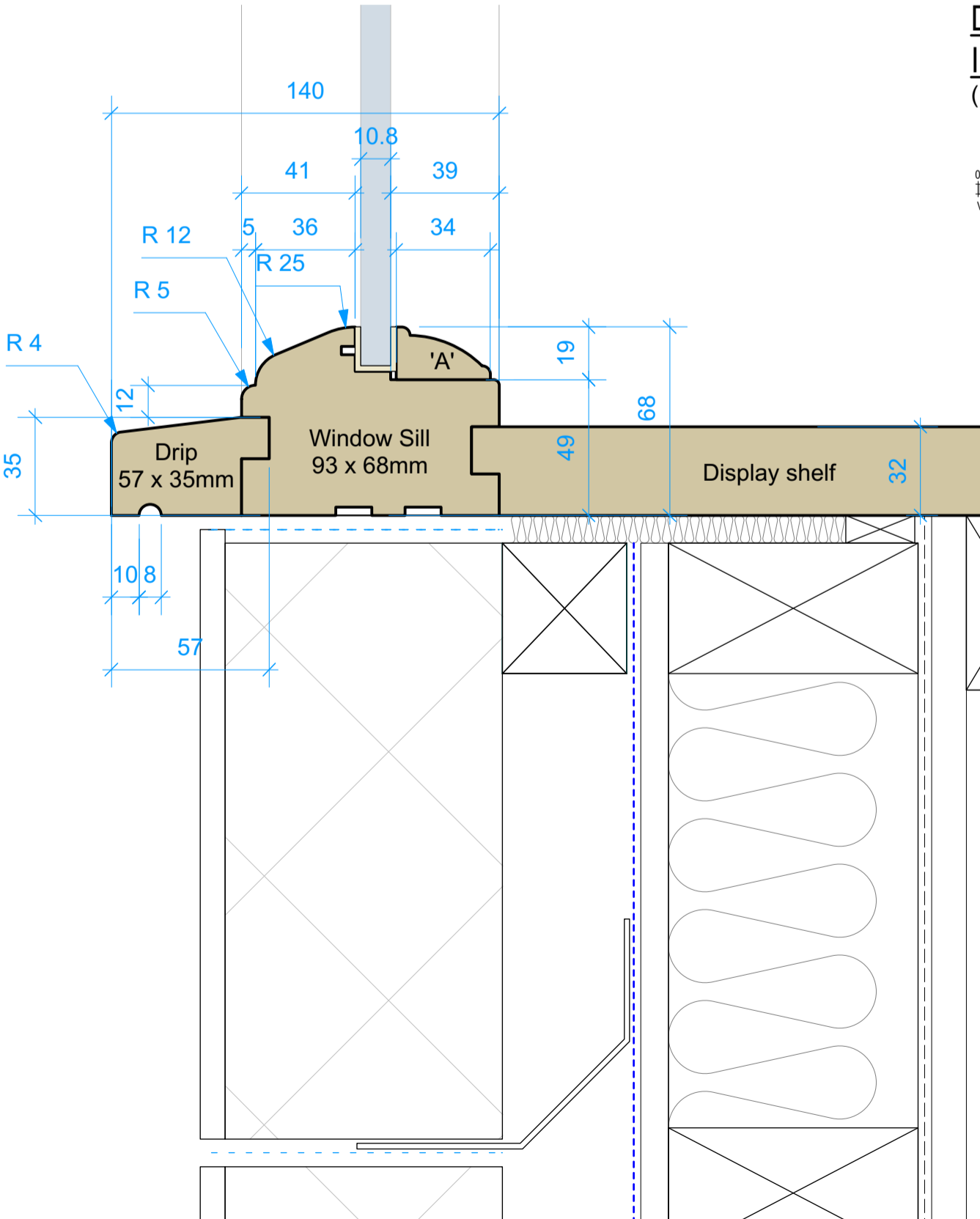
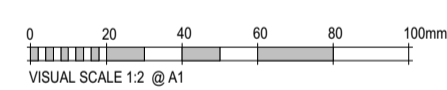

WINDOW SECTION

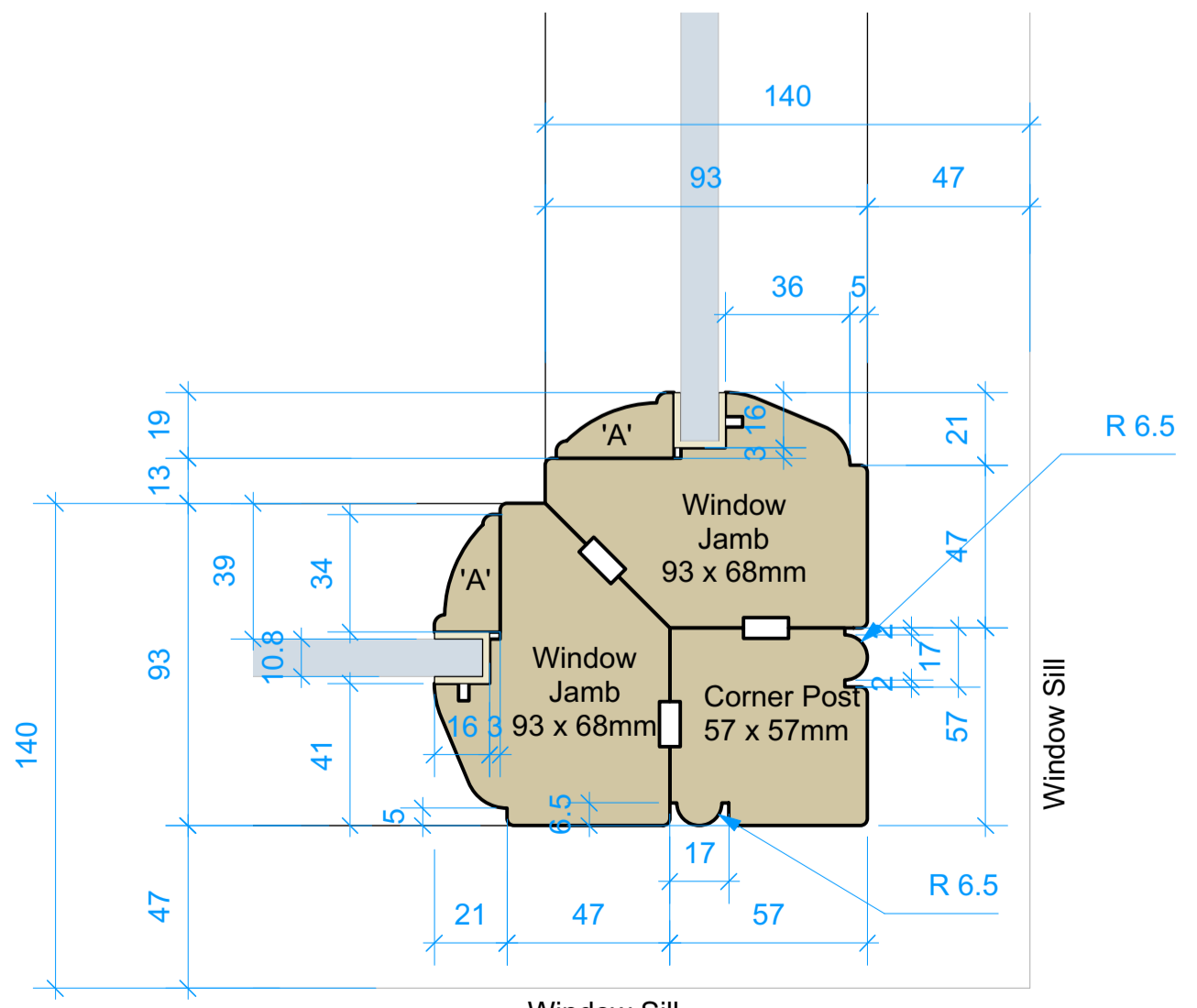

LHS WINDOW JAMB TO OUTER CORNER POST - PLAN VIEW

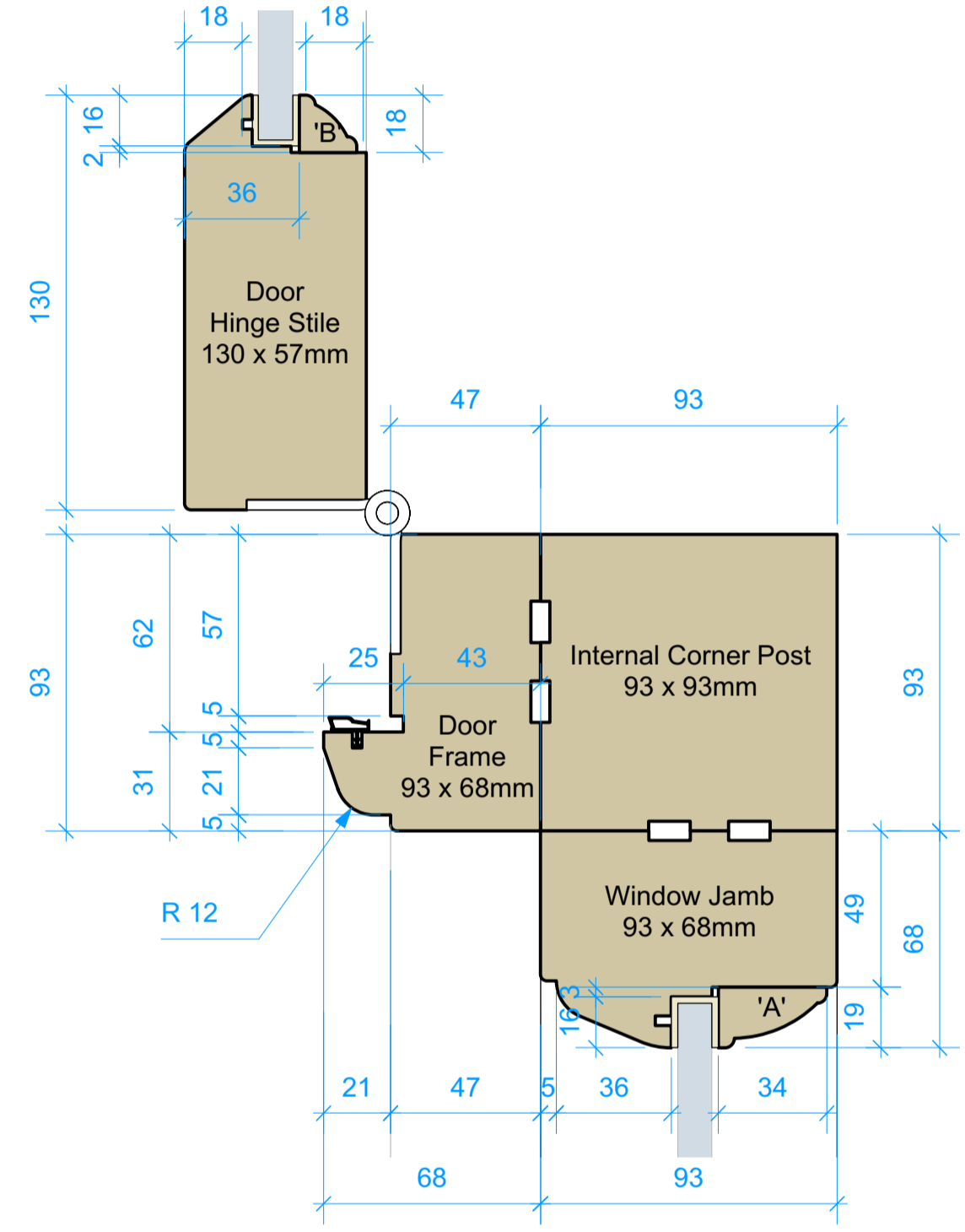

DOOR FRAME & WINDOW JAMB TO 'RHS' INTERNAL CORNER POST - PLAN VIEW (Door leaf shown open)

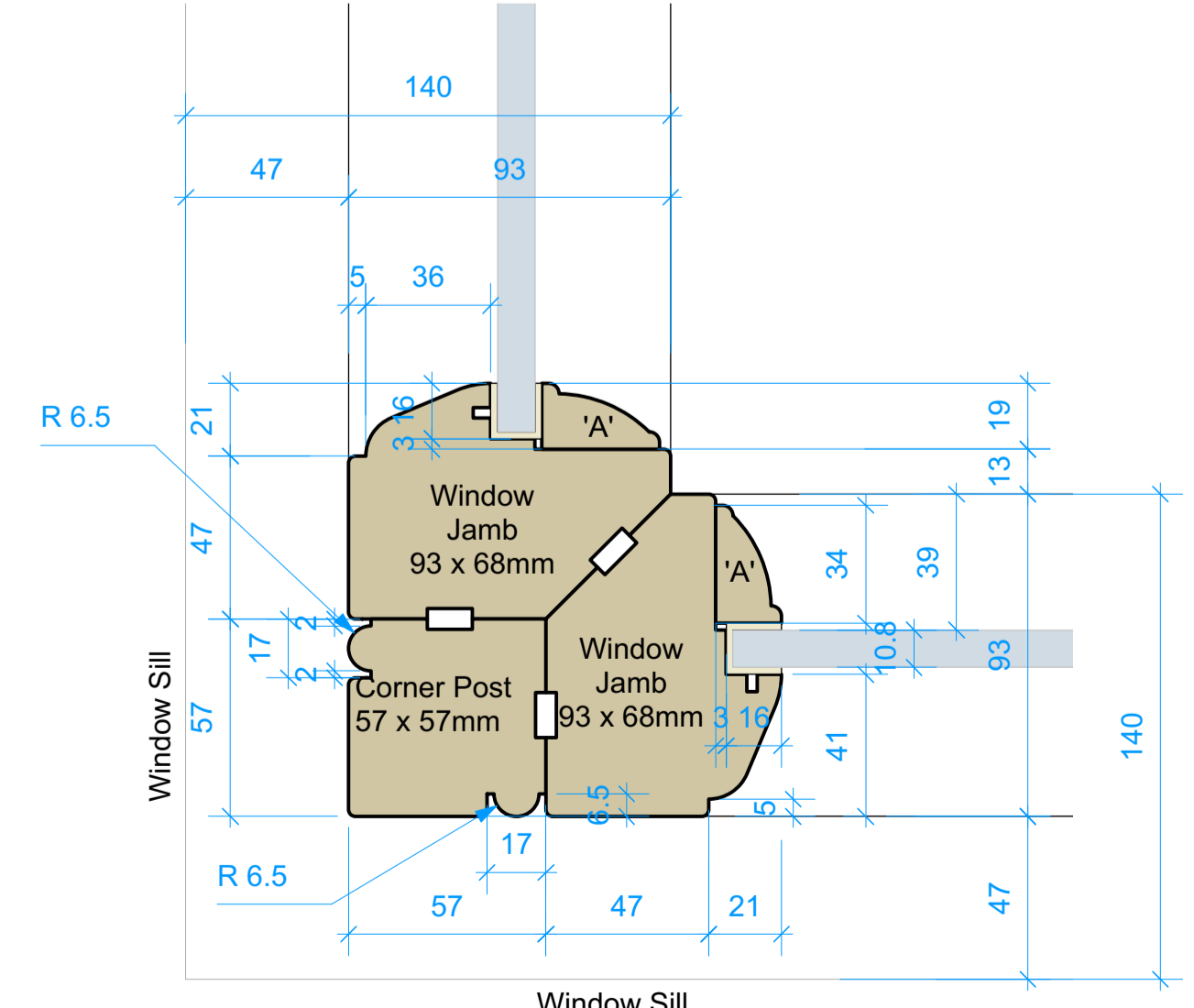

'RHS' WINDOW JAMB TO OUTER CORNER POST - PLAN VIEW

- 1) This drawing is the copyrighted and may not be altered or reproduced in any way without written permission
- 2) Written dimensions supersede manual or electronically scaled dimensions. All dimensions must be checked on site by Contractor before commencement of the works or fabrication
- 3) This drawing is to be used only for the purposes intended as described in the Drawing Title box
- 4) This drawing must be read in conjunction with all other Consultants drawings & specifications applicable to this project
- 5) The information contained herein is confidential and may not be copied or disclosed to any other person or used for any purpose other than that for which it was originally prepared and supplied without the prior written consent

CONSTRUCTION DESIGN & MANAGEMENT REGULATIONS 2015
DESIGNERS HAZARD INFORMATION FOR CONSTRUCTION

The notes below refer specifically to the information shown on this drawing. Refer to the Construction Phase Health and Safety Plan for further information.

1) If you do not fully understand the risks involved during the construction of the items indicated on this drawing ask your Manager, Health & Safety Advisor or a member of the Design Team before proceeding.

GLAZING

10.8mm laminated safety glass

GLAZING PUTTY

Hodgson Heritage Putty

2mm thick back bedding

2mm edge clearance

16mm rebate upstand

ENTRANCE DOOR

Inward opening

Hung on three pairs of Polished Brass Butt Hinges

5 Lever Dead Lock Polished Brass BS3621 Rated - CE / UKCA Marked

Roller bolt mortice catch Polished Brass

Bolt through Ornate Guardsman Pull Handle in Polished Brass

Traditional Victorian Polished Brass Letter Plate

Timber Type: Sapele Hardwood

Final locking mechanism to be agreed with Client
Painter to ordering

WINDOW & DOOR FRAME

Timber Type: Sapele Hardwood

WOOD FINISH

Pure Linseed Oil Paint

Solvent free linseed oil paint for woodwork

All timber sanded with 120 grit

Treat all Knots with Shellac Knotting Primer

Prime wood with one coat of Primer

Windows & Door Frames - Finish with three coats of 002. Cod White (ingilby.co.uk)

Entrance Door Leaf - Finish with three coats of BLACKOUT (38) (linseedpaint.com)

NOTE:
Refer to <https://www.ingilby.co.uk/> and <https://linseedpaint.com/> for full preparation and application directions.

PLANNING ISSUE



03300 240365 www.ermc.co.uk info@ermc.co.uk

Client OSBORNES

Project Title Shopfront alterations
Osbornes
29 High St, Ryde PO33 2HT

Drawing Title / Description JOINERY DETAILS

Our Project Ref. 2840	Scale 1:2 @ A1	Date 26/02/24	Drawn TH	Checked
-----------------------	----------------	---------------	----------	---------

Client Project Ref. 2840	Originator ERM	Zone 00	Type DR	Level A	Revision 4005
--------------------------	----------------	---------	---------	---------	---------------

This drawing has a Copyright. Permission to use is required