

V3 Drawing Register

Sheet Number	Sheet Name	Rev	Revision Date
1045-300	Cover Page & Design Risk Register	A	Feb 2024
1045-310	Foundation & Sub-Floor Plans	A	Feb 2024
1045-320	Floor Plans	A	Feb 2024
1045-330	MEP Plans	A	Feb 2024
1045-340	Elevations	A	Feb 2024
1045-350	Sections	A	Feb 2024

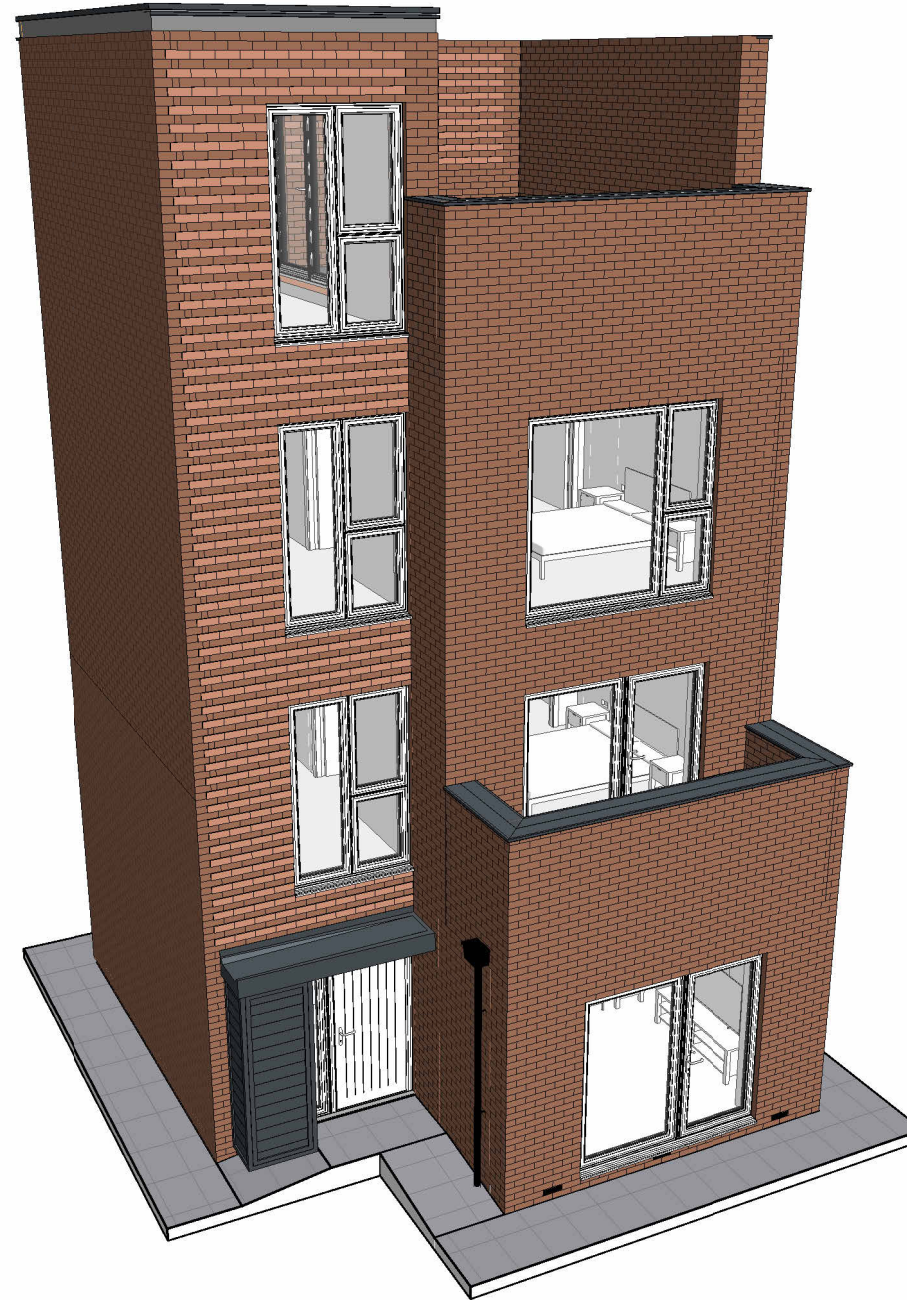

Rev	Description	Date
A	General updates as detailed within issue email dated 02.02.2024	Feb 2024
-	Construction Issue	July 2023

NORTHSTONE

Peel L&P
Salford
M50 2TG

CONSTRUCTION

PROJECT

Gen2 House Type Portfolio

DRAWING NAME

**1045-V3-X (As)
Cover Page & Design Risk Register**

DRAWING NUMBER	DESIGNATION	DRAWN BY
1045-300	X	Design
DATE	SCALE (@ A3)	REV
June 2023		A

Notes:

- All dimensions to structure unless otherwise stated.
- Drawing to be read in conjunction with Northstone specification & all other project related design information and drawings.
- Any discrepancies to be reported to Northstone Technical prior to commencement of works.
- All materials and workmanship to be in accordance with current NHBC Technical Standards and Building Regulations.

DO NOT SCALE FROM THIS DRAWING. ALWAYS PRINT IN COLOUR.

Design Risk Register

Element	Comments
Lifting Operations	To avoid injury when handling heavy components, specialist handling equipment is to be utilised for the positioning of heavy objects/materials. Large glazing to be installed with specialist lifting equipment by trained personnel. Protection barriers to be provided to prevent mechanical damage following installation.
Craneage	Crane supplier to be satisfied of adequate support to outriggers, correct lifting positions to be established to avoid slippage of sheet materials during lifting and placement. Sub-contractors and suppliers to 'design in' lifting eyes and identify weights of heavy items at drawing approval stage. All RAMS to be obtained and approved prior to any lifting operations being carried out.
Ground Floor Construction	Mechanical Lifting equipment to be utilised to position pre-cast concrete floor planks. Manual handling assessment to be carried out.
Working at Height	Install temporary scaffolding barrier to exposed edges of upper floors including toe boards throughout the build period. Provide scaffolding to all areas requiring placement of materials and finishing to all areas above ground level. Scaffolding to be positioned to avoid the need to overreach causing strain injury when placing materials. Protect areas below high level working from falling debris. Ensure space required for crane is achievable and suitable hard standing is provided. Ensure maximum fall height when fixing trusses into position is 2 metres by utilising appropriate safety measures and equipment.
Stairs	To prevent falls provide temporary guarding and edge protection to open well areas and keep clear during construction, eliminating the possibility of trip hazards. Stairs to be erected as early as possible during the construction process to provide vertical circulation and means of escape in case of fire.
Masonry Construction	When working at height mechanical lifting measures required to lift brick and block packs into position to reduce manual handling.
Lintels	Manual Handling Assessments to be carried out for all lintels, light craneage to be utilised for lintels considered too heavy for manual handling.
Structural Steelwork	Mechanical lifting measures required to reduce manual handling. Ensure required space for crane is achievable and suitable hard standing is provided.
Windows / Structural Openings	Any structural apertures below 800mm to be fitted with temporary guarding to prevent falls. Any structural apertures below 800mm and extending to floor level to be fitted with temporary guarding and edge protection to prevent falls. Mechanical lifting measures and frame and glazing fitted separately to be considered for installation of large windows and combination door & window frames. Window manufacturer to be consulted regarding best means of installation.
Window Cleaning & Maintenance	'Easy Clean' hinges are not an option due to the top hung design to a majority of the windows, as such windows should be cleaned from ground level using a telescopic 'reach & wash' system. All windows used to be Aluminium or UPVC frames to eliminate the need for future decoration.
Roof Construction	Ensure space required for crane is achievable and suitable hard standing is provided. Ensure maximum fall height when fixing trusses into position is 2 metres by utilising appropriate safety measures and equipment.

1045-V3-X (As)

FOUNDATION & SUB-FLOOR LEGEND

Brick Face External Wall

OUTSIDE - 102.5mm clay facing brickwork as site specific materials plan
 - 125mm clear cavity
 - 100mm block as specification

INSIDE - 100mm concrete block as engineers details

100mm Sleeper Wall

- 100mm concrete block as engineers details

215mm Sleeper Wall

- 100mm concrete block as engineers details
 - 15mm cavity fully filled with mortar
 - 100mm concrete block as engineers details

Trench Block

- 350mm concrete trench block as engineers details

Services & Ventilation

SVP 110mm Soil and Vent Pipe
 RWP Rainwater pipe as specification
 GULLY Sealed floor gully for level access shower
 Water Water Entry Point
 Data Lead In Data Entry Point
 E Electric Entry Point
 G Gas Entry Point
 Sub-Floor Telescopic Vent

Floor Finish & Span

Extent of Floor Screen
 Span of Ground Floor Construction

NOTES

1. Refer to engineers details and specification for all block strengths.
2. Key to be read in conjunction with construction specification.
3. Expansion and movement joints, bed reinforcement and wind posts to engineers details.
4. Always refer to site investigation report and engineers details for any gas membrane requirements.

Sub-Floor Void Ventilation Schedule				
Building Area (m ²)	Building Perimeter (m)	Ventilation Required	Minimum Number of Vents Required	Number of Vents Provided
40.01 m ²	26.65	39970 mm ²	8	8
* Based on 500mm ² /m ² of Floor Area				

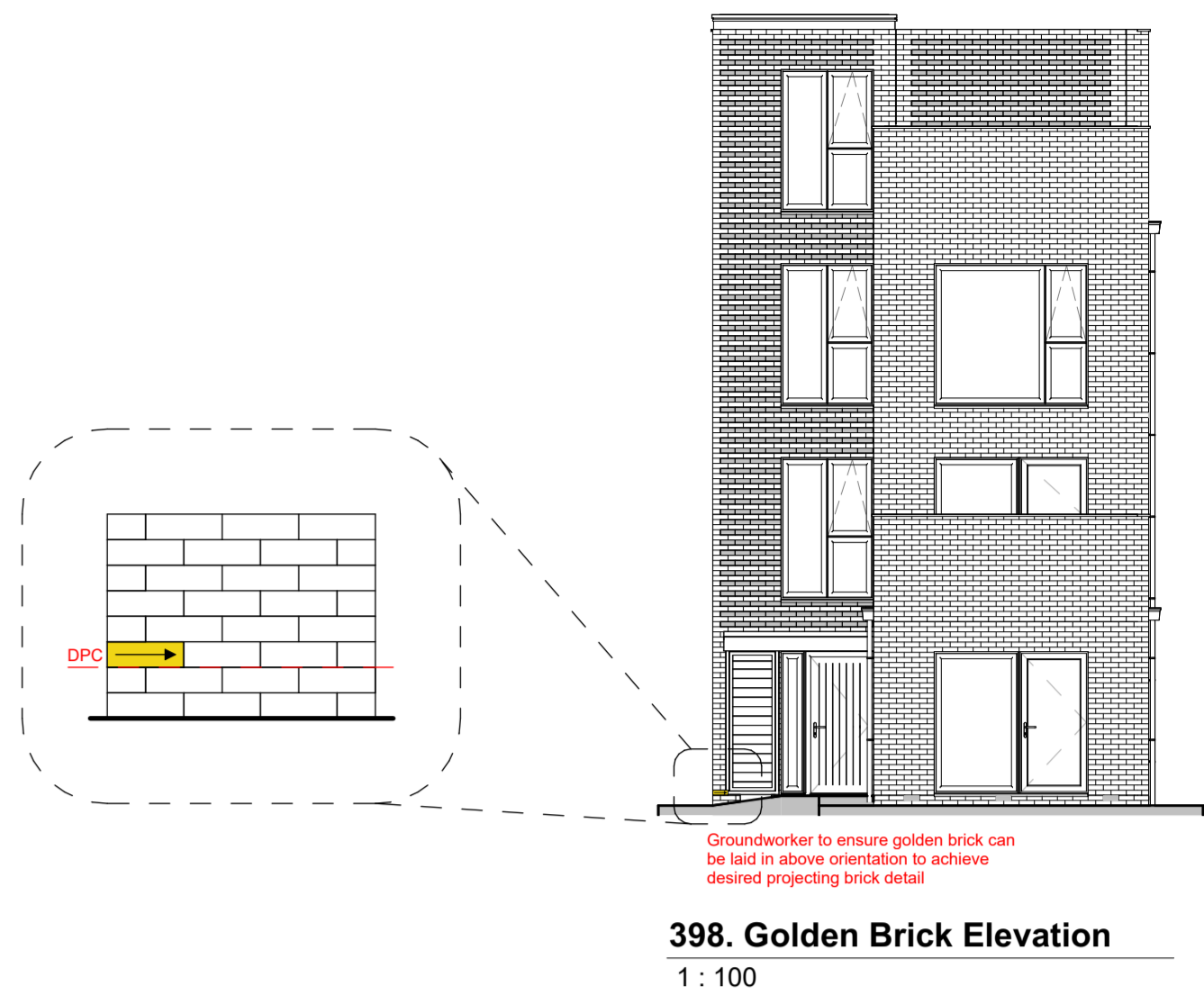
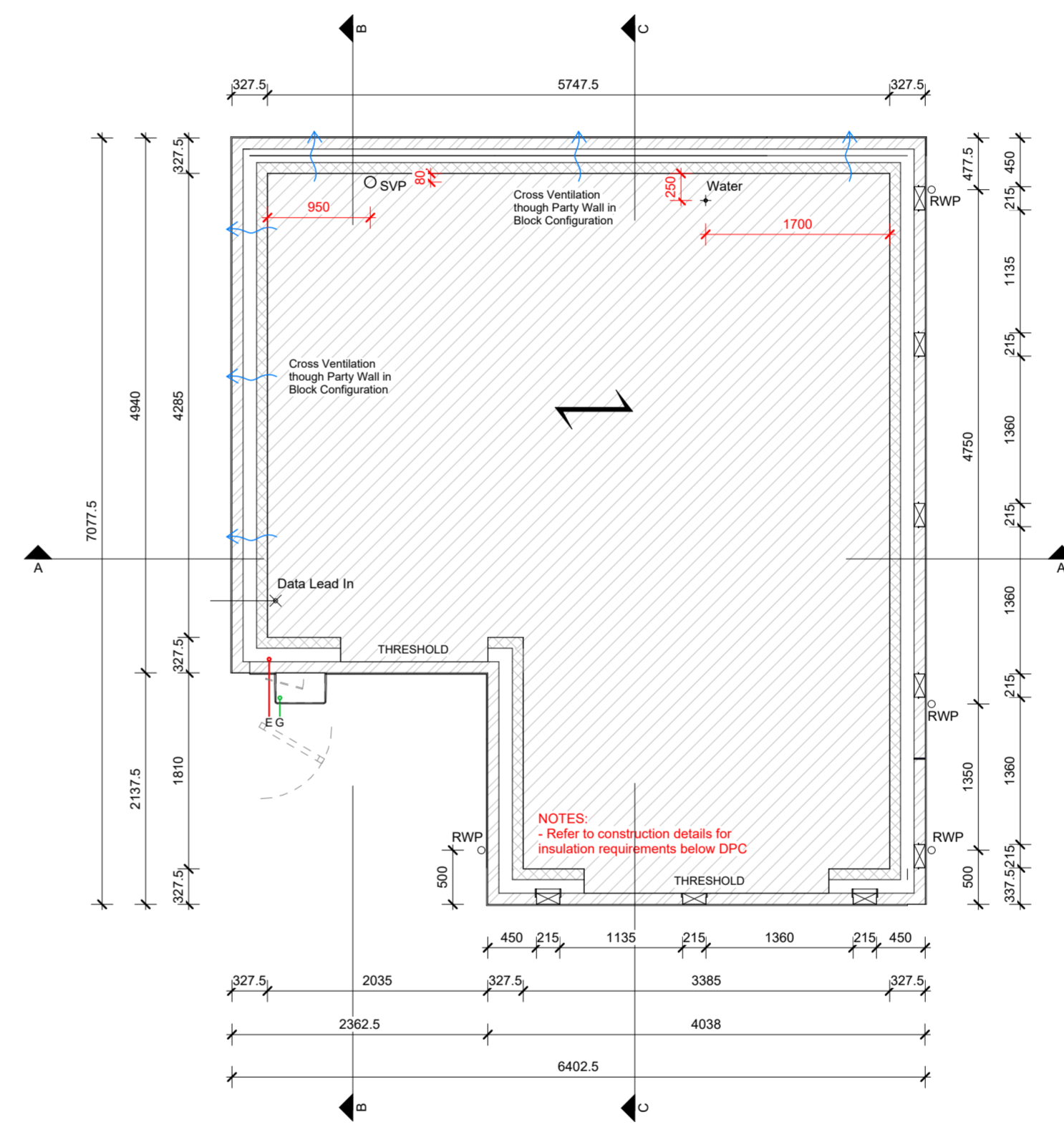
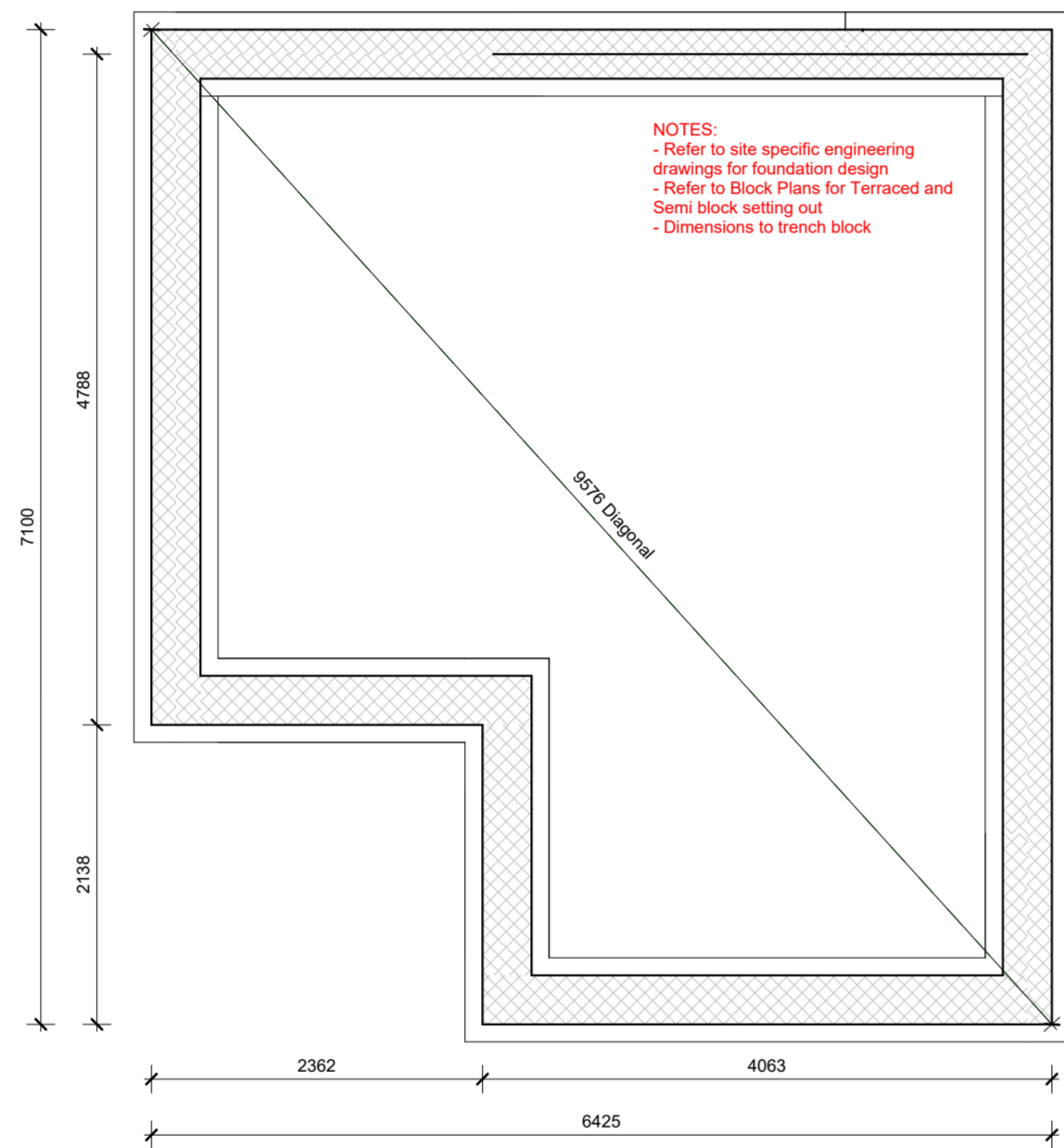

General updates as detailed within issue email dated 02.02.2024	Feb 2024
Construction Issue	July 2023

Rev	Description	Date

NORTHSTONE
Peel L&P
Salford
M50 2TG

CONSTRUCTION

PROJECT
Gen2 House Type Portfolio

DRAWING NAME
**1045-V3-X (As)
Foundation & Sub-Floor Plans**

DRAWING NUMBER 1045-310	DESIGNATION X	DRAWN BY Design
DATE June 2023	SCALE (@ A1) As indicated	REV A

Notes:

- All dimensions to structure unless otherwise stated.
- Drawing to be read in conjunction with Northstone specification and all other project related design information and drawings.
- Any discrepancies to be reported to Northstone Technical prior to commencement of works.
- All materials and workmanship to be in accordance with current NHBC Technical Standards and Building Regulations.

DO NOT SCALE FROM THIS DRAWING. ALWAYS PRINT IN COLOUR.

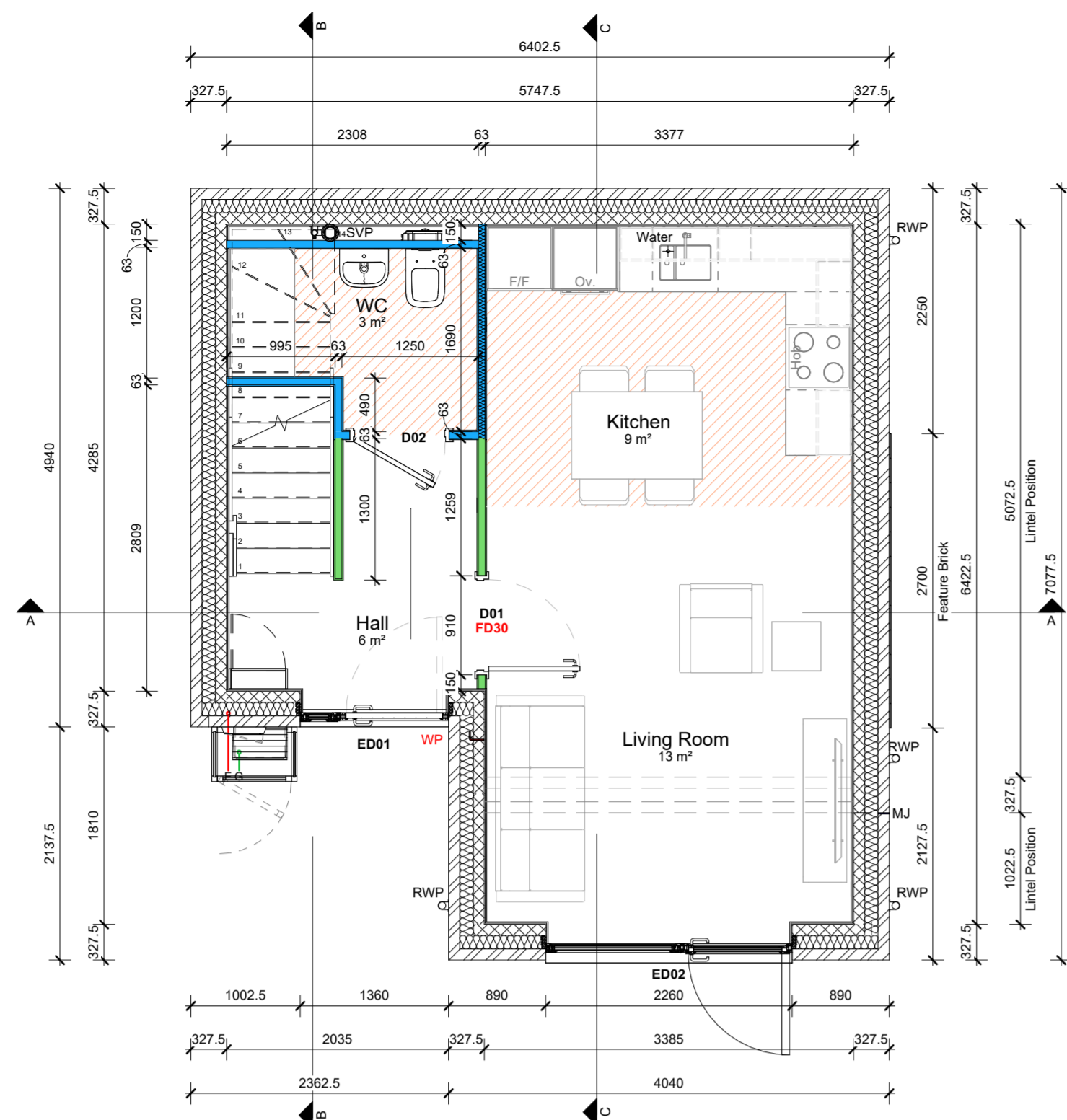

320. Ground Floor Setting Out

1 : 50

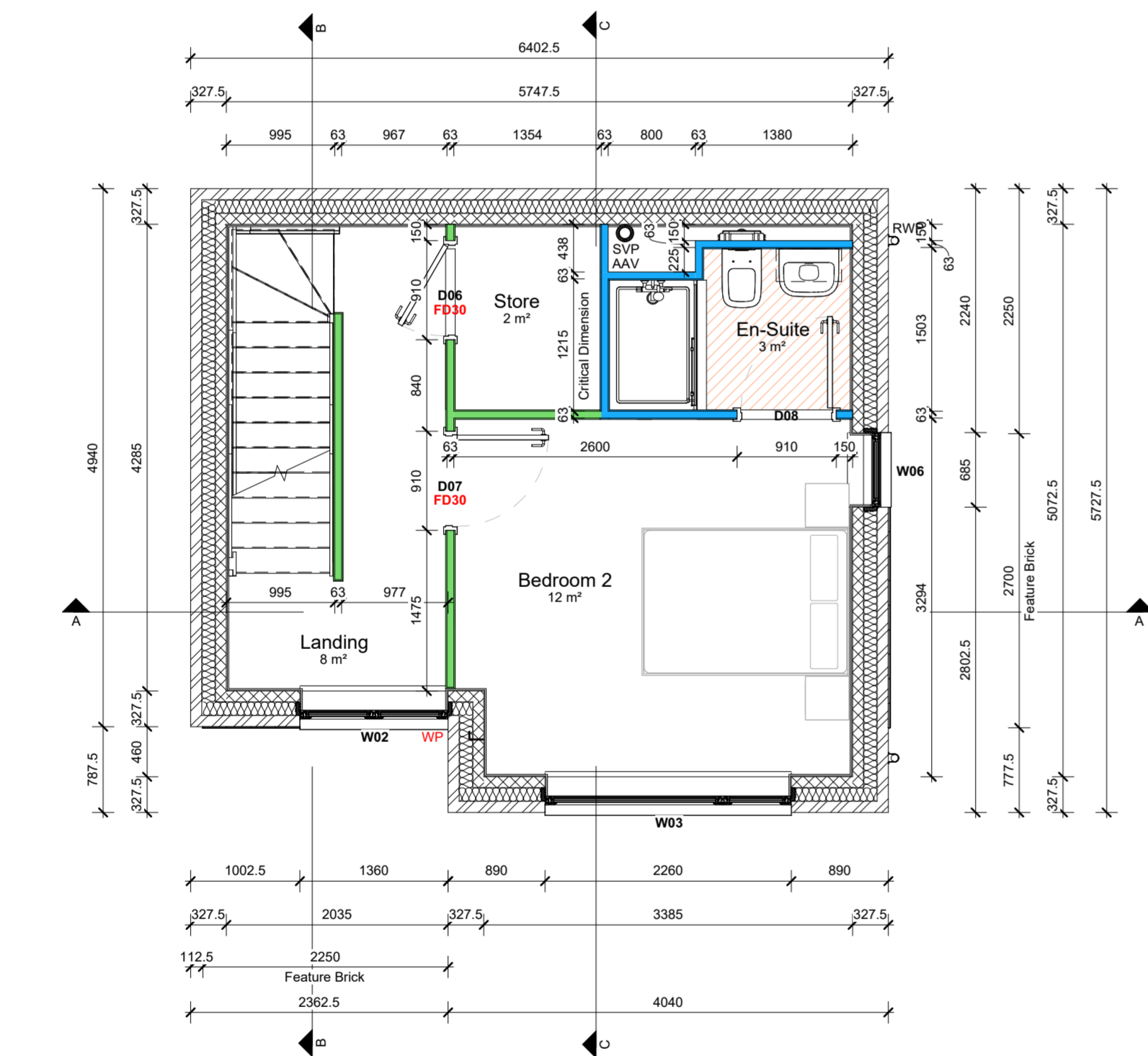

340. Second Floor Setting Out

1 : 50

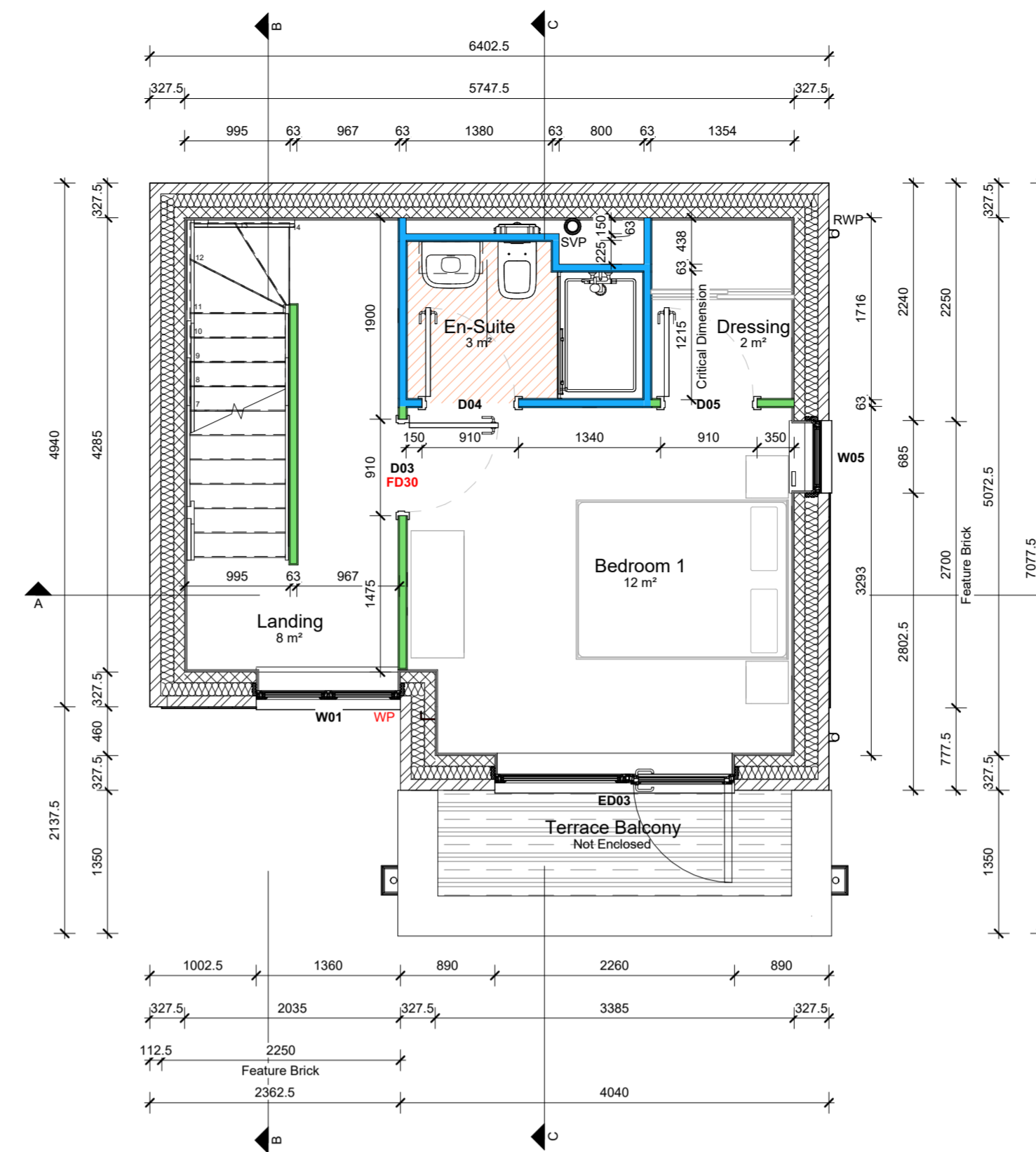

330. First Floor Setting Out

1 : 50

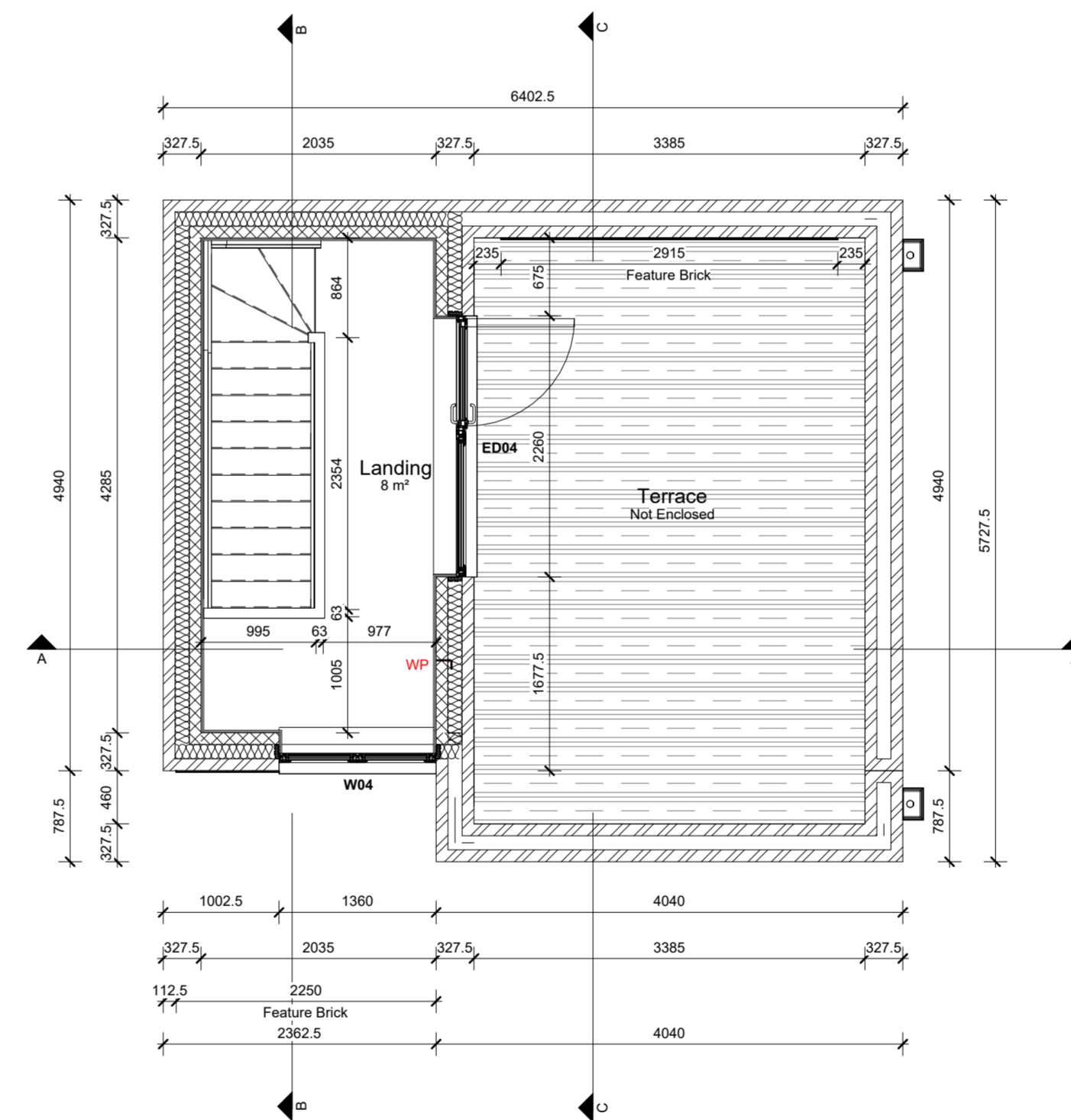

350. Third Floor Setting Out

1 : 50

WALL TYPE LEGEND

Brick Face External Wall

- OUTSIDE
 - 102.5mm clay facing brickwork to site specific materials plan
 - 125mm cavity fully filled with insulation as specification
 - 100mm block as specification
- INSIDE
 - 12.5mm plasterboard on 10mm adhesive slabs, all joints taped and filled before wet plaster skim finish

NON LOADBEARING STUD PARTITIONS

General Partition

- 63x38mm C16 studwork at max 600mm centres with suitable noggins
- Patts between stud with 12mm Ply where required for MEP fixtures and fittings
- 1no. layer of 12.5mm plasterboard mechanically fixed to stud both sides of wall with all joints taped and filled before wet plaster skim finish

Pattressed Partition Wall

- 63x38mm C16 studwork at max 600mm centres with suitable noggins
- 12mm ply mechanically fixed to stud on load-bearing side of wall, (Kitchens etc.)
- 1no. layer of 12.5mm plasterboard mechanically fixed to stud both sides of wall with all joints taped and filled before wet plaster skim finish

Acoustic & Fire Rated Partition

- 30 Min
- 63x38mm C16 studwork at max 600mm centres with suitable noggins
- Voids between studwork fully filled with 60mm Rockwool Flexi or similar approved mineral wool.
- Patts between stud with 12mm Ply where required for MEP fixtures and fittings
- 1no. layer of 12.5mm plasterboard mechanically fixed to stud both sides of wall with all joints taped and filled before wet plaster skim finish
- Achieves F_L40dB in accordance with AD-E
- Achieves REI 30 fire resistance in accordance with British Gypsum White Book

Wet-Room Partition (WC / Bathroom / En-suite)

- 63x38mm C16 studwork at max 400mm centres with suitable noggins
- Patts between stud with 12mm Ply where required for MEP fixtures and fittings
- 12.5mm moisture resistant plasterboard mechanically fixed to stud on wet-room side of wall with all joints taped and filled prepared for tiling or wet plaster skim finish
- 12.5mm standard plasterboard mechanically fixed to stud on dry-room side of wall where required with all joints taped and filled before wet plaster skim finish

Framing Wall

- 63x38mm C16 studwork wide face out at max 400mm centres with suitable noggins
- 1no. layer of 12.5mm plasterboard mechanically fixed to stud on room side of wall with all joints taped and filled before wet plaster skim finish

Anchored/Buttress Stud Partition

- Refer to structural engineers details and Northstone construction details. Buttress Studs and Windposts not required on party walls.

Insulation Between Studs

- Voids between studwork fully filled with 60mm Rockwool Flexi or similar approved mineral wool where indicated on drawing for AD-E compliance
- Achieves F_L40dB in accordance with AD-E
- Achieves REI 30 fire resistance in accordance with British Gypsum White Book

NOTES

- Refer to engineers details and specification for all block strengths.
- Key to be read in conjunction with construction specification.
- Expansion and movement joints, bed reinforcement and wind posts to engineers details.
- All dimensions are to structure unless otherwise noted.

FLOORING LEGEND

LVT Flooring

- Vinyl flooring applied as Northstone finishes specification and relevant customer options.

External Door Schedule

Floor	Door Ref	Width	Height	Door Width	Reveal Depth	U-Value (Door / Sidelight)	Toughened Glass	Glazing Specification	MF Width	Sidelight MF Width	MF Height	Area of Glazing	Notes
Ground Floor FFL/DPC	ED01	1360	2110	1000	50	0.45Wm ² /K / 0.55Wm ² /K	Yes	Triple Glazed	984	344	2061	0.451 m ²	
Ground Floor FFL/DPC	ED02	2260	2110	1000	70	0.90Wm ² /K / 0.55Wm ² /K	Yes	Triple Glazed	984	1244	2061	3.508 m ²	Trickle Vent in Sidelight
First Floor FFL	ED03	1960	1960	1000	70	0.90Wm ² /K / 0.55Wm ² /K	Yes	Triple Glazed	984	1244	1911	3.233 m ²	Trickle Vent in Sidelight
Third Floor FFL	ED04	2260	1960	1000	70	0.90Wm ² /K / 0.55Wm ² /K	Yes	Triple Glazed	984	1244	1911	3.233 m ²	

V3 Window Schedule

Floor	Window Ref	Width	Height	Toughened Glass	U-Value	Reveal Depth	Obscure Glazing	Escape Window	Trickle Vents	Glazing Specification	Area of Glazing	Notes
First Floor FFL	W01	1360	2110	Yes	0.55Wm ² /K	70	No	Yes	Yes	Triple Glazed	2.096 m ²	
First Floor FFL	W05	665	2110	Yes	0.55Wm ² /K	70	No	Yes	Yes	Triple Glazed	1.021 m ²	
Second Floor FFL	W03	2260	2110	Yes	0.55Wm ² /K	70	No	Yes	Yes	Triple Glazed	3.882 m ²	
Second Floor FFL	W02	1360	2110	Yes	0.55Wm ² /K	70	No	Yes	Yes	Triple Glazed	2.096 m ²	
Second Floor FFL	W06	665	2110	Yes	0.55Wm ² /K	70	No	Yes	Yes	Triple Glazed	1.021 m ²	
Third Floor FFL	W04	1360	2110	Yes	0.55Wm ² /K	70	No	No	Yes	Triple Glazed	2.096 m ²	

Internal Door Schedule

Floor	Door Ref	From Room	To Room	Structural Width	Structural Height	Leaf Width	Casing Depth	Fire Rating	Self Closer	Notes
Ground Floor FFL/DPC	D01	Living Room	Hall	910	2326	838	96	FD30	No	
Ground Floor FFL/DPC	D02	Hall	WC	910	2326	838	96	Not Fire Rated	No	
First Floor FFL	D03	Bedroom 1	Landing	910	2017	838	96	FD30	No	
First Floor FFL	D04	En-Suite	Bedroom 1	910	2017	838	96	Not Fire Rated	No	
First Floor FFL	D05	Dressing	Bedroom 1	910	2017	838	96	Not Fire Rated	No	
Second Floor FFL	D06	Landing	Store	910	2017	838	96	FD30	No	
Second Floor FFL	D07	Bedroom 2	Landing	910	2017	838	96	FD30	No	
Second Floor FFL	D08	En-Suite	Bedroom 2	910	2017	838	96	Not Fire Rated	No	

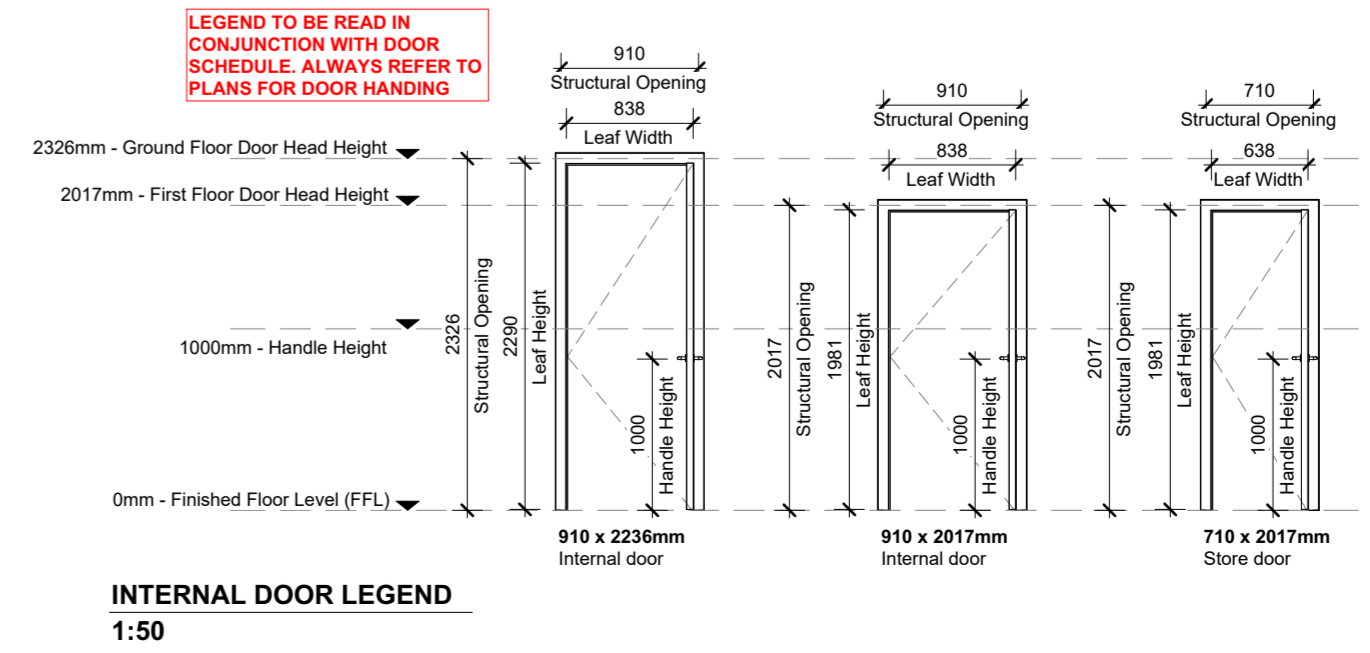
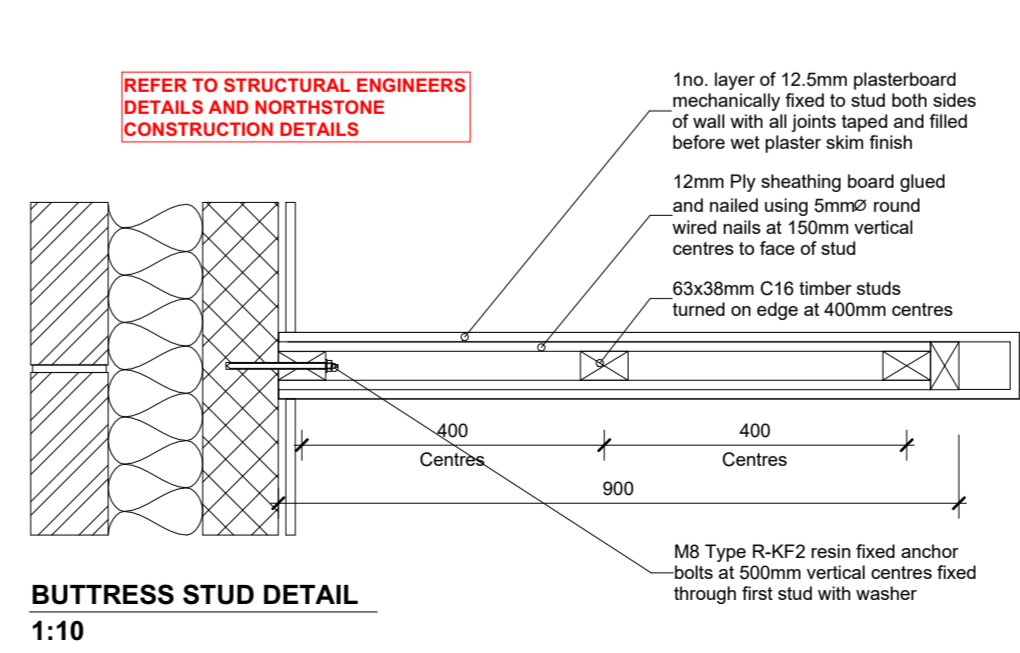

General updates as detailed within issue email dated Feb 2024
02.02.2024
Construction Issue July 2023

Rev	Description	Date
1	Construction Issue	July 2023

NORTHSTONE

PROJECT
Gen2 House Type Portfolio

DRAWING NAME
1045-V3-X (As) Floor Plans

DRAWING NUMBER	DESIGNATION	DRAWN BY
1045-320	X	Design

DATE	SCALE	REV
June 2023	(@ A1)	A

Notes:

- All dimensions to structure unless otherwise stated.
- Drawing to be read in conjunction with Northstone specification & all other project related design information and drawings.
- Any discrepancies to be reported to Northstone Technical prior to commencement of works.
- All materials and workmanship to be in accordance with current NHBC Technical Standards and Building Regulations.

DO NOT SCALE FROM THIS DRAWING. ALWAYS PRINT IN COLOUR.

Electrical Fixture Schedule	
Electrical Item	Quantity
External Wall Light	2
External Wall Light	2
Recessed spot light	1
Hall	
13A Switched Fused Spur	1
Consumer Unit M&E - Refer to Detail	1
Double Socket	1
Recessed spot light	3
Single gang light switch - single way	1
Smoke Detector	1
Triple gang light switch - two way	1
Wondwall thermostat	1
WC	
Ceiling mounted fan CV2-GIP	2
Double Socket	1
Kitchen gang plate with appliance names	1
Recessed spot light	2
Kitchen	
13A Unswitched Fused Spur	3
Ceiling mounted fan CV2-GIP	1
Cooker Control Box	1
Double Socket	2
Double Socket with USB	2
Heat Detector	1
Kitchen gang plate with appliance names	1
Pendant light	1
Recessed spot light	4
Living Room	
2-Way Data Module with CAT6 & TV Inserts	1
13A Switched Fused Spur	1
Double gang light switch - two way	2
Double Socket	5
Internal Wall Light	4
Wondwall switch	1
Landing	
Double Socket	2
Pendant light	1
Smoke Detector	1
Triple gang light switch - two way	1
Wondwall thermostat	1
Bedroom 1	
2-Way Data Module with CAT6 & TV Inserts	1
13A Switched Fused Spur	1
Double gang light switch - two way	1
Double Socket	2
Double Socket with USB	3
Pendant light	2
Recessed spot light	3
Single gang light switch - single way	3
Single gang light switch - two way	2
En-Suite	
Ceiling mounted fan CV2-GIP	1
Recessed spot light	3
Dressing	
Double Socket	1
Recessed spot light	2
Landing	
Pendant light	2
Single gang light switch - single way	1
Smoke Detector	1
Triple gang light switch - two way	1
Wondwall thermostat	1
Store	
Internal Wall Light	1
Bedroom 2	
13A Switched Fused Spur	1
Double Socket	3
Double Socket with USB	1
Pendant light	1
Single gang light switch - single way	2
En-Suite	
Ceiling mounted fan CV2-GIP	1
Recessed spot light	3
Landing	
Pendant light	1
Smoke Detector	1
Triple gang light switch - two way	1

Ventilation Fixture Schedule	
Ventilation Item	Quantity
Single air brick for CV2-GIP fan	4

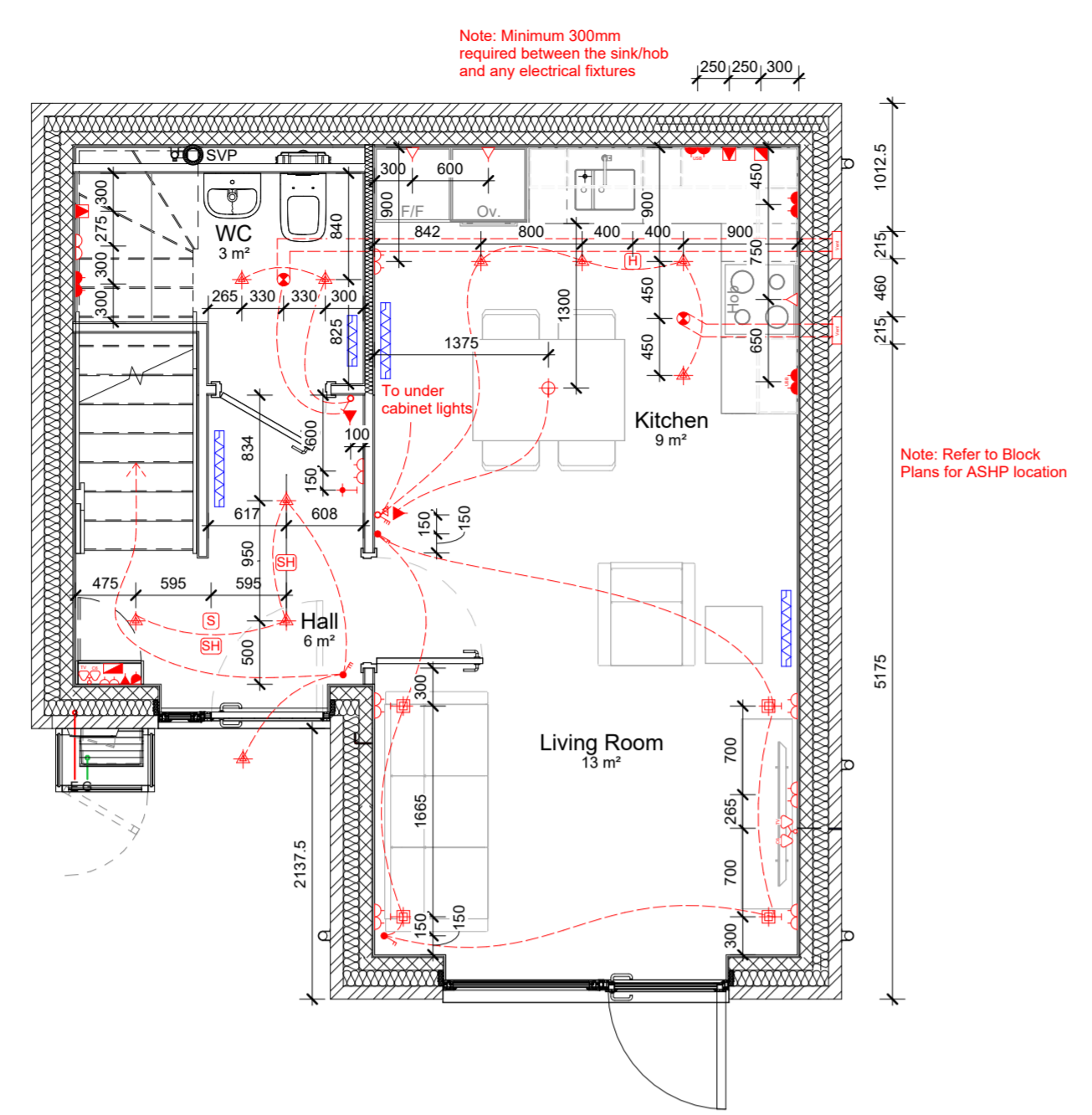

325. Ground Floor MEP
1 : 50

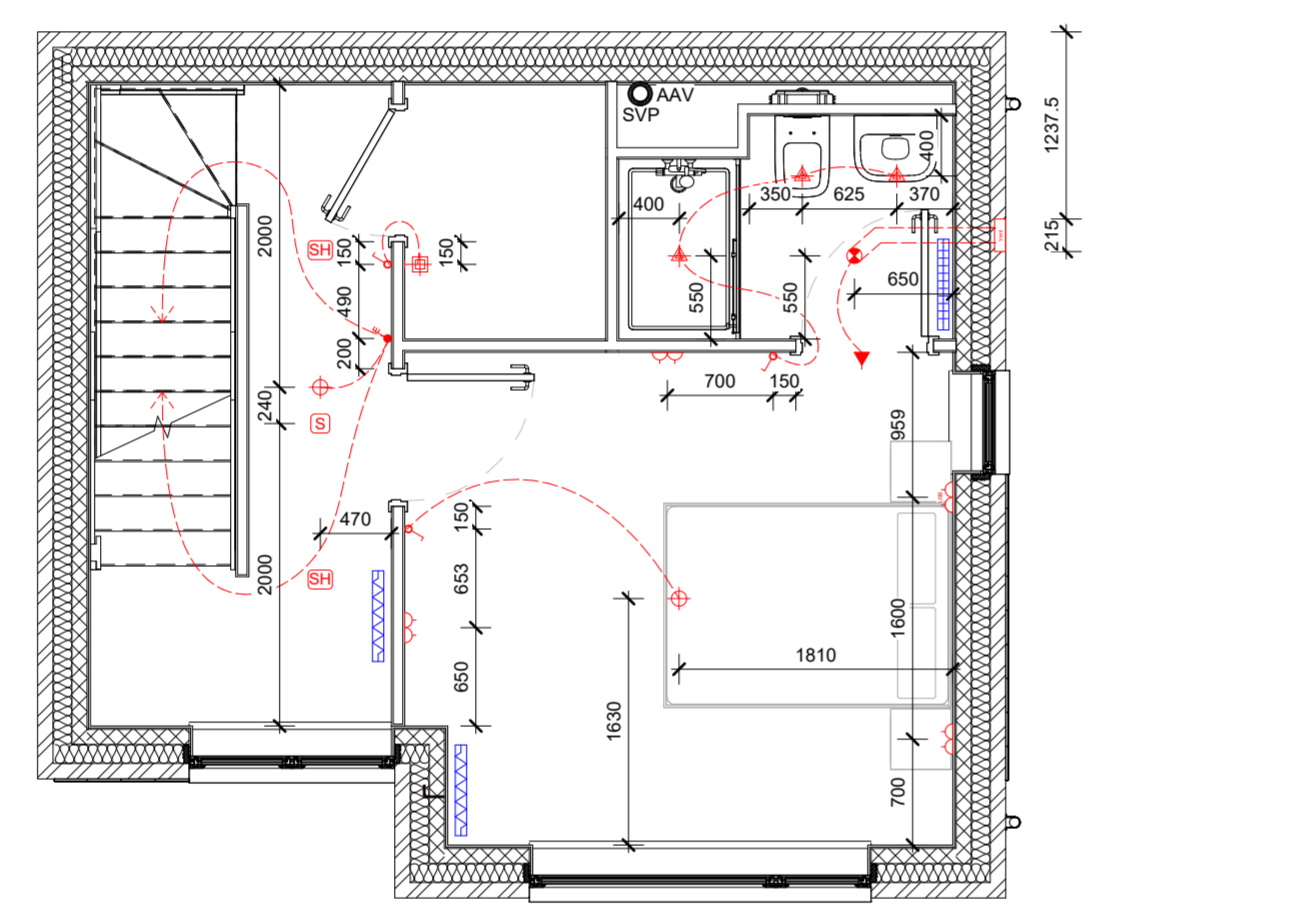

345. Second Floor MEP
1 : 50

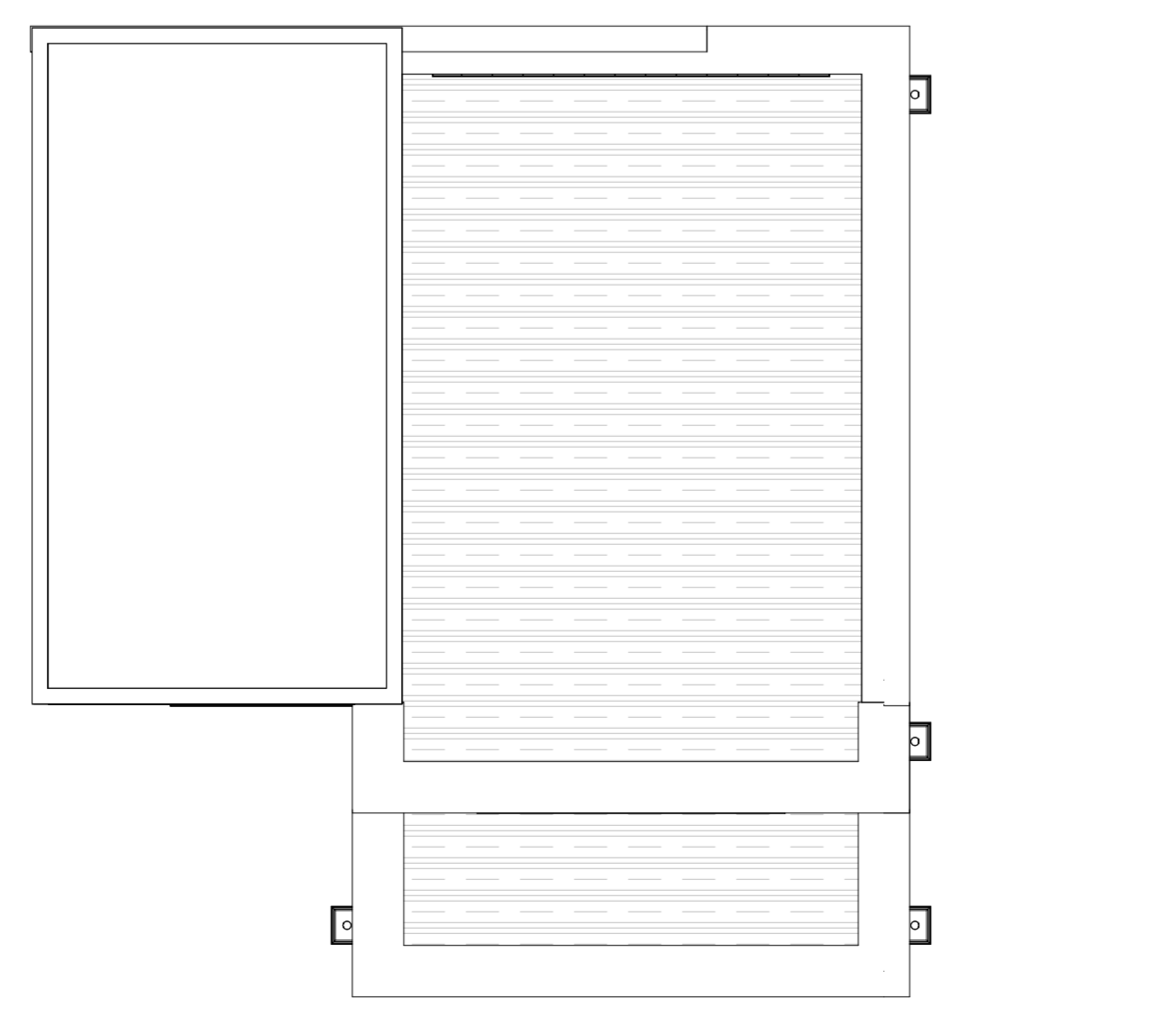

359. Roof Plan
1 : 50

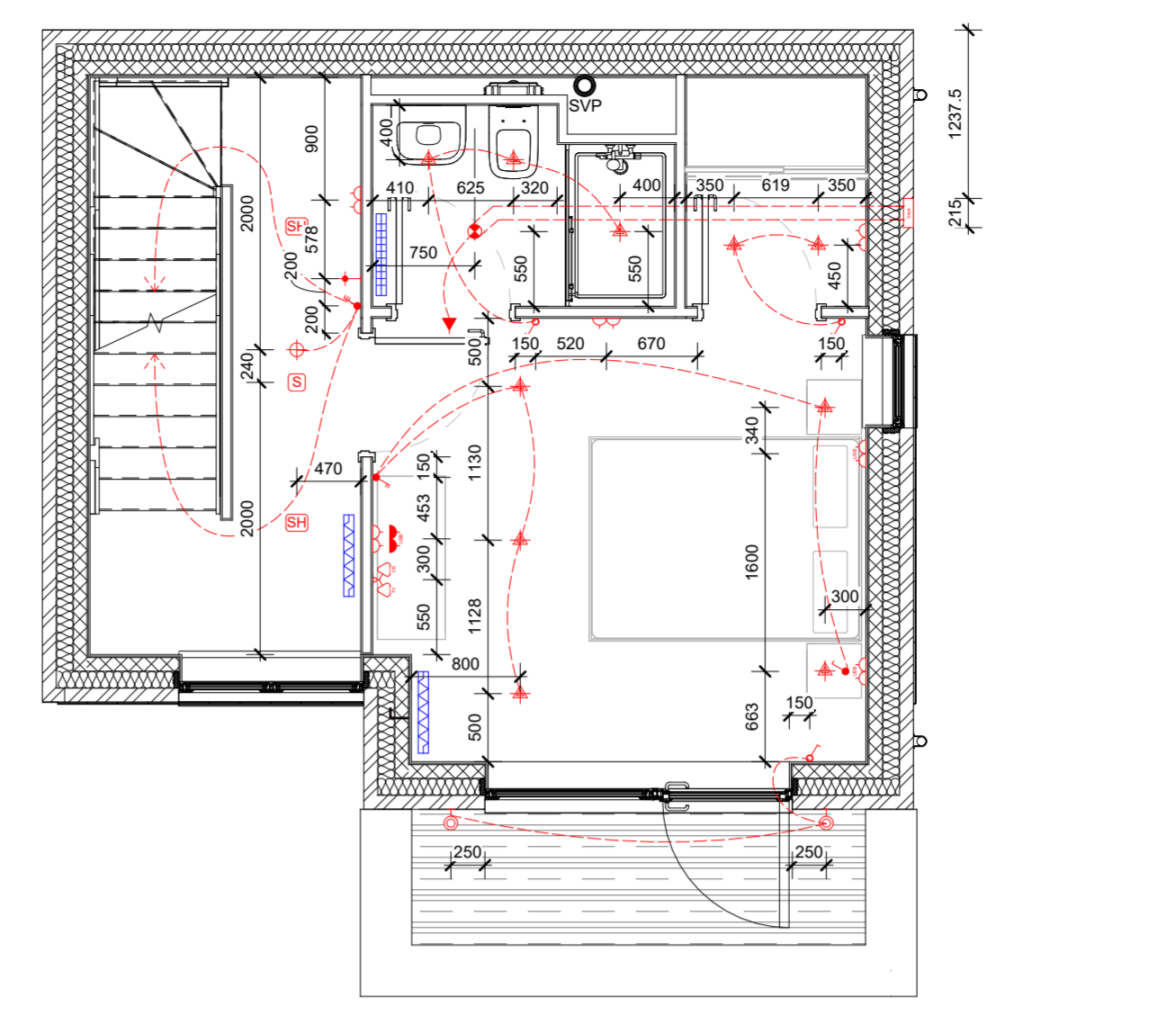

335. First Floor MEP
1 : 50

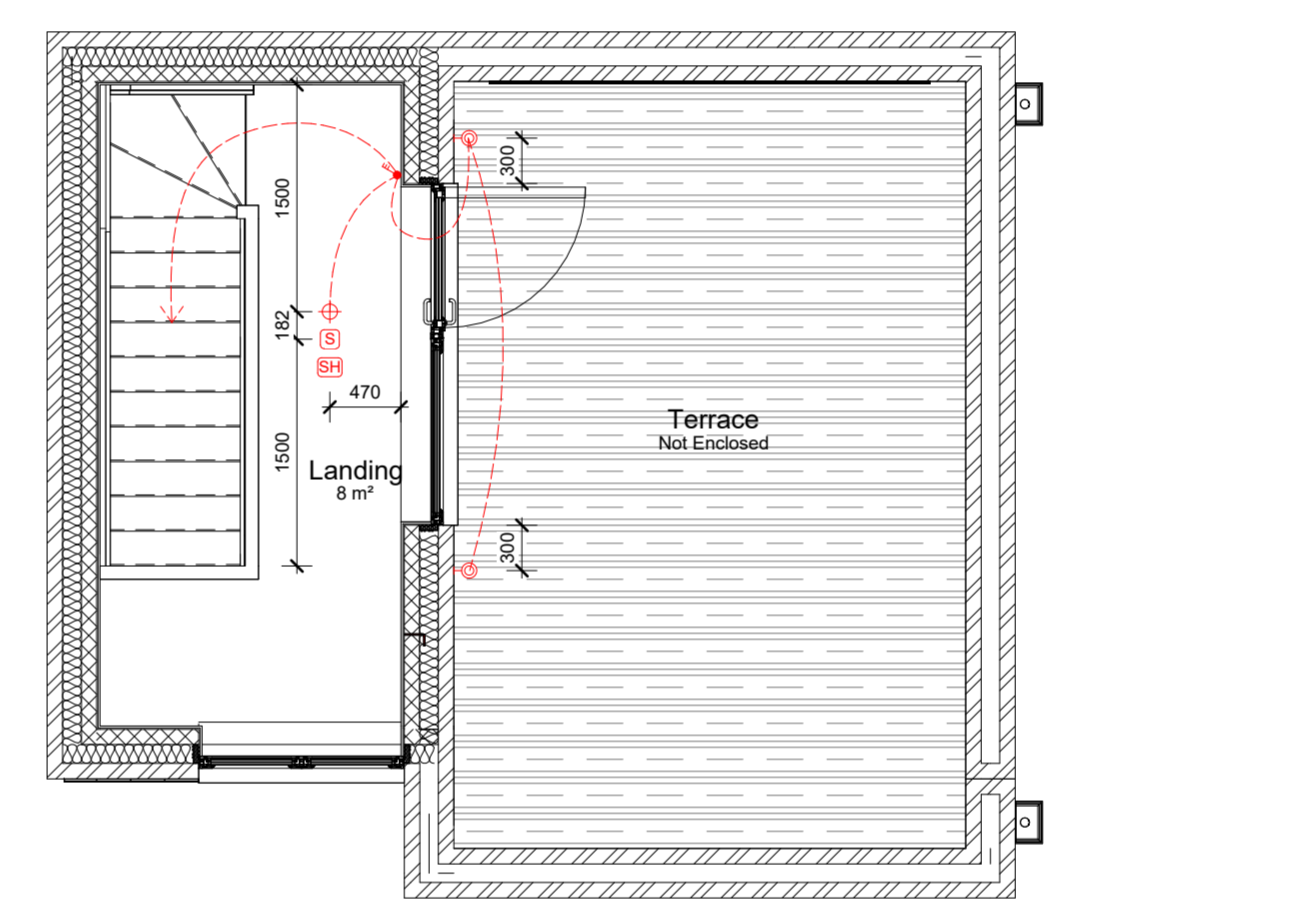

355. Third Floor MEP
1 : 50

M&E LEGEND

LIGHTING

- External Wall Light
- Internal Wall Light
- Pendant Light
- Recessed Spot Light
- Bulkhead Light

SWITCHES

- Single Gang Switch
- Double Gang Switch
- Triple Gang Switch
- Single Two-Way Switch
- Double Two-Way Switch
- Triple Two-Way Switch
- Wondwall Switch
- 13A Switched Fused Spur
- 13A Unswitched Fused Spur
- Kitchen Gang Plate
- Cooker Control Box

SOCKETS

- Single Socket - Low Level
- Unswitched Single Socket - Low Level
- 5 Amp Socket
- Double Socket - Low Level
- Double Socket - Low Level With USB
- Single Socket - Worktop Level
- Double Socket - Worktop Level
- Double Socket - Worktop Level With USB
- External IP65 Rated Socket
- Shaver Socket

MISC. ELECTRICAL

- Consumer Unit
- Central Heating Room Thermostat
- Data Module with TV Point Insert
- Data Module with CAT6 Socket Insert
- Door Bell Sounder
- Door Bell Push

FIRE & GAS PROTECTION

- Heat Detector
- Carbon Monoxide Detector
- Smoke Detector
- Sprinkler Head

VENTILATION

- Ceiling Mounted Fan
- Brick Vent - Plan
- Brick Vent - Elevation
- Tile Vent

HEATING & PLUMBING

- Central Heating Boiler
- Gas Point
- Radiator
- Towel Rail
- Boiler Flue Terminal
- External Tap

Note: All plumbing and ventilation items shown indicatively. Refer to independent third party designs for exact details of heating and ventilation designs.

IMPORTANT
THIS LEGEND MUST ALWAYS BE PRINTED WITH ANY MEP PLAN EXTRACTS
ANY CLASHES OR DISCREPANCIES MUST BE REPORTED TO NORTHSTONE TECHNICAL TEAM

AIR SOURCE HEAT PUMP LEGEND

CLEARANCE

ELEVATIONS

ANCILLARY EQUIPMENT

- IP67 Rated Rotary Pole Isolator Switch
- IP66 Rated External Whisper Box
- Panasonic Smart Control Switch

Note: Air Source Heat Pump, (ASHP), and ancillary equipment shown indicatively. Refer to independent third party designs for exact details of ASHP System

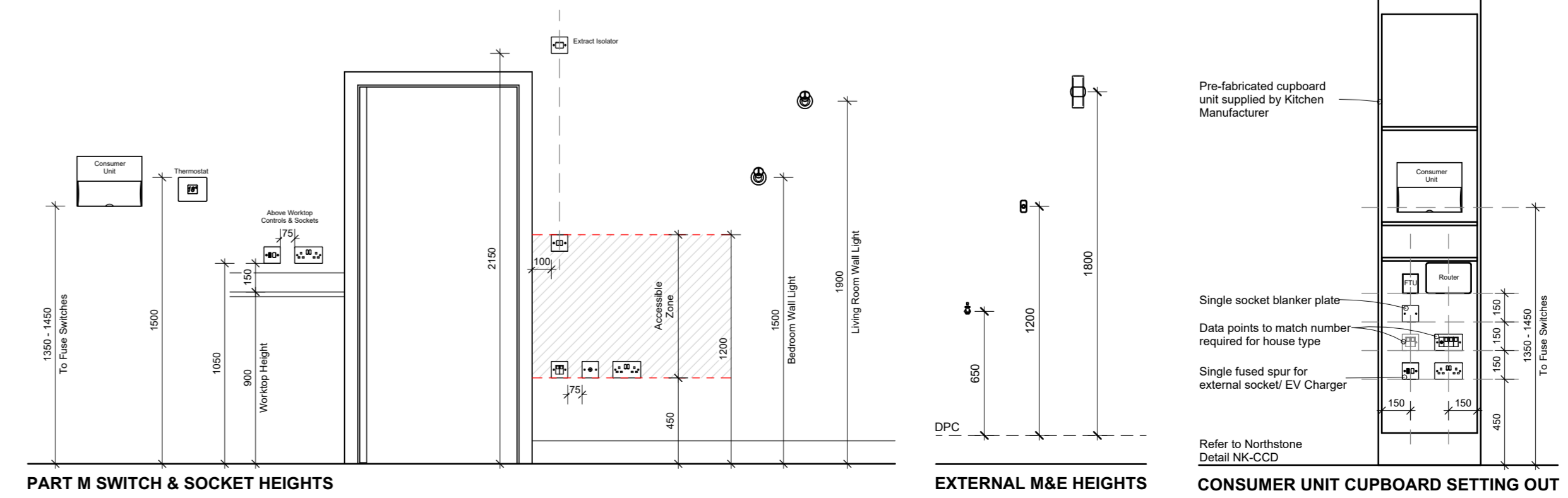

A	General updates as detailed within issue email dated 02.02.2024	Feb 2024
-	Construction Issue	July 2023

Rev Description Date

NORTHSTONE
Peel L&P
Salford
M50 2TG

CONSTRUCTION

PROJECT
Gen2 House Type Portfolio

DRAWING NAME
1045-V3-X (As) MEP Plans

DRAWING NUMBER 1045-330	DESIGNATION X	DRAWN BY Design
DATE June 2023	SCALE (@ A1) As indicated	REV A

Notes:

- All dimensions to structure unless otherwise stated.
- Drawing to be read in conjunction with Northstone specification & all other project related design information and drawings.
- Any discrepancies to be reported to Northstone Technical prior to commencement of works.
- All materials and workmanship to be in accordance with current NHBC Technical Standards and Building Regulations.

DO NOT SCALE FROM THIS DRAWING. ALWAYS PRINT IN COLOUR.

MEMBRANE KEY	
	Damp Proof Course (DPC)
	Damp Proof Membrane (DPM)
	Roof Underlay
	Breather Membrane

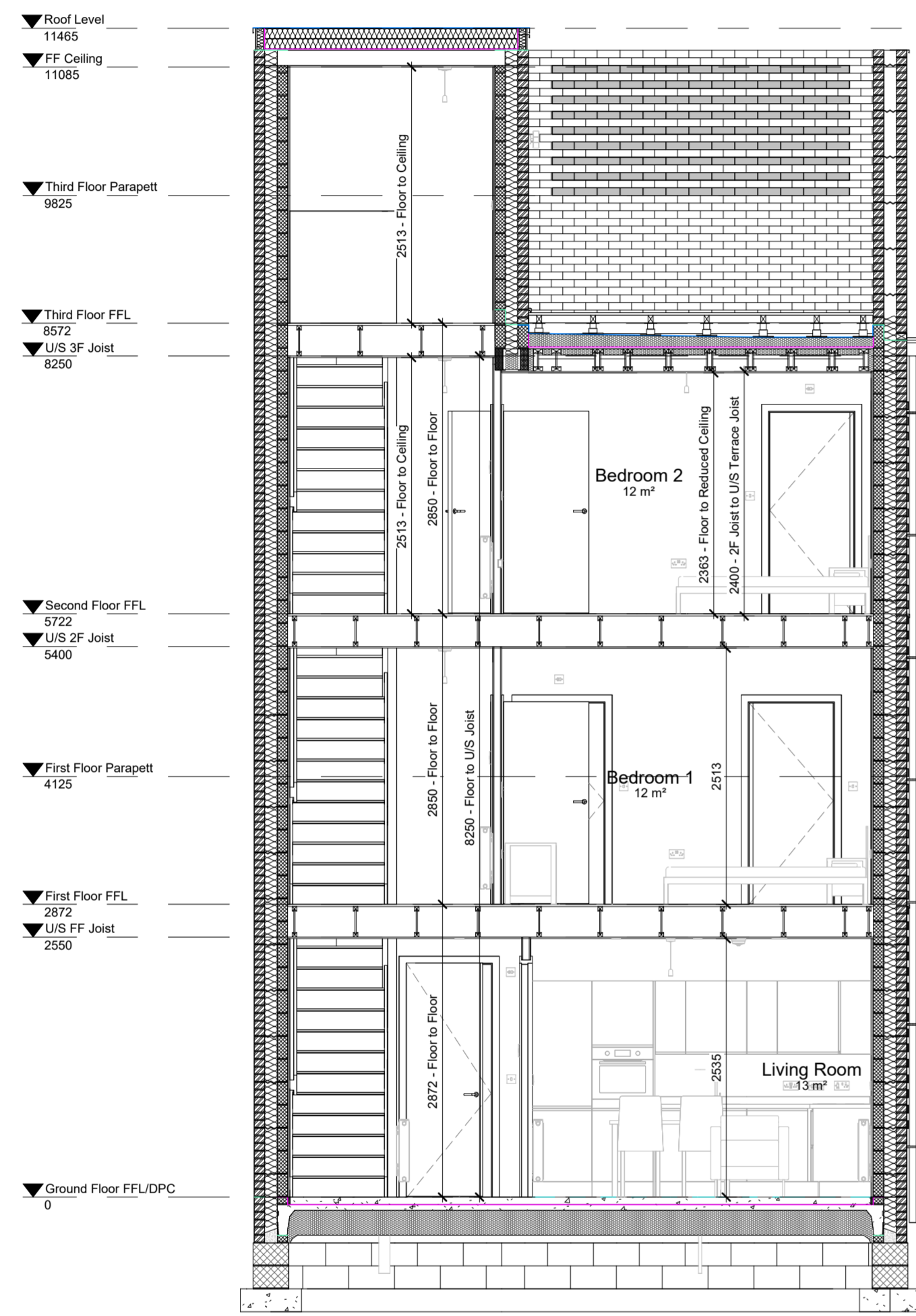

370. Section A-A
1 : 50

Refer to House Type Specific Kingspan Thermapaper Designs for Terrace Insulation Layout

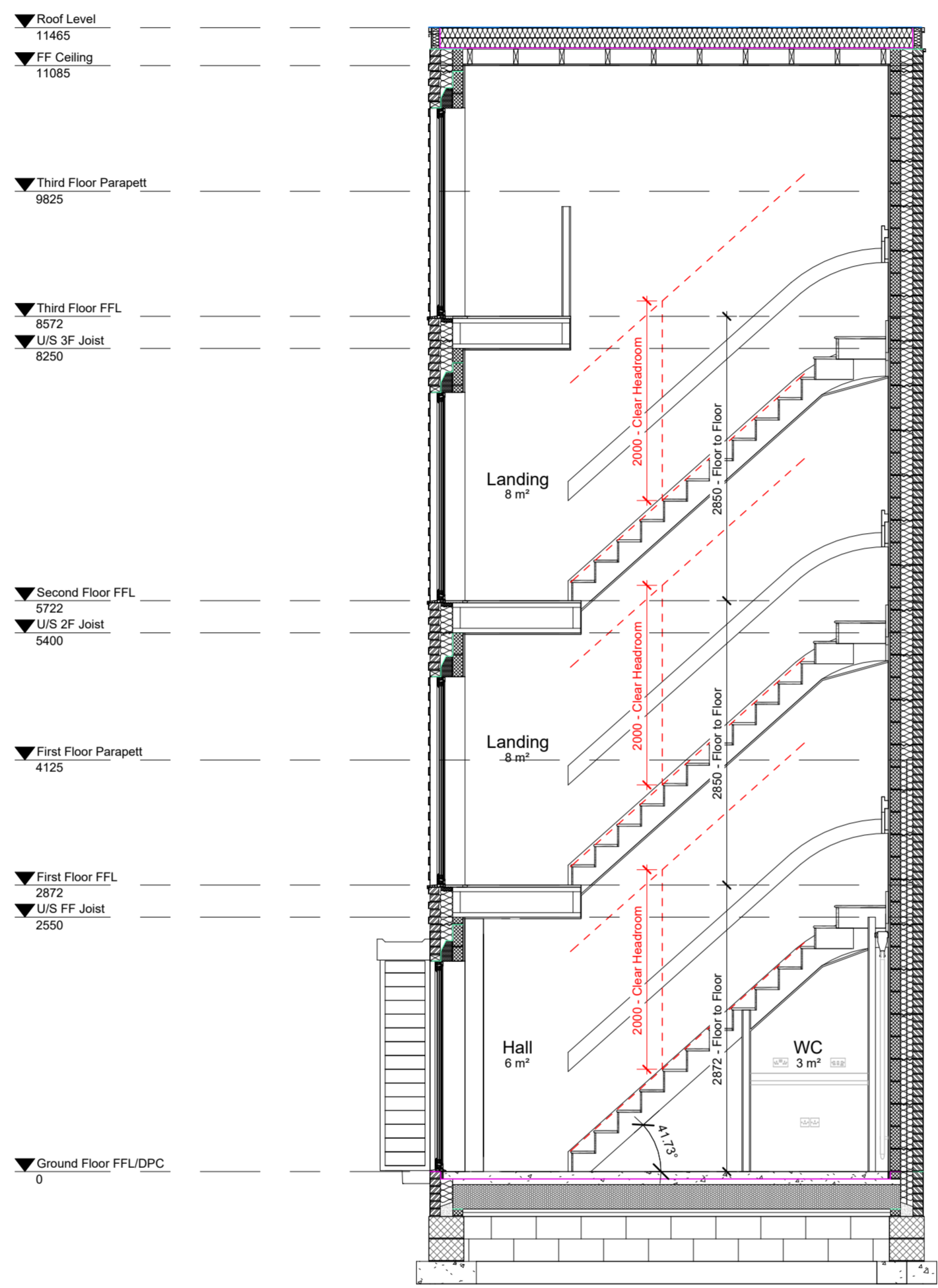

371. Section B-B
1 : 50

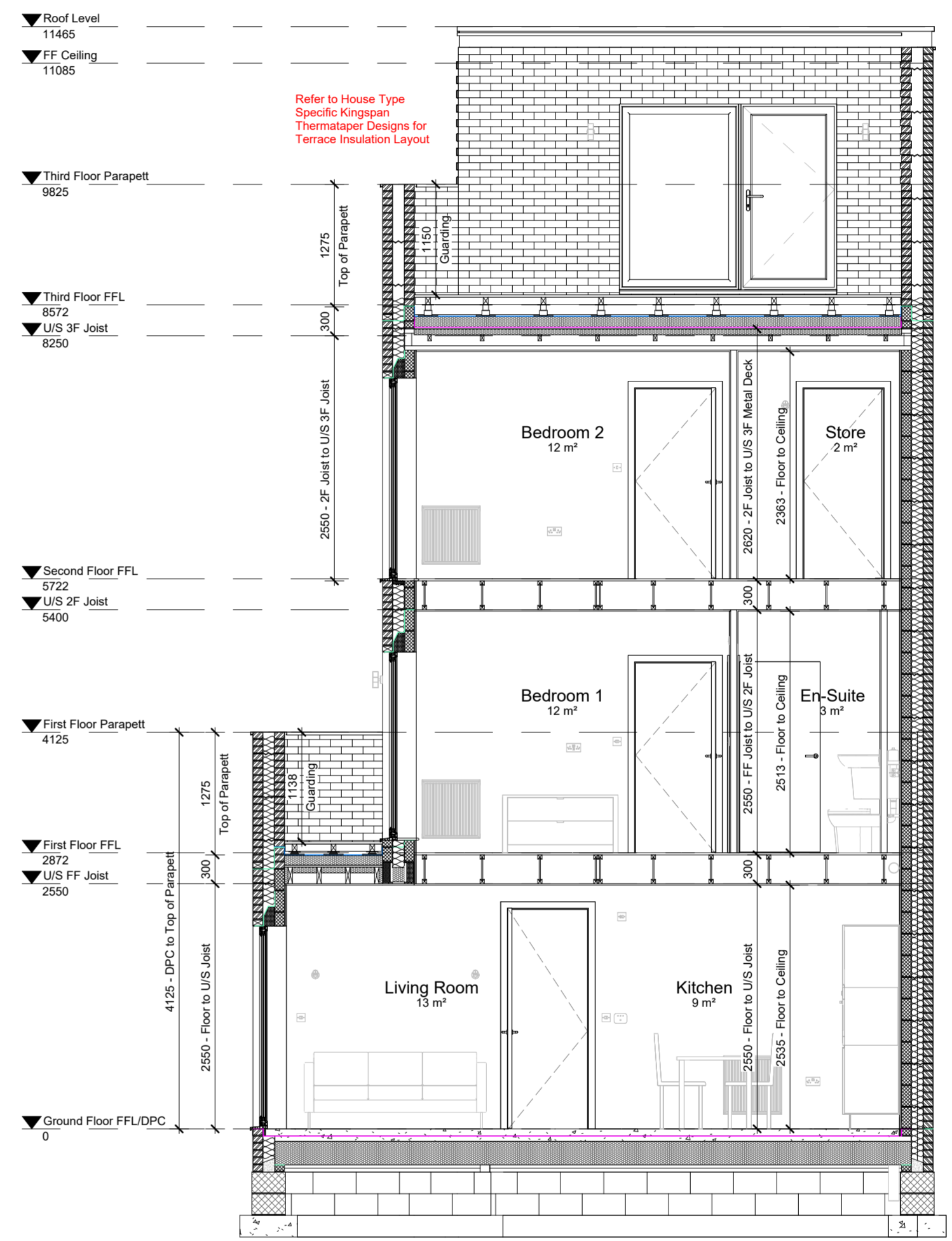

372. Section C-C
1 : 50

Refer to House Type Specific Kingspan Thermapaper Designs for Terrace Insulation Layout

A General updates as detailed within issue email dated Feb 2024
02.02.2024
- Construction Issue July 2023

Rev	Description	Date
1	Construction Issue	July 2023

NORTHSTONE
Peel L&P
Salford
M50 2TG

CONSTRUCTION

PROJECT
Gen2 House Type Portfolio

DRAWING NAME
1045-V3-X (As) Sections

DRAWING NUMBER 1045-350	DESIGNATION X	DRAWN BY Design
DATE June 2023	SCALE (@ A1) 1 : 50	REV A

Notes:

- All dimensions to structure unless otherwise stated.
- Drawing to be read in conjunction with Northstone specification & all other project related design information and drawings.
- Any discrepancies to be reported to Northstone Technical prior to commencement of works.
- All materials and workmanship to be in accordance with current NHBC Technical Standards and Building Regulations.

DO NOT SCALE FROM THIS DRAWING. ALWAYS PRINT IN COLOUR.