

EXISTING CROSS SECTION

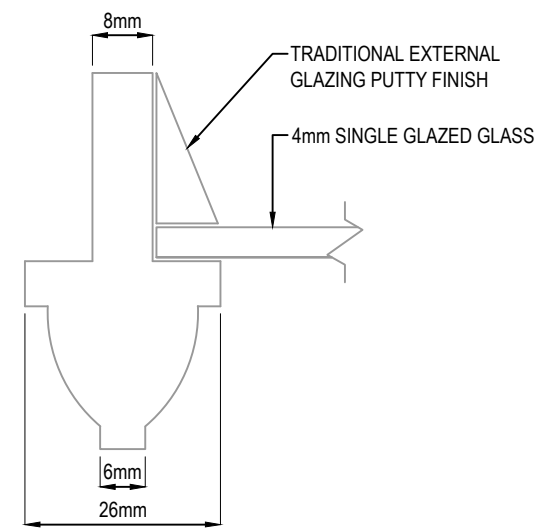
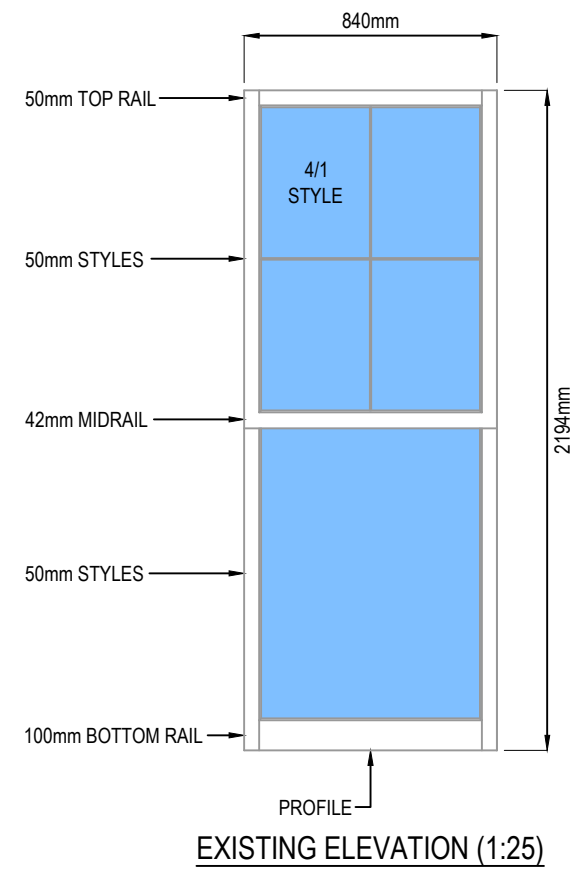

EXISTING ASTRAGAL CROSS SECTION (1:1)

**EAST ELEVATION**

<b>PLANNING ISSUE</b>	
Client:	
Margaret Sullivan, Apartment 4, 47 Sassoon Grove, Edinburgh, EH10 5FB	
Title:	
Double Glazed Upgrade W6 Drawing Room Bay Left Existing Elevation / Sections	
Scale:	Date:
As Noted	February '24
Drawing No.:	
HERM/47SG/W6/DRBL/E	