

L10 WINDOWS/ROOFLIGHTS/SCREENS/LOUVRES

To be read with Preliminaries/General conditions.

PRELIMINARY INFORMATION/REQUIREMENTS

- 110 EVIDENCE OF PERFORMANCE: Provide independently certified evidence that all specified variants of components comply with specified performance requirements. Provide proof of acoustic performance to CA. Installation will be subject to post installation test ing by Approved Inspector or DS.
- 120 SITE DIMENSIONS must be taken and recorded on shop drawings before starting to make all windows
- 140 CONTROL SAMPLES: After finalisation of all details, obtain approval of appearance before proceeding with manufacture and provide sample of paint / PC finish to match existing windows.

SECONDARY GLAZING OPERATION TO MIRROR THAT OF EXISTING WINDOWS.**COMPONENTS**

- 310 ALUMINIUM SECONDARY GLAZING TO FIRST AND SECOND FLOORS:
- Drawing reference(s): ga elevation and window schedule
 - Manufacturer and reference: Selectaglaze
 - Exposure category (Design wind pressure): low
 - Glazing details: single glazed units to window subcontractor's design - all toughened as required by AI/ DS as below , fixed into existing reveals.
 - Any glazing below 800mm of FFL to be of toughened glass to meet Building Regulations. Glass HD / 6.4mm acoustic laminate
 - Weatherstripping: to sub-contactors' detail
 - Ironmongery/accessories:recessed finger pulls to all sashes
 - Finish as delivered: powder coated to standard RAL 9910 semi gloss to BS EN 12206-1:2004.
 - Fixing: to sub-contractors details and DS' approval.
 - Curved windows as noted on schedule to have extension cill.
 - Internally to have 19mm thick bullnosed w'proof MDF window board.
- 460 ROOFLIGHTS: TO MAIN FLATROOF 2 No.
- Manufacturer and reference: Velux AOV 1m2 free area linked to fire alarm / detection system
 - Frame: aluminium
 - Finish: polyester powder coated to BS6497.
 - Colour: standard RAL 9010 black finish

INSTALLATION

- 710 PROTECTION OF COMPONENTS: Do not deliver to site components which cannot be put immediately into suitable clean, dry, floored and covered storage. Stack near vertical on level bearers, separated with spacers to prevent damage by and to projecting ironmongery, beads, etc.
- 730 PRIMING/SEALING: Before fixing components ensure that surfaces of timber which will be inaccessible after installation are primed or sealed as specified.
- 740 CORROSION PROTECTION: Before fixing, apply two coats of bitumen solution to BS 6949 or an approved mastic impregnated tape, to relevant surfaces
- 750 BUILDING IN will not be permitted except where specifically stated on the drawings.
- 765 WINDOW INSTALLATION:
- Install windows into prepared openings, maintaining a maximum gap of 5-10mm between the frame edge and the surrounding construction.
 - Install windows without twist or diagonal racking.
- 770 PREPARED OPENINGS: Ensure that dpcs are positioned correctly in relation to frames and are not displaced during fixing operations.
- 781 FIXING OF aluminium FRAMES:
- As section Z20 to DS' approval
 - When not predrilled or specified otherwise, position fixings not less than 50 mm and not more than 190 mm from each end of jamb, adjacent to each hanging point of opening lights, and at maximum 900 mm centres.
- 790 FIRE RESISTING FRAMES: Completely fill gap between Intumescent foam to DS' approval and reveal with black mastic
- 800 BACKFILLING OF STEEL FRAME SECTIONS: After fixing, fill the back of steel frame sections with a waterproof cement fillet.
- 810 SEALANT JOINTS:
- Sealant manufacturer and reference: _____
 - Colour: to match window frame
 - Prepare joints and apply sealant as section Z22. Finish triangular fillets with a flat or slightly convex profile.
- 820 IRONMONGERY: ALL TO BE PROVIDED BY WINDOW SUBCONTRACTOR. Assemble and fix carefully and accurately using fasteners with matching finish. Prevent damage to ironmongery and adjacent surfaces. At completion check, adjust and lubricate as necessary to ensure correct functioning.

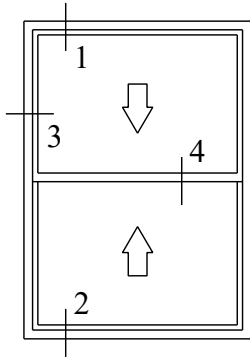

STYLE VSCB

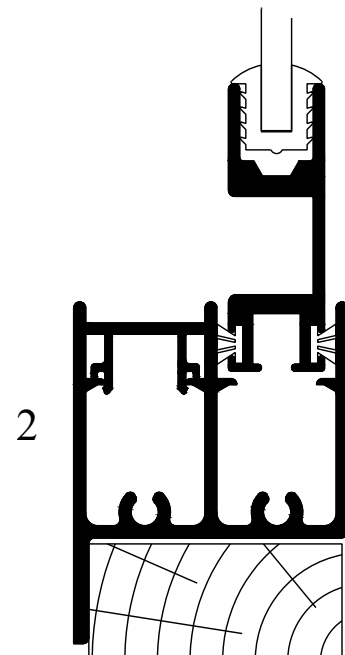
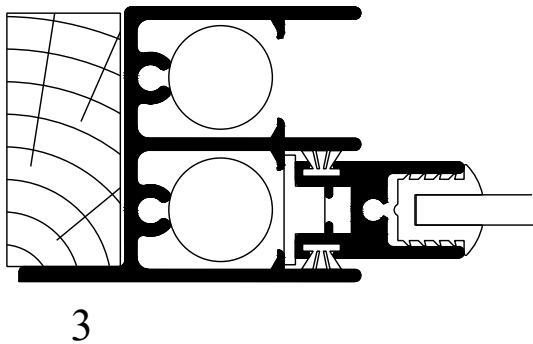
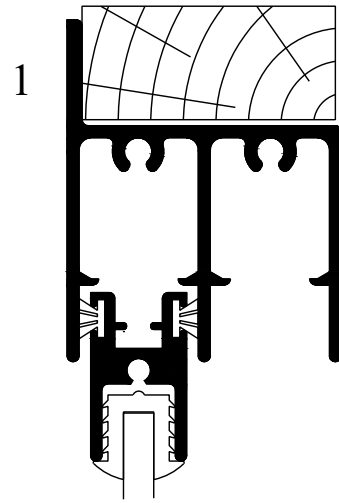

Drawings show standard 33 x 15mm softwood grounds without packing tolerance.
Selectaglaze Ltd. reserves the right to alter any of the sections without prior notice.

SCALE 1:1
(print without scaling)

DRAWN	DATE	ISSUE	AA					
S. THOMPSON	08-11-18	C.N.	18-052					
DESCRIPTION	SERIES 20 EXTENDED COVER VERTICAL SLIDING UNIT							
This document is the property of Selectaglaze Ltd and full copyright is reserved			SHEET 1 OF 2 SHEETS		CAD FILE NAME	DS-222-AA.dwg		
			DATA SHEET NUMBER	DS-222		ISSUE AA		

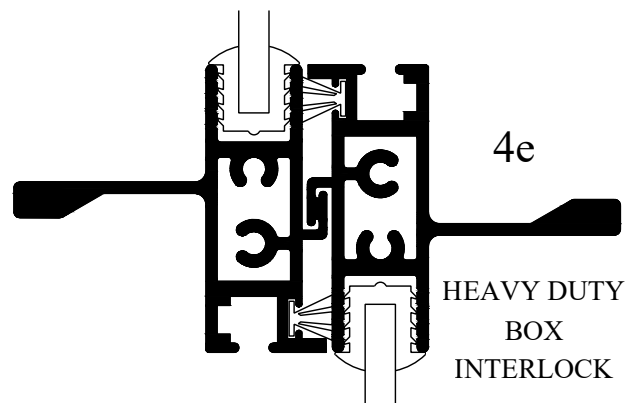
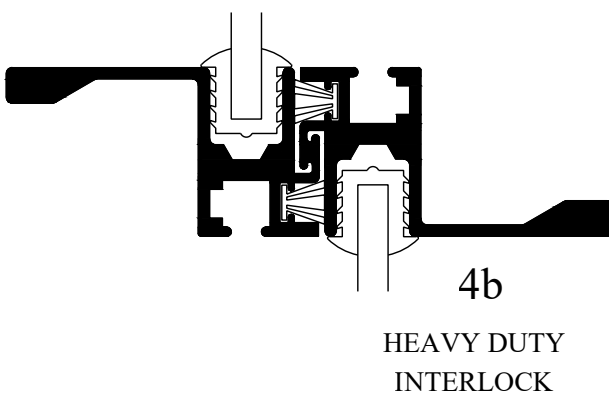
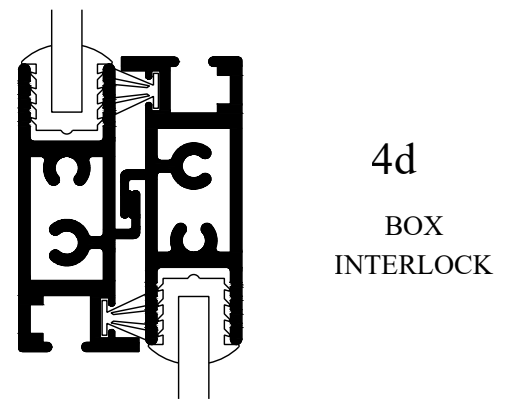
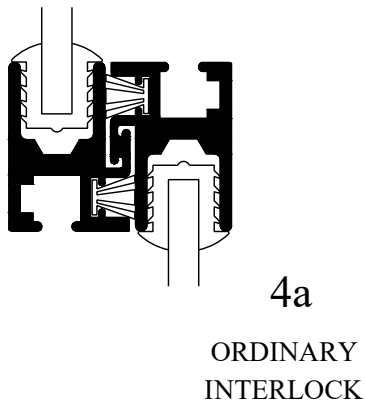
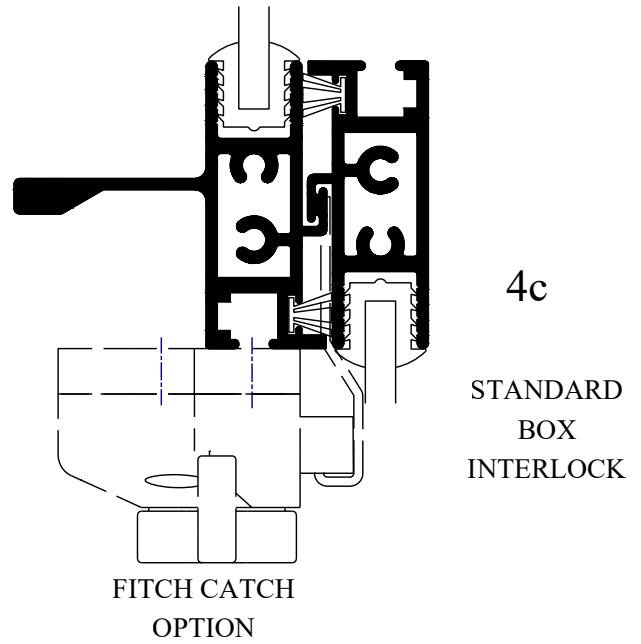
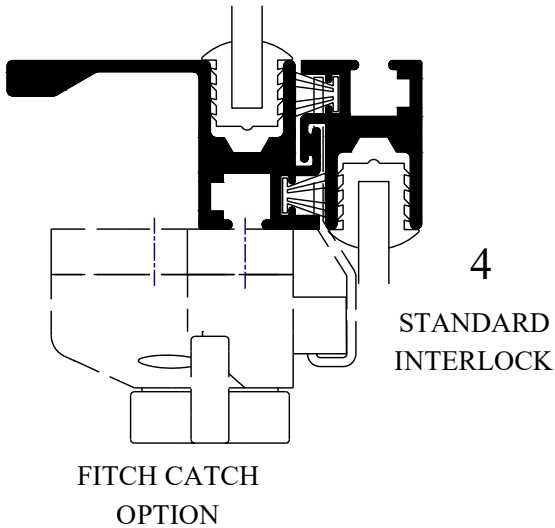

Drawings show standard 33 x 15mm softwood grounds without packing tolerance. Selectaglaze Ltd. reserves the right to alter any of the sections without prior notice.

SCALE 1:1
(print without scaling)

DRAWN	DATE	ISSUE	AA					
S. THOMPSON	08-11-18	C.N.	18-052					
DESCRIPTION	SERIES 20 EXTENDED COVER VERTICAL SLIDING UNIT							
This document is the property of Selectaglaze Ltd and full copyright is reserved				SHEET 2 OF 2 SHEETS		CAD FILE NAME		DS-222-AA.dwg
				DATA SHEET NUMBER		DS-222		ISSUE AA

SERIES 20 VERTICAL SLIDING UNIT

Operating Instructions:

The sashes can slide after releasing any locking catches and the spring balances will support the sash in any position. Avoid any fast movement or slamming action since this will adversely affect the spiral balances. It is recommended that both hands are used when operating the window to ensure even pressure on the balances.

Maintenance:

Cleaning Access: The sashes are attached to the spiral spring balances and cannot be removed. They contra-slide and the rear glass surface can be accessed from above and below. A long handled cleaner may be needed for tall sashes.

Cleaning: The cleaning cycle will be dictated by local conditions and should consist of washing down the glass and aluminium with a non alkaline detergent in warm water using a soft cloth. For more stubborn marks a soft brush or nylon pad should be used. Avoid abrasive cleaners, steel wool, strong acids or alkalis. After cleaning it is advisable to rinse the surfaces with clean water and then wipe dry.

Chips or scratches in a paint finish can be touched in using a matching non cellulose paint and care must be taken not to get this into draught seals or moving parts. Repair of anodised finishes is not practical other than by touching in with a colour matched paint but the finished appearance is seldom complementary.

Balance Adjustment: The spring balances are factory adjusted but in use the tension can change allowing the sash to creep up (over tension) or drop (under tension). Adjustment is carried out using a tensioning tool (available from Selectaglaze). Raise the sash to its highest point and support with a suitable prop. Release the screw on the sash balance retainer and slide it back. Hook the tensioning tool on to the spring spiral and pull down so that the "butterfly" clears its locating slot in the balance foot. Turn the spiral clockwise to increase tension or anti-clockwise to decrease. It is likely that only half a turn will be necessary. The procedure is reversed to re-attach. The balance foot must be flush with the sash when reinstated to avoid any rubbing action on the frame. Check the operation of the sash and ensure that both supporting balances are adjusted to equal tension.

Balance Replacement: If a balance fails, the weight of the sash becomes unsupported. It should be lowered to the bottom of the frame and a warning sign attached. Balance replacement is a specialist operation, refer to Selectaglaze.

Glass Replacement: Re-glazing is a specialist operation, refer to Selectaglaze.

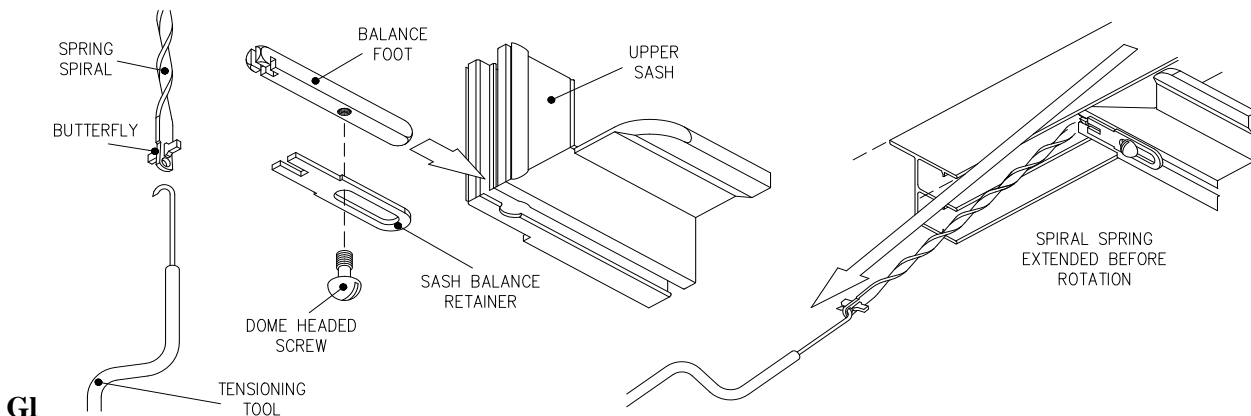

DRAWN	DATE	ISSUE	AA	AB				
S. THOMPSON	31-08-07	C.N.	07/040	15-014				
DESCRIPTION	SERIES 20 – VERTICAL SLIDING UNIT							
This document is the property of Selectaglaze Ltd., and full copyright is reserved			SHEET 1 OF 1 SHEETS		CAD FILE NAME		DS-520-AB.doc	
			DATA SHEET NUMBER	DS-520		ISSUE	AB	