

SASH HORN OPTIONS (Scale 1:2)

Sash Horn Type A

Sash Horn Type B

Sash Horn Type C

Sash Horn Type D

Sash Horn Type E

Sash Horn Type F

Sash Horn Type G

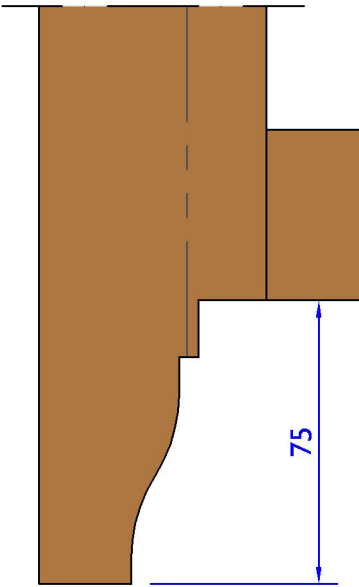
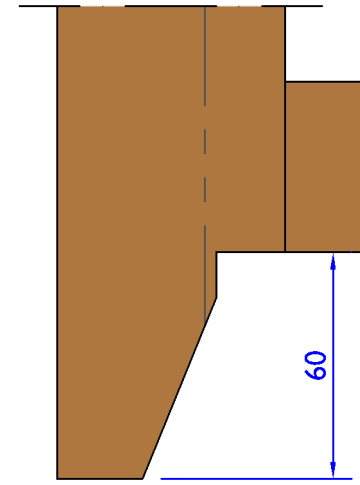
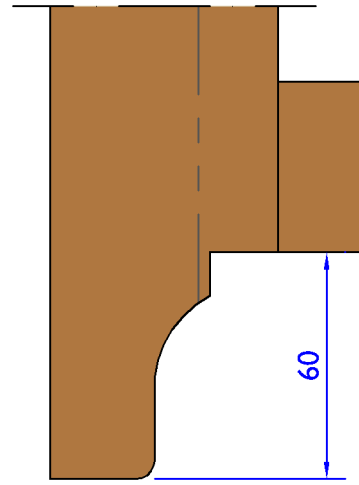
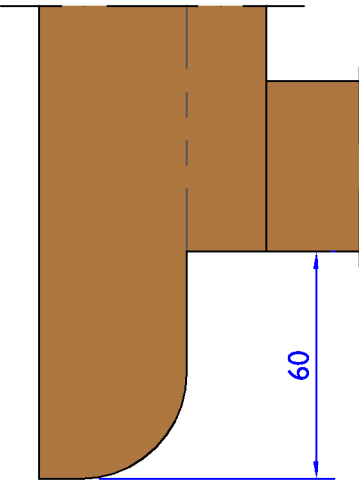
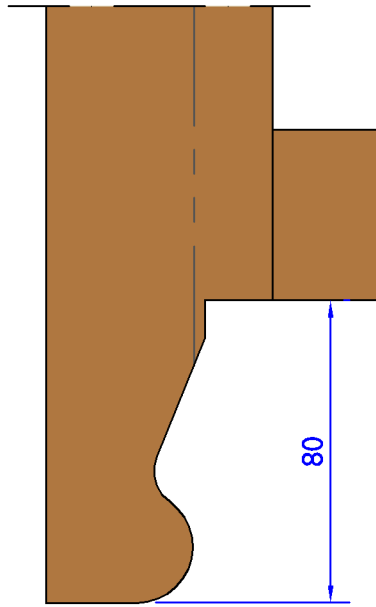
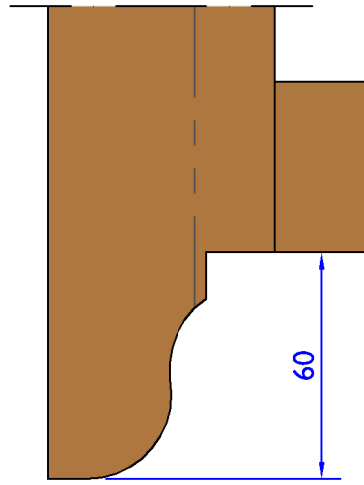
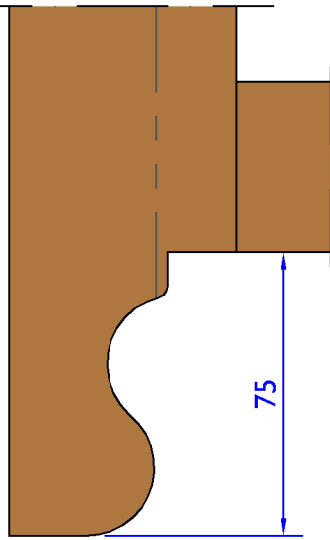

Sash Pull Position

(sash width <900 mm) - (Scale 1:10)

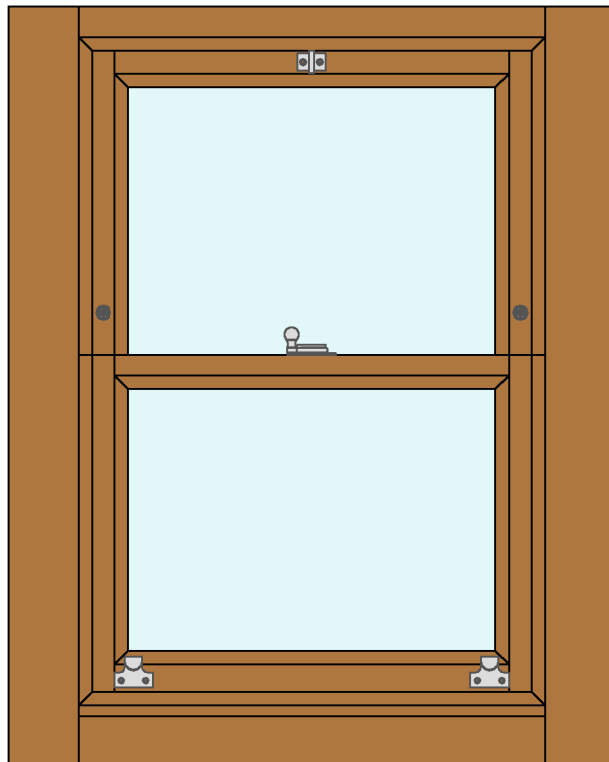

Sash Pull + Fastener Position

(sash width >900 mm) - (Scale 1:10)

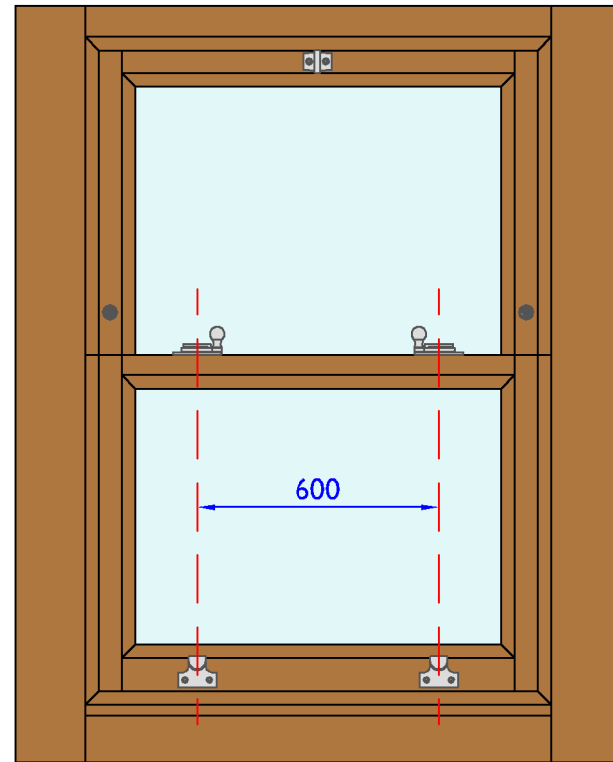

Double Sash Stop Option - (Scale 1:5)

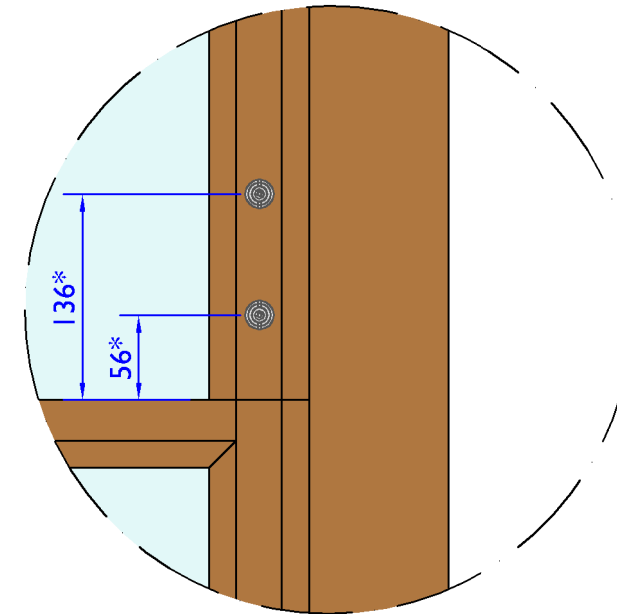

* Dimensions shown provide (100mm and 20mm respectively), ventilation openings at the bottom of the window

Sash pull aligned with sash rebate. Sash fastener centralised unless glazing bar requires it to be offset (offset to RHS when viewed from inside unless specified otherwise)

Sash pull aligned with sash fastener. Pull and fastener position as shown unless glazing bar requires alternative position which should then be positioned for best aesthetic by operator.

— Variable Dimensions
(Dim shown is usually min)

— Fixed Dimensions

System: T-SI-174		
Title: Traditional - Box Sash Window (59mm)		
Scale:	Rev No:	Date:
As Shown	B	26-Mar-18
Drawn By:	Sheet No:	Status:
LH	5	Released