

Installation manual

Terra HP Generation 4 CE Ionity

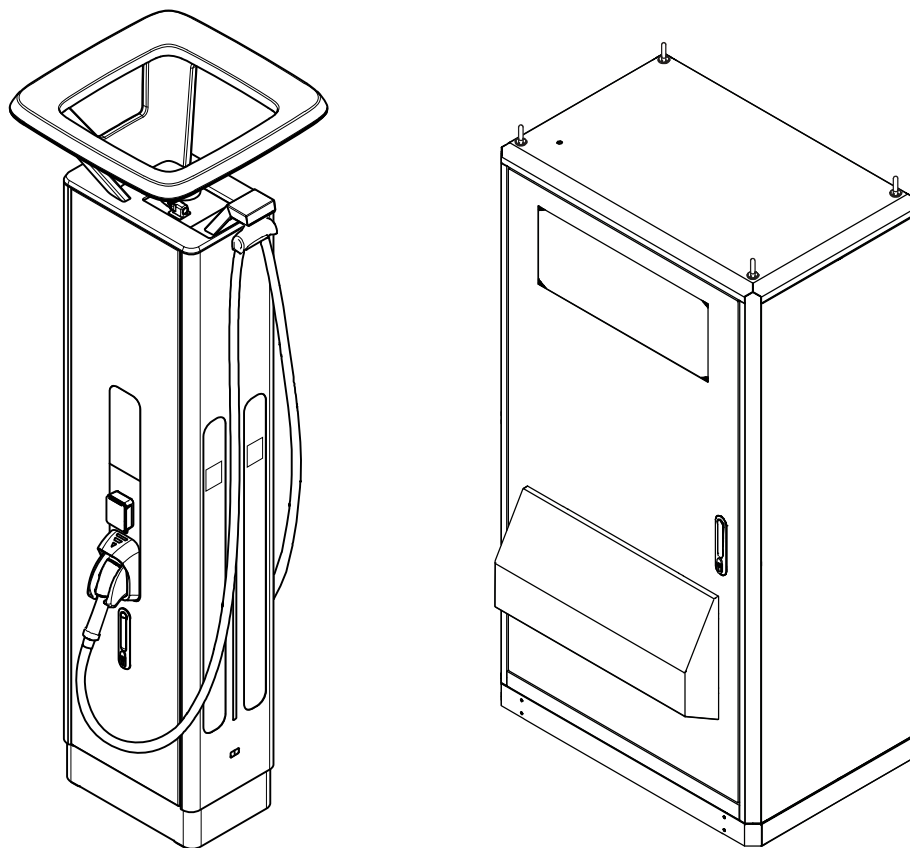

Copyright

All rights to copyrights, registered trademarks, and trademarks reside with their respective owners.

Copyright © ABB E-mobility Inc.. All rights reserved.

Contents

1	About this document.....	8
1.1	Function of this document.....	8
1.2	Target group.....	8
1.3	Revision history.....	8
1.4	Language.....	8
1.5	Illustrations.....	8
1.6	Units of measurement.....	8
1.7	Typographical conventions.....	8
1.8	How to use this document.....	8
1.9	General symbols and signal words.....	9
1.10	Special symbols for warnings and dangers.....	10
1.11	Related documents.....	10
1.12	Manufacturer and contact data.....	10
1.13	Abbreviations.....	11
1.14	Terminology.....	11
1.15	Orientation agreements.....	12
2	Safety.....	13
2.1	Liability.....	13
2.2	General safety instructions.....	13
2.3	Required qualifications for the installation person.....	13
2.4	Personal protective equipment.....	14
2.5	Safety instructions during transport.....	14
2.6	Safety instructions during installation.....	14
2.7	Safety instructions for earthing.....	15
2.8	Signs on the EVSE.....	15
2.9	Discard the EVSE or parts of the EVSE.....	16
2.10	Cyber security.....	16
3	Description.....	18
3.1	Intended use.....	18
3.2	Type plate.....	18
3.3	General description of the EVSE.....	19
3.4	Working principle.....	19
3.5	Overview and functions.....	20
3.5.1	Power cabinet, outside.....	20
3.5.2	Power cabinet, inside.....	21
3.5.3	AC plate.....	22
3.5.4	DC plate.....	23

3.5.5	Cable glands in the power cabinet.....	24
3.5.6	Charge post, outside.....	24
3.5.7	Charge post, inside.....	25
3.5.8	Overview of the cable glands of the charge post.....	26
3.6	Electric Vehicle Site Solution Control 202 (EVSS).....	26
3.7	Tilt Sensor Supply.....	27
3.8	EV charge cable, CCS 2.....	27
3.9	Parking sensor.....	27
3.10	Options.....	27
3.10.1	Authorization to charge.....	27
3.10.2	Payment terminal.....	27
3.10.3	Fiscal metering system.....	28
4	Pre-installation.....	29
4.1	Pre-installation procedure (site planning).....	29
4.2	Prepare the site.....	29
4.3	Make sure that the floor space for the EVSE and the airflow around the EVSE is correct.....	30
4.4	Prepare the foundation.....	30
4.4.1	Prepare the foundation - general procedure.....	30
4.4.2	Prepare a prefab concrete foundation for the power cabinet.....	30
4.4.3	Prepare a metal foundation for the power cabinet.....	31
4.4.4	Prepare a prefab concrete foundation for the charge post.....	32
4.4.5	Prepare a metal foundation for the charge post.....	33
4.4.6	Prepare a custom foundation for the charge post.....	33
4.5	Install the grommet plate for the concrete foundation of the power cabinet.....	34
5	Inspection and transport.....	36
5.1	Transport the EVSE to the site.....	36
5.2	Inspect the EVSE on delivery.....	36
5.3	Do a check on the transport sensors.....	36
5.4	Unpack the EVSE.....	36
5.5	Remove the cabinet from the pallet.....	37
5.6	Transport the EVSE on the site.....	37
5.6.1	General transport procedure.....	37
5.6.2	Tilt the charge post to the vertical position.....	38
5.6.3	Move the cabinet with a forklift truck.....	39
5.6.4	Hoist the cabinet.....	39
6	Installation.....	41
6.1	General installation procedure.....	41
6.2	Mechanical installation of the power cabinet.....	41
6.2.1	Install the power cabinet - general procedure.....	41

6.2.2	Install the cabinet on the foundation.....	42
6.2.3	Install the cover plates of the metal foundation.....	42
6.3	Mechanical installation of the charge post.....	43
6.3.1	Install the charge post - general procedure.....	43
6.3.2	Remove the cable gland plates.....	43
6.3.3	Install the charge post on the foundation.....	44
6.3.4	Install the cable gland plates.....	44
7	Electrical installation of the power cabinet.....	45
7.1	General procedure.....	46
7.2	Connect the PE cable.....	46
7.3	Connect the AC power cables in the power cabinet	47
7.4	Connect the DC power cable in the power cabinet	47
7.5	Connect the AC auxiliary power cable in the power cabinet.....	48
7.6	Connect the interlock and DC guard cables to the power cabinet.....	49
7.7	Connect the Ethernet cable between the power cabinet and the charge post.....	50
8	Electrical installation of the charge post.....	51
8.1	General procedure.....	51
8.2	Connect the PE cable.....	51
8.3	Connect the DC power input cables.....	52
8.4	Connect the AC auxiliary power cable.....	53
8.5	Connect the interlock and DC guard cable.....	54
8.6	Connect the Ethernet cable to the power cabinet.....	54
8.7	Pre-commissioning mode.....	55
9	Prepare for commissioning.....	56
10	Access to parts.....	57
10.1	Open the door of the power cabinet.....	57
10.2	Remove the plinth covers of the power cabinet.....	57
10.3	Open the DC door.....	58
10.4	Remove the AC cover.....	58
10.5	Close the door of the power cabinet.....	59
10.6	Open the door of the charge post.....	60
10.7	Remove the plinth covers of the charge post.....	60
10.8	Remove the protection plate of the charge post.....	61
10.9	Install the AC cover.....	61
10.10	Close the DC door.....	62
10.11	Close the door of the charge post.....	62
11	Generic procedures.....	64
11.1	Install a cable lug on a wire.....	64
11.2	Install a ferrule on a wire.....	64

11.3	Install insulating heatshrink tubing on a wire.....	65
11.4	Connect a wire that has a cable lug.....	66
11.5	Connect a wire that has a ferrule.....	66

12 Technical data.....67

12.1	EVSE type.....	67
12.2	Parts included in the delivery.....	67
12.3	Required tools for installation.....	68
12.4	Required parts for installation.....	68
12.5	General specifications.....	69
12.6	Electrical installation specifications.....	70
12.6.1	General requirements.....	70
12.6.2	Requirements for precomissioning.....	70
12.6.3	Requirements for charge post auxiliary.....	71
12.7	DC output specifications.....	71
12.8	Current peaks during the start of a charge session (DC output).....	72
12.9	Logic interfaces specifications.....	72
12.10	Mass and center of gravity.....	72
12.10.1	Mass.....	72
12.10.2	Center of gravity, power cabinet.....	72
12.10.3	Center of gravity, charge post.....	73
12.11	Ambient conditions.....	73
12.12	Noise level.....	74
12.13	Torque specifications.....	74
12.14	Dimensions.....	75
12.14.1	Power cabinet.....	75
12.14.2	Charge post.....	75
12.14.3	Height of user operable elements.....	76
12.15	Space requirements.....	77
12.15.1	Power cabinet.....	77
12.15.2	Charge post.....	78
12.15.3	Charge post: exceptions for bollards and other minor fixed obstacles.....	79
12.15.4	Distance requirements between power cabinet and charge post.....	80
12.16	Foundation specifications.....	81
12.16.1	Power cabinet (prefab concrete).....	81
12.16.2	Power cabinet (metal frame).....	84
12.16.3	Gland plates for the metal foundation of the power cabinet.....	85
12.16.4	Charge post (metal frame).....	86
12.16.5	Charge post (prefab concrete).....	87
12.16.6	Gland plates for the metal foundation of the charge post.....	89
12.16.7	Charge post (custom).....	90
12.17	Overview of the cable conduits.....	91
12.18	Cable specifications.....	92
12.18.1	AC input cable for the power cabinet.....	92

12.18.2	DC power installation cables	93
12.18.3	PE cable.....	93
12.18.4	AC auxiliary power cables.....	94
12.18.5	Interlock and DC guard cables.....	94
12.18.6	Ethernet cable between the power cabinet and the charge post.....	95
12.19	Electrical connection diagram.....	96
12.20	Expected wye input.....	97

13 Appendix..... 98

13.1	Hinweise zur Messgenauigkeit entsprechend der Baumusterprüfbescheinigung....	98
------	--	----

1 About this document

1.1 Function of this document

The document is only applicable for this EVSE: Terra HP Generation 4 Ionity, including the variants and options listed in section 12.1.

The document gives the information that is necessary to install the EVSE.

1.2 Target group

The document is intended for qualified installation persons.

For a description of the required qualifications, refer to section 2.3.

1.3 Revision history

Version	Date	Description
001	May 2022	Initial version
002	June 2022	Alignement from first feedbacks
003	September 2022	Released version
004	November 2022	Pre-commissioning info

1.4 Language

The original instructions of this document are in English (EN-US). All other language versions are translations of the original instructions.

1.5 Illustrations

It is not always possible to show the configuration of your EVSE. The illustrations in this document show a typical setup. They are for instruction and description only.

1.6 Units of measurement

SI units of measurement (metric system) are used. If necessary, the document shows other units between parentheses () or in separate columns in tables.

1.7 Typographical conventions











The lists and steps in procedures have numbers (123) or letters (abc) if the sequence is important.

1.8 How to use this document

1. Make sure that you know the structure and contents of this document.
2. Read the safety chapter and make sure that you know all the instructions.
3. Do the steps in the procedures fully and in the correct sequence.
4. Keep the document in a safe location that you can easily access. This document is a part of the EVSE.

1.9





General symbols and signal words

Signal word	Description	Symbol
Danger	If you do not obey the instruction, this can cause injury or death.	Refer to section 1.10.
Warning	If you do not obey the instruction, this can cause injury.	Refer to section 1.10.
Caution	If you do not obey the instruction, this can cause damage to the EVSE or to property.	
Note	A note gives more data, to make it easier to do the steps, for example.	
-	Information about the condition of the EVSE before you start the procedure.	
-	Requirements for personnel for a procedure.	
-	General safety instructions for a procedure.	
-	Information about spare parts that are necessary for a procedure.	
-	Information about support equipment that is necessary for a procedure.	
-	Information about supplies (consumables) that are necessary for a procedure.	
-	Make sure that the power supply to the EVSE is disconnected.	
-	Electrotechnical expertise is required, according to the local rules.	
-	Alternating current supply	



Note: It is possible that not all symbols or signal words are present in this document.

1.10 Special symbols for warnings and dangers

Symbol	Risk type
	General risk
	Hazardous voltage that gives risk of electrocution
	Risk of pinching or crushing of body parts
	Rotating parts that can cause a risk of entrapment
	Hot surface that gives risk of burn injuries



Note: It is possible that not all symbols are present in this document.

1.11 Related documents

Document name	Target group
Product data sheet	All target groups
Installation manual	Qualified installation person
EVSS Installation manual	Qualified installation person
User manual	Owner
Service manual	Qualified service engineer
Declaration of conformity (CE)	All target groups

1.12 Manufacturer and contact data

Manufacturer
 ABB E-mobility Inc.
 Heertjeslaan 6
 2629 JG Delft

The Netherlands

Contact data

ABB E-mobility Inc. in your country can give you support on the EVSE. You can find the contact data here: <https://new.abb.com/ev-charging>

1.13

Abbreviations

Abbreviation	Definition
AC	Alternating current
BESS	Battery energy storage system
CAN	Controller area network
CPU	Central processing unit
DC	Direct current
EMC	Electromagnetic compatibility
EV	Electric vehicle
EVSE	Electric vehicle supply equipment
MID	Measuring Instruments Directive
NFC	Near field communication
NoBo	Notified body
OCPP	Open charge point protocol
PE	Protective earth
PPE	Personal protective equipment
RFID	Radio-frequency identification



Note: It is possible that not all abbreviations are present in this document.

1.14

Terminology

Term	Definition
Network operating center of ABB EV Infrastructure	Facility of the manufacturer to do a remote check on the correct operation of the EVSE
Cabinet	Enclosure of the EVSE, including the components on the inside
Cable slack	Extra length of cable from the top of the foundation so that the cable length is sufficient to connect to the correct terminal in the cabinet
CCS	Combined Charging System, a standard charging method for electric vehicles
CHAdeMO	Abbreviation of <i>CHArge de MOve</i> , a standard charging method for electric vehicles
Contractor	Third party that the owner or site operator hires to do engineering, civil and electrical installation work

Term	Definition
Grid provider	Company that is responsible for the transport and distribution of electricity
Local rules	All rules that apply to the EVSE during the entire lifecycle of the EVSE. The local rules also include the national laws and regulations
Open charge point protocol	Open standard for communication with charge stations
Owner	Legal owner of the EVSE
Site operator	Entity that is responsible for the day-to-day control of the EVSE. The site operator does not have to be the owner
User	Owner of an EV, who uses the EVSE to charge the EV



Note: It is possible that not all terms are present in this document.

1.15 Orientation agreements

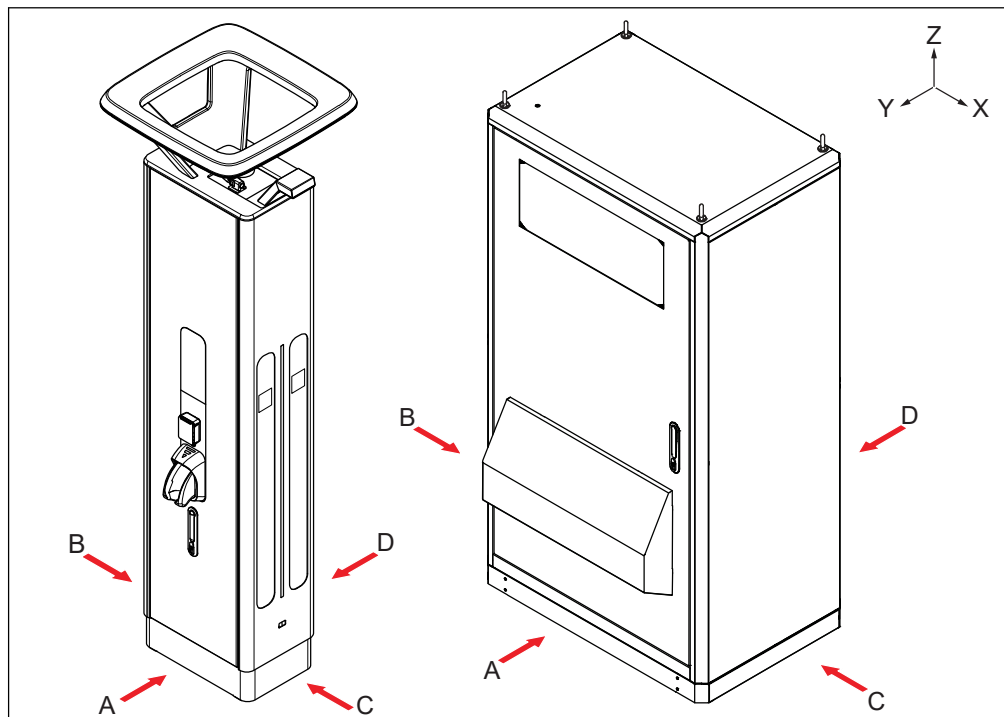

- A Front side: face forward to the EVSE during normal use
- B Left side
- C Right side
- D Rear side

- X X-direction (positive is to the right)
- Y Y-direction (positive is rearward)
- Z Z-direction (positive is upward)

2 Safety

2.1 Liability

The manufacturer is not liable to the purchaser of the EVSE or to third parties for damages, losses, costs or expenses incurred by the purchaser or third parties if any target group mentioned in the related documents does not obey the rules below:

- Obey the instructions in the related documents. Refer to section 1.11.
- Do not misuse or abuse the EVSE.
- Only make changes to the EVSE, if the manufacturer approves in writing of the changes.

2.2 General safety instructions

- This document, the related documents and the warnings included do not replace your responsibility to use your common sense when you do work on the EVSE.
- Only do the procedures that the related documents show and that you are qualified for.
- Obey the local rules and the instructions in this manual. If the local rules contradict the instructions in this manual, the local rules will apply.





If and to the extent permitted by law, in case of inconsistency or contradiction, between any requirements or procedure contained in this document and any such local rules, obey the stricter between the requirements and procedures specified in this document and the local rules.

2.3 Required qualifications for the installation person







- The qualified installation person knows the EVSE and its safe installation.
- The installation person is qualified according to the applicable local rules to do the work.
- The qualified installation person obeys all local rules and the instructions in the installation manual.
- It is the responsibility of the owner of the EVSE to make sure that all qualified installation persons obey the local rules, the installation instructions, and the specifications of the EVSE.

2.4 Personal protective equipment

Symbol	Description
	Protective clothing
	Safety gloves
	Safety shoes
	Safety glasses

2.5 Safety instructions during transport









Preliminary requirements

	• Installation engineer		•  
---	-------------------------	---	---

- Make sure that the hoisting equipment or forklift truck can lift the EVSE safely. Take into account the mass and the center of gravity of the EVSE.
- Obey the safety instructions that apply to the hoisting equipment or the forklift truck.
- Put on the correct personal protective equipment. Refer to section 2.4.

2.6 Safety instructions during installation

Preliminary requirements

	•  Installation engineer		•     
---	--	---	--

- Make sure that there is no voltage on the AC input cables during the complete installation procedure.
- Keep unqualified personnel at a safe distance during installation.
- Only use electrical wires of sufficient gauge and insulation to handle the rated current and voltage demand.

- Make sure that the load capacity of the grid is in accordance with the EVSE.
- Earth the EVSE correctly. Refer to section 2.7.
- Make sure that the wiring inside the EVSE is protected from damage and cannot get trapped when you open or close the cabinet.
- Make sure that water cannot enter the cabinet.
- Protect the EVSE with safety devices and measures that the local rules specify.
- If it is necessary to remove safety devices, immediately install the safety devices after the work.
- Put on the correct personal protective equipment. Refer to section 2.4.

2.7 Safety instructions for earthing



Preliminary requirements



- Make sure that the EVSE is connected to a grounded, metal, permanent wiring system, or an equipment-grounding conductor must be run with the circuit conductors and connected to the equipment grounding terminal or lead on the product.
- Make sure that the connections to the EVSE comply with all applicable local rules.

2.8 Signs on the EVSE

Symbol	Description
	General risk
	Hazardous voltage that gives risk of electrocution
	Risk of pinching or crushing of body parts
	Rotating parts that can cause a risk of entrapment
	Hot surface that gives risk of burn injuries

Symbol	Description
	Appliance class 1
	Sign that means that you must read the manual before you install the EVSE
	Waste from electrical and electronic equipment



Note: It is possible that not all symbols are present on the EVSE.

2.9 Discard the EVSE or parts of the EVSE

Incorrect waste handling can have a negative effect on the environment and human health due to potential hazardous substances. With the correct disposal of this product, you contribute to reuse and recycling of materials and protection of the environment.

- Obey the local rules to discard parts, packaging material or the EVSE.
- Discard electrical and electronic equipment separately in compliance with the WEEE - 2012/19/EU Directive on waste of electrical and electronic equipment.
- As the symbol of the crossed out wheeled-bin on your EVSE indicates, do not mix or dispose the EVSE with your household waste, at the end of use. Instead, hand the EVSE over to your local community waste collection point for recycling.
- For more information, contact the Government Waste-Disposal department in your country.

2.10 Cyber security



Note: This topic is valid for a wired Ethernet connection.

This product is designed to be connected to and to communicate information and data via a network interface. It is the Owner's sole responsibility to provide and continuously ensure a secure connection between the product and Owner's network or any other network (as the case may be).

The Owner shall establish and maintain any appropriate measures (such as but not limited to the installation of firewalls, application of authentication measures, encryption of data, installation of anti-virus programs, etc) to protect the product, the network, its system and the interface against any kind of security breaches, unauthorized access, interference, intrusion, leakage and/or theft of data or information.

The manufacturer (ABB E-mobility Inc.) and its affiliates are not liable for damages and/or losses related to such security breaches, any unauthorized access, interference, intrusion, leakage and/or theft of data or information.

3 Description

3.1 Intended use

The EVSE is intended for DC high power charging of EVs. The EVSE is intended for indoor or outdoor use.

- The properties of the electrical grid, the ambient conditions and the EV must comply with the technical data of the EVSE. Refer to chapter 12.
- Only use the EVSE with accessories that are approved by the manufacturer (ABB E-mobility Inc.) and that obey the local rules.
- Do not use power cabinets from this EVSE with power cabinets from different EVSEs.

Danger:



General risk

- If you use the EVSE in any other way than described in the related documents, you can cause death, injury and damage.
- Use the EVSE only as intended.

3.2 Type plate

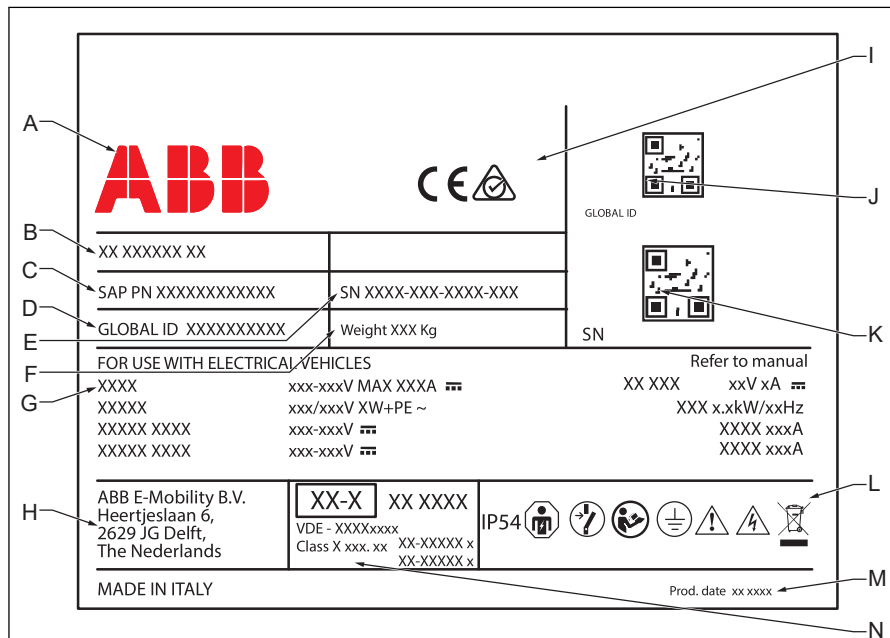

- | | | | |
|---|--|---|---|
| A | Manufacturer | I | CE mark |
| B | Full EVSE type | J | QR code with the internal product code (for the manufacturer) |
| C | Part number of the EVSE | K | QR code with the serial number of the EVSE |
| D | Serial number | L | Additional EVSE rating data |
| E | Internal product code (for the manufacturer) | M | Production date |
| F | EVSE mass | N | MID certified charger identification |
| G | EVSE rating | | |
| H | Address of the manufacturer | | |



Note: The data in the illustration are only examples. Find the type plate on your EVSE to see the applicable data. Refer to section 3.5.1. For the EVSE type information, refer to section 12.1.



Note: For the German market the charge post is equipped with energy metering to comply with the 2014/32/EU MID directive. The energy meter is a field installable device.

3.3 General description of the EVSE

The EVSE is an arrangement of these parts:

- Distribution board
- Power cabinet
- Charge post
- EVSS 202 box
- Tilt sensor supply box

An arrangement can have one power cabinet and one or more charge posts. For the specifications of the configuration in this manual, refer to section 3.4.





3.4 Working principle

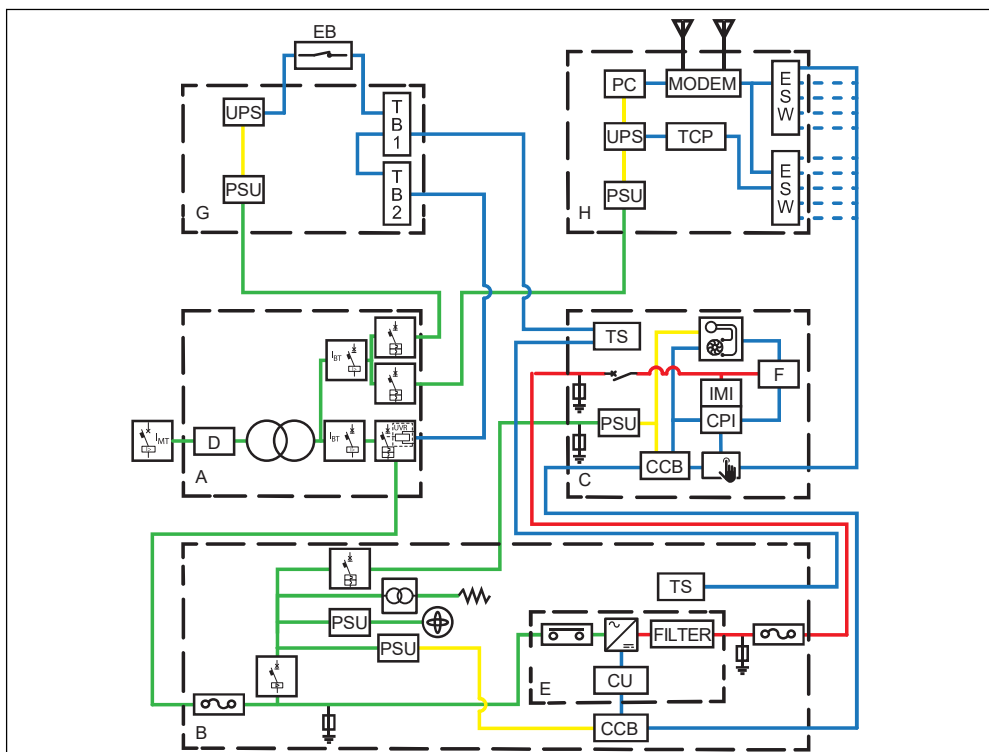

Note: For a detailed overview of the electrical connections, refer to section 12.19.



- | | | | |
|---|------------------------|-----|----------------------|
| A | Substation | G | Tilt sensor box |
| B | Power cabinet | H | EVSS control box |
| C | Charge post | ESW | Ethernet switch |
| D | Electrical grid supply | TS | Tilt sensor |
| E | Power blocks (x4) | TCP | ModBus TCP converter |
| F | EV charge cable | EB | Emergency button |

Lines	Description
	AC input power connections
	DC power connections
	Control lines (general)
	DC auxiliary power supply line

3.5 Overview and functions

3.5.1 Power cabinet, outside

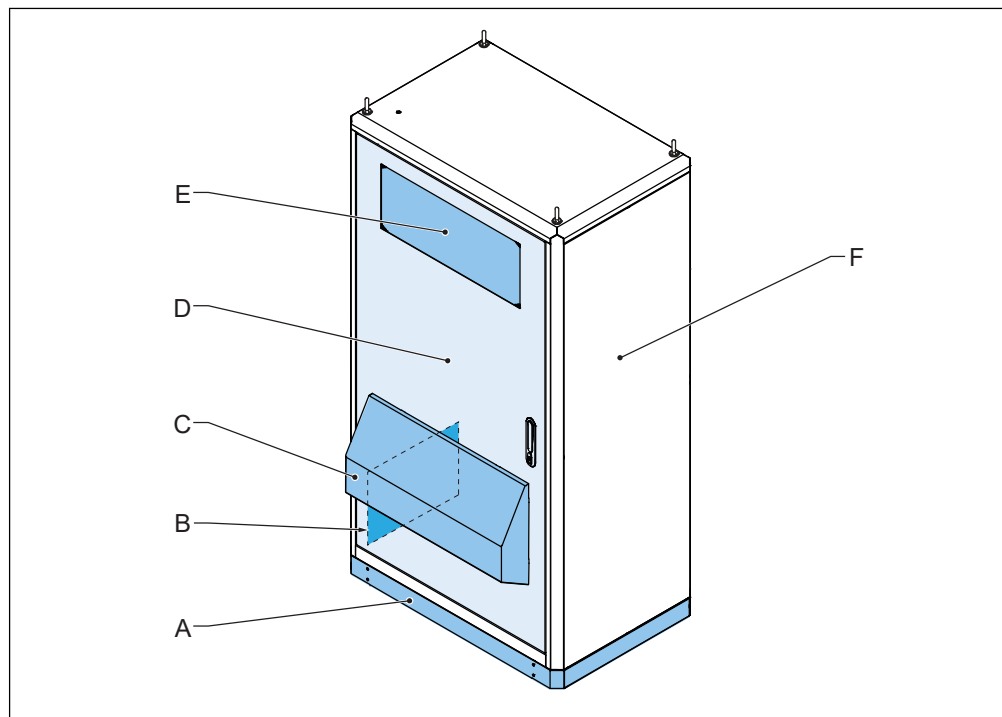

A	Plinth cover	D	Door
B	Type plate	E	Air outlet
C	Silenced air intake	F	Enclosure

Part	Function
Plinth cover	To cover the bottom part of the EVSE
Air inlet and outlet	To let the air in and out. The airflow prevents overheating of the parts on the inside of the EVSE
Type plate	To show the identification data of the power cabinet
Door	To give authorized personnel access to the inside of the cabinet
Enclosure	To reduce the accessibility of unqualified persons to the inside of the cabinet

3.5.2

Power cabinet, inside

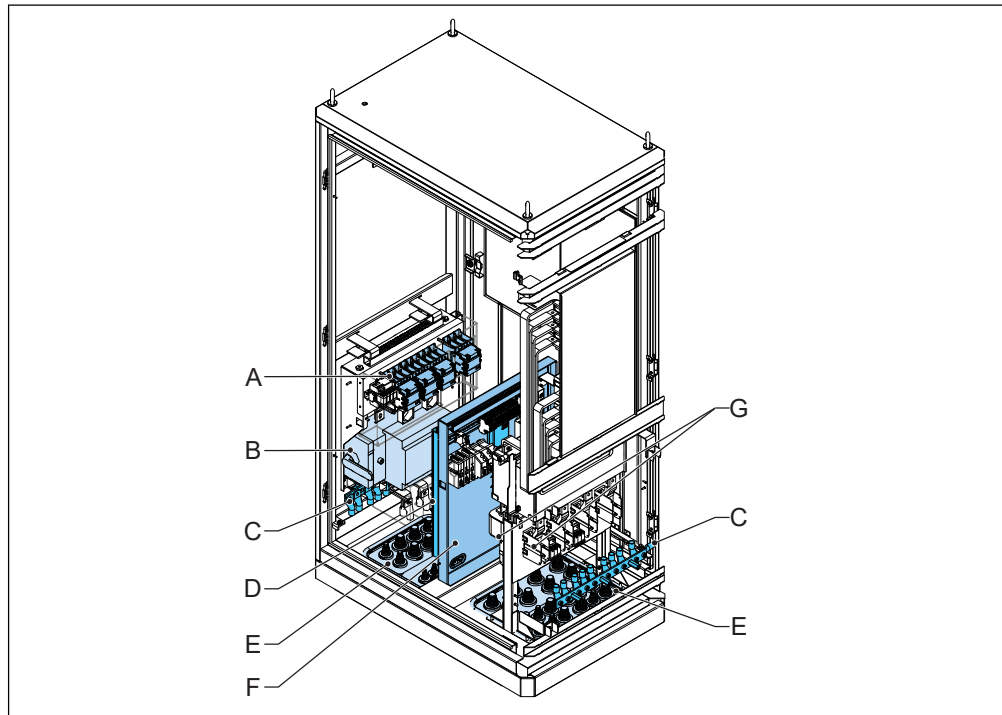

A	AC contactor	E	Cable inlet
B	Main switch	F	DC plate
C	PE busbar	G	DC output terminal block
D	AC plate		

Part	Function
AC contactor	To connect the AC power
Main switch	To connect or disconnect the AC power
PE busbar	To connect PE cables
AC plate	To connect the AC and the precommissioning cables
Cable inlet	Opening for the cables
DC plate	To connect the interlock and LED cables
DC output terminal block	To connect the DC output power cables

3.5.3

AC plate

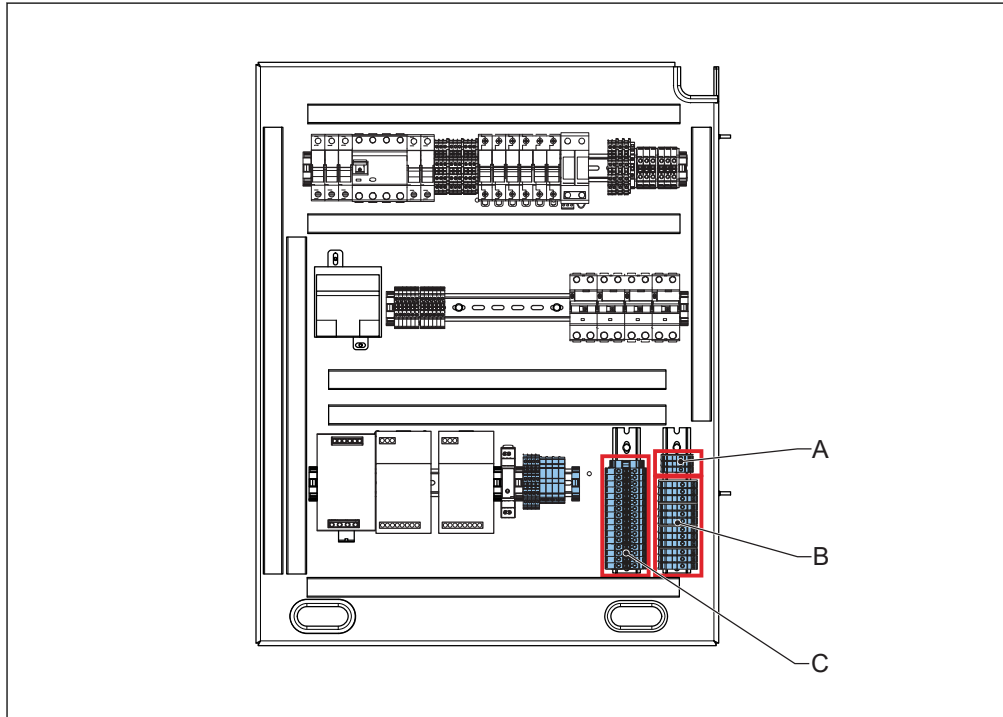

A Terminal X1
B Terminal X2

C Terminal X3

Part	Function
Terminal X1	To connect the precommissioning cables
Terminal X2	To connect the AC cables
Terminal X3	To connect the AC cables

3.5.4

DC plate

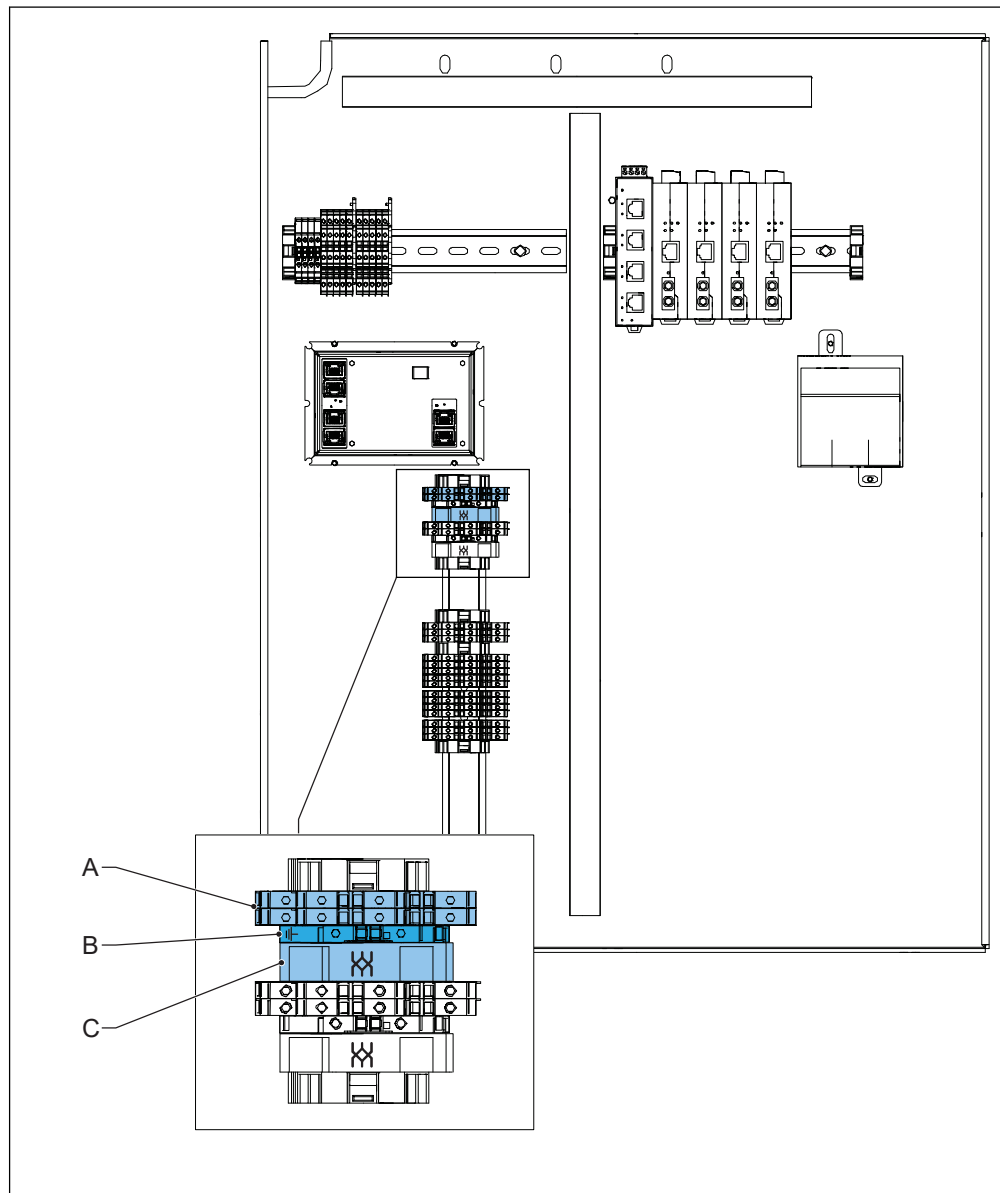

A Terminal X4

B Earthing terminal

C Ethernet connector

Part	Function
Terminal X4	To connect the interlock and DC guard cables
Earthing terminal	To connect the ground wire or shield mesh
Ethernet connector	To connect the Ethernet cable between power cabinet and charge post

3.5.5 Cable glands in the power cabinet

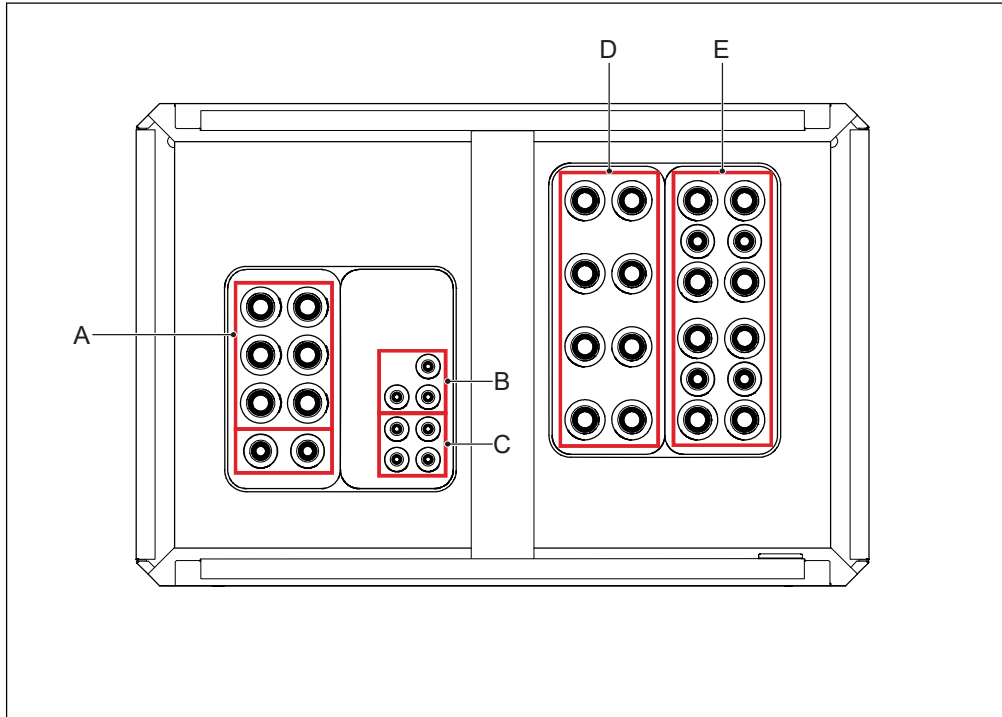

- | | | | |
|---|--|---|------------------------|
| A | AC and PE cable | D | DC+ |
| B | Charge post interconnection signals | E | DC- and PE connections |
| C | AC Charge post line feeding and AC precommissioning line input | | |

3.5.6 Charge post, outside

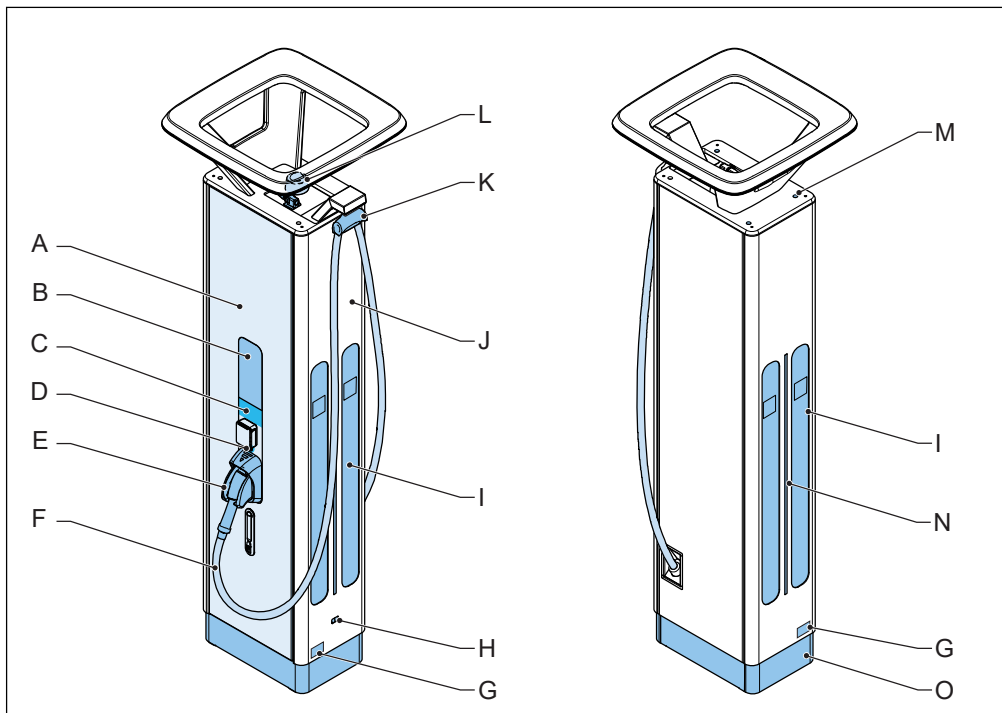

- A Door
- B Touchscreen
- C RFID reader and the payment terminal (option)
- D Stop button
- E Connector holder
- F EV charge cable
- G Type plate
- H Parking sensor
- I Air inlet and outlet
- J Enclosure
- K Cable retraction system
- L Antenna
- M Hoisting points
- N LED strip
- O Plinth cover

3.5.7 Charge post, inside

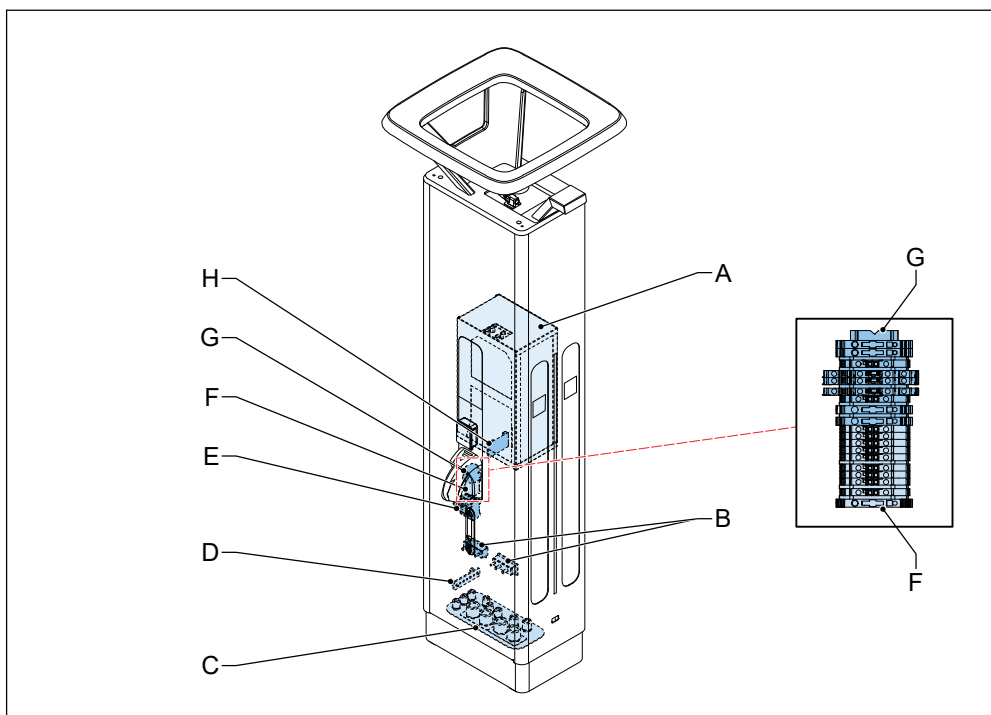

- A Cooling unit
- B DC power busbars
- C Cable gland plates
- D PE busbar
- E Q1 RCD (residual current circuit breaker)
- F X-10 terminal block
- G X-20 terminal block
- H -A4 CAN2ETH device

Part	Function
Cooling unit	To decrease the temperature of the charge cables
DC power busbars	To connect the DC power cables
Cable gland plates	Glands for the cables to the charge post
PE busbar	To connect the PE wire
Q1 RCD	Residual current circuit breaker to connect or disconnect the AC auxiliary power to the charge post
X-10 terminal block	To connect the AC auxiliary power cable
X-20 terminal block	To connect the interlock and DC guard cable
CAN2ETH device	To connect the Ethernet cable

3.5.8 Overview of the cable glands of the charge post

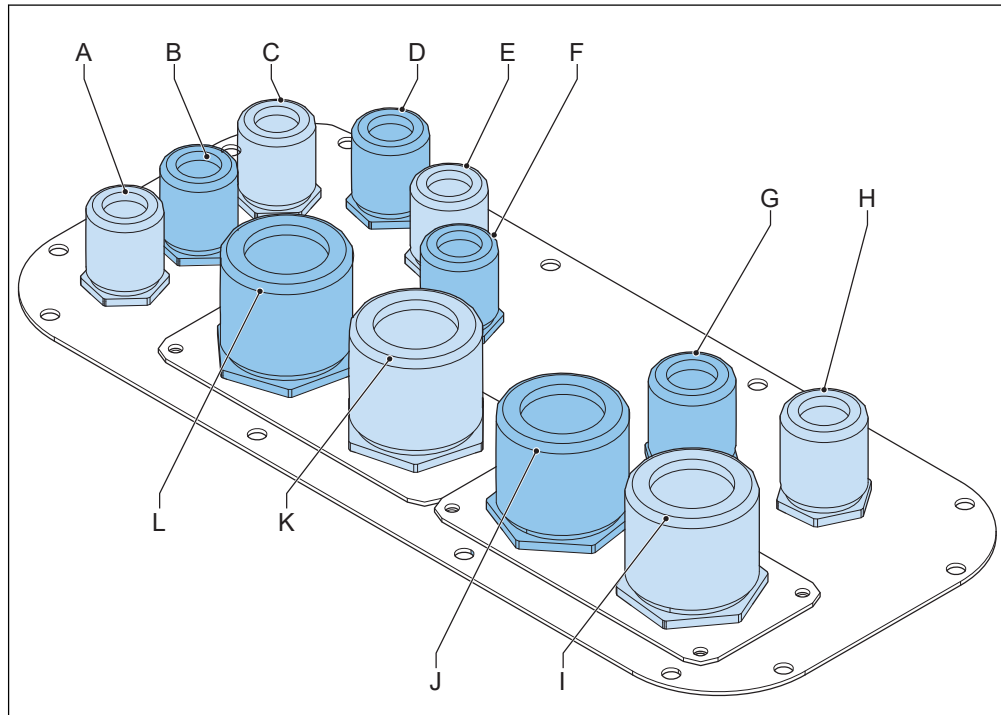

- | | | | |
|---|--------------------------|---|------------------------------|
| A | PE wire | G | Interlock and DC guard cable |
| B | AC auxiliary power cable | H | Ethernet cable |
| C | PE wire | I | DC+ in cable |
| D | PE wire | J | DC+ in cable |
| E | Ethernet cable | K | DC- in cable |
| F | Not used | L | DC- in cable |

3.6 Electric Vehicle Site Solution Control 202 (EVSS)

The EVSS Control 202 basic functionality is the load management of an EV charging site. It is managing the power consumed on a site and enables a centralized OCPP connectivity gateway to the user's or CPO's backend. The EVSS Control 202 contains:

- a Centralized connectivity to operator backend for OCPP traffic;
- Local site power management to manage, distribute and monitor available power/load of the site for each charger;

3.7 Tilt Sensor Supply

The Tilt Sensor Supply is a device to connect all wirings for the emergency circuits described below:

- Connecting circuits to enable LV circuit breaker tripping mechanism during activation of tilt sensors within the Power Cabinets and Charge Posts;
- Enabling the possibility to connect an emergency stop button (EMO);

Maximum twenty-four HP 360 Charger systems and one Terra 53/54 can be connected to one EVSS Control 202 and Tilt Sensor Supply.

3.8 EV charge cable, CCS 2

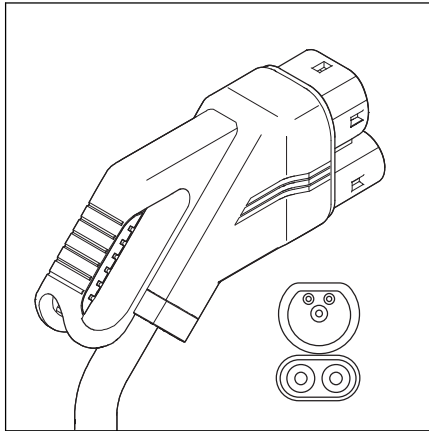

3.9 Parking sensor

The charger is equipped with a parking sensor used for the detection of all passenger cars or larger objects (trucks, containers,...) blocking the parking lot belonging to the Charge Post.



Note: No reaction to smaller objects. People or animals standing on the parking lot, shall only influence the system if standing steady in the specified range where the EV is expected.

3.10 Options

3.10.1 Authorization to charge

It is possible to use the EVSE with or without authorization.

An authorization can be based on RFID, a personal identification number, or a mobile authentication method. Authorization requires a subscription to a back office. Authorization can be a standard solution from the manufacturer, or from an external company that offers authorization solutions via OCPP.

3.10.2 Payment terminal

The touchscreen guides the user how to use the payment terminal.



Note:

- To use and adjust the settings of the payment terminal, you require the ABB Payment Web tool.

3.10.3 Fiscal metering system

The EVSE can optionally be equipped with an MID compliant DC energy meter. This upgrade can be installed in the factory or in the field.

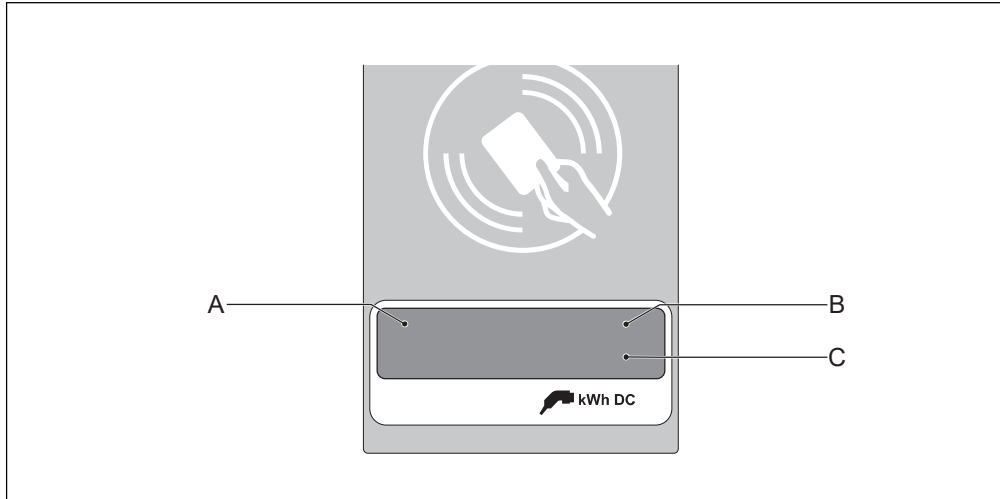

A Time (hh:mm:ss)
B Date (YY-MM-DD)

C Delivered DC power (kWh)



Note: The presence of the MID compliant DC meter is mandatory in some countries. Do a check of the regulations that are applicable in the country of installation.

4 Pre-installation

4.1 Pre-installation procedure (site planning)

Preliminary requirements

	<ul style="list-style-type: none"> All required permits to comply with the local rules, are granted.
---	---

Procedure

- Do a check on the configuration of the EVSE. Refer to the order.
- Refer to the specifications to prepare and order these items:
 - Foundations. Refer to section 12.16.
 - Cable specifications. Refer to section 12.18.
- Make sure that the cable slack for each cable is sufficient to guide the cables in the cabinets. Refer to section 12.14.
- Prepare the EVSE site. Refer to section 4.2.
- Prepare the secondary substation transformer. For the expected wye input, refer to section 12.20.
- Make sure that the floor space for the EVSE and the airflow around the EVSE is correct. Refer to section 4.3.
- Prepare the underground installation:
 - Prepare the cable conduits. For the overview of the cable conduits, refer to section 12.17.
 - Prepare the foundations. Refer to section 4.4.

4.2 Prepare the site

- Make sure that the design of the site complies with these specifications:
 - The length of the charge cables is sufficient for connection to the charge inlet of the EV. For the length and cable reach of the charge cables, refer to section 12.15.2.
 - The maximum distance between the power cabinet and the charge post. Refer to section 12.15.4.
- Create a slope to drain the water away from the EVSE.
- Create a parking space that allows the EV to have easy access to the EV charge cable.
- Apply road signs or markings to indicate that the parking space is intended for EV charge sessions.
- Install barriers or posts around the power cabinet and between the charge post and the parking space.
- Increase the height of the pavement and make sure that it is clearly visible, to prevent damage of the EV.

7. Make sure that the site complies with the relevant usability standards, such as ADA and DIN 18040:
 - a. Limit the curb heights.
 - b. Take into account the limited reach of a wheelchair user.

For usability standards specifications, refer to section 12.14.3.
8. Make the site as safe as possible.
 - a. Make sure that the EVSE can be clearly seen and monitored.
 - b. Apply 24/7 security control.
 - c. Install sufficient lighting.

4.3 Make sure that the floor space for the EVSE and the airflow around the EVSE is correct

1. Make sure that the floor spaces meet the requirements. Refer to section 12.15.
2. Make sure that the air flow inlet and outlet cannot get blocked. Think of snow or objects.

4.4 Prepare the foundation

4.4.1 Prepare the foundation - general procedure



Caution: Make sure that the foundation of the charge post is level. You cannot use shims to level the charge post.

1. Select the correct foundations, based on the underground.
2. Prepare the foundation for the power cabinets.

Type	Procedure
Prefab concrete foundation	Refer to section 4.4.2.
Metal foundation	Refer to section 4.4.3.

3. Prepare the foundation for the charge posts.

Type	Procedure
Prefab concrete foundation	Refer to section 4.4.4.
Metal foundation	Refer to section 4.4.5.
Custom foundation	Refer to section 4.4.6.

4. If you use a concrete foundation, install the grommet plate. Refer to section 4.5.
5. Install the cable support. Refer to section 4.6.

4.4.2 Prepare a prefab concrete foundation for the power cabinet

Preliminary requirements



- Prefab concrete foundation. Refer to section 12.16.1.

Procedure

1. Contact the manufacturer to order the foundation for your EVSE. Refer to section 1.12.
2. Dig the hole for the foundation.



Caution: Make sure that the top surface of the foundation is above the ground level, to prevent intrusion of water.

3. Guide the cable conduits into the cable entries (A) of the foundation.
4. Install the foundation in the hole.
5. Pull the cables through the cable conduits in the foundation. Apply the full cable slack.

For the specification of the cable slack, refer to section 12.14.1.

6. Fill the foundation with gravel or another substance to prevent rodents to enter the cabinet.

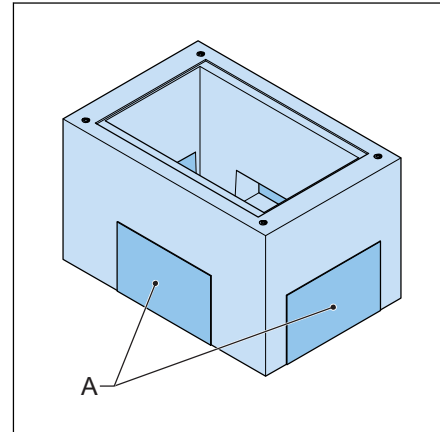

4.4.3

Prepare a metal foundation for the power cabinet

Preliminary requirements

	<ul style="list-style-type: none"> • Drill with screw tap • Torque wrench 		<ul style="list-style-type: none"> • Metal frame. Refer to section 12.16.2. If you have not included the foundation in the initial order, contact the manufacturer to order the foundation for your power cabinet. Refer to section 1.12.
--	---	--	--

Procedure

1. Mark the position of the holes (A) on the floor.
2. Drill and thread the holes. Do not make holes in not authorized locations, because this can compromise the structural integrity of the metal foundation.
3. Guide the cables to the grommet plate (B).
4. Align the metal frame (C) with the threaded holes.
5. Install the fasteners (D) with washers.
6. Tighten the fasteners to the correct torque. For the specification, refer to section 12.13.

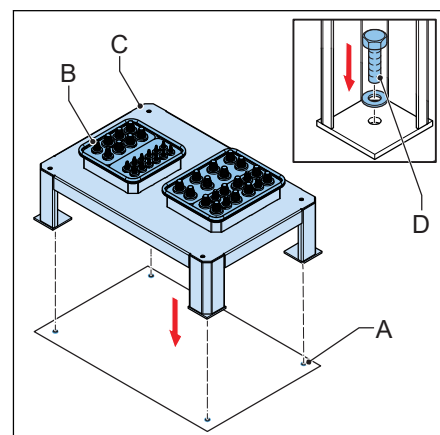

4.4.4

Prepare a prefab concrete foundation for the charge post

Preliminary requirements



- Prefab concrete foundation. Refer to section 12.16.5.

Procedure

1. Contact the manufacturer to order the foundation for your EVSE. Refer to section 1.12.
2. Dig the hole for the foundation.



Caution:

- Make sure that the top surface of the foundation is above the ground level, to prevent intrusion of water.
- Make sure that the orientation of the foundation is correct: X is the left side of the charge post, Y is the front side.

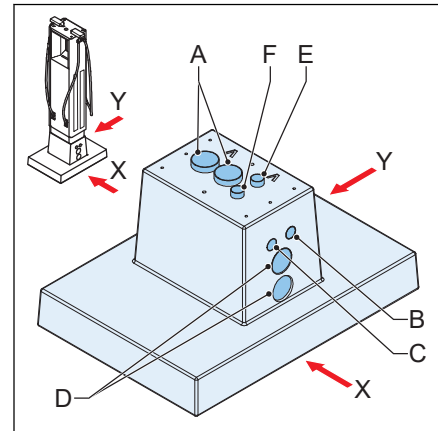



Note: The holes at the side of the foundation are at the left side of the charge post.

3. Guide the cable conduits into the holes of the foundations:
 - Holes (A): exit cable conduit for the DC power cables
 - Holes (B): entrance cable conduit for the Ethernet, interlock and DC guard cables, from the power cabinet
 - Holes (C): entrance cable conduit for the AC auxiliary power and PE cables, from the power cabinet
 - Holes (D): entrance cable conduit for the DC power cables
 - Holes (E): exit cable conduit for the Ethernet, interlock and DC guard cables
 - Holes (F): exit cable conduit for the AC auxiliary power and PE cables
4. Install the foundation in the hole.
5. Pull the cables through the cable conduits in the foundation. Apply the full cable slack.
For the specification of the cable slack, refer to section 12.14.2.
6. Fill the foundation with gravel or another substance to prevent rodents to enter the cabinet.

4.4.5 Prepare a metal foundation for the charge post

Preliminary requirements

	<ul style="list-style-type: none"> • Drill with screw tap • Torque wrench 		<ul style="list-style-type: none"> • Metal frame. Refer to section 12.16.4. If you have not included the foundation in the initial order, contact the manufacturer to order the foundation for your power cabinet. Refer to section 1.12.
---	---	---	--

A metal foundation is suitable if the power cabinet is installed on a solid floor and you need to connect conduit pipes. Make sure that the metal foundation is attached to the equipment enclosures and that the equipment enclosures are mounted to the ground. For an overview and the specifications of the metal frame (A) for the power cabinet, refer to section 12.16.2.

Procedure

1. Mark the position of the holes (B) on the ground. For the specifications, refer to section 12.15.2.
2. Drill and thread the holes. Do not make holes in not authorized locations. This may compromise the structural integrity of the metal foundation.
3. Drill the gland plate to allow the cable conduits to pass through.
 - For an overview of the cable conduits, refer to section 12.15.2.
 - For the gland plates, refer to section 3.5.8.

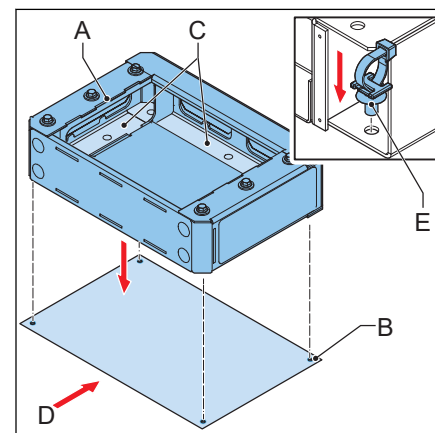

You can insert your own conduit knockouts, based on the shaded regions.

4. Guide the cables to the cable trays (C).
5. Align the metal frame (A) with the threaded holes. Make sure that the front of the metal frame (D) is in the correct position.
6. Install the fasteners (E).
7. Tighten the fasteners to the correct torque. For the specification, refer to section 12.13.

4.4.6 Prepare a custom foundation for the charge post

Preliminary requirements

	<ul style="list-style-type: none"> • Custom foundation. Refer to section 12.16.7.
---	--

Procedure

1. Make the custom foundation.



Caution: Make sure that the top surface of the foundation is above the ground level, to prevent intrusion of water.

2. Guide the cables into the holes (C1) to (C4) of the foundations. For the relation between the cables and the holes, refer to section 12.16.7.
3. Install the foundation in the hole.
4. Put the cables through the openings in the foundation. Apply the full cable slack.

For the cable slack, refer to section 12.14.2.

5. Fill the foundation with gravel or another substance to prevent rodents to enter the cabinet.

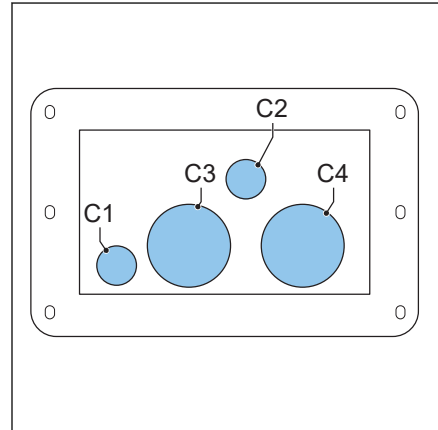

4.5 Install the grommet plate for the concrete foundation of the power cabinet

Preliminary requirements

	<ul style="list-style-type: none"> • Torque wrench 		<ul style="list-style-type: none"> • Grommet plate
--	---	--	---

Procedure

1. Contact the manufacturer to order the grommet plate for your EVSE. Refer to section 1.12.
2. Guide the cables through the grommet plate (A).
3. Pull the cables through the cable conduits in the foundation. Apply the cable slack as per the specification on section 12.14.1.
4. Install the grommet plate on the foundation (B).
5. Install the fasteners (C).
6. Tighten the fasteners to the correct torque. For the specification, refer to section 12.13.
7. Strip the insulation from the end of the cables. Make sure that the stripped length is compatible with the cable lug specification.
8. Install the cable lug to the end of the cables.

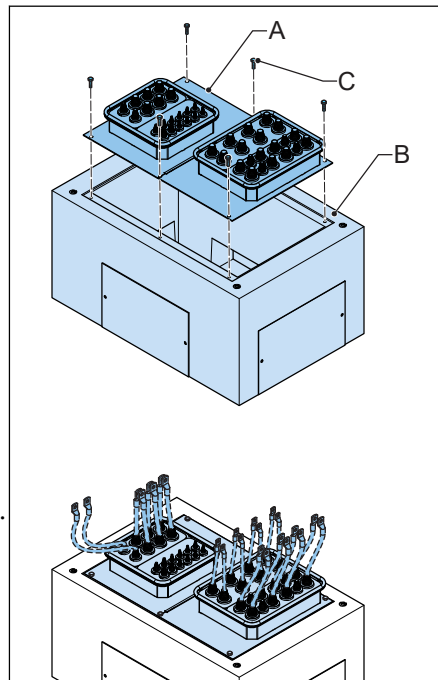

5 Inspection and transport

5.1 Transport the EVSE to the site

A transport company delivers the EVSE close to the site. The movement of the EVSE to its final location is your responsibility.

- If you need to store the EVSE before installation, obey the ambient conditions for storage. Refer to section 12.11.

5.2 Inspect the EVSE on delivery

1. Do a check on the transport sensors. Refer to section 5.3.
2. Unpack the EVSE. Refer to section 5.4.
3. Do a check if the EVSE is in accordance with the order.
4. Do a check on the EVSE for damage.
5. If the EVSE shows damage or is not in accordance with the order, tell the transport company immediately.

5.3 Do a check on the transport sensors

1. Do a check on the sensors (A) that record the shocks during transport.
2. Do a check on the sensors (B) that record the maximum tilt during transport.
3. If the sensors (A) show a red indication or the sensors (B) show a tilt that is too high, do these steps:
 - a. Refuse the delivery of the EVSE.
 - b. Make a note on the delivery receipt.
 - c. Within three days of the delivery, ask the transport company for an inspection.
- d. If you see damage on the cabinet, through the packaging material, do not unpack the EVSE.
- e. Contact the manufacturer and give details of the delivery problems. Refer to section 1.12.

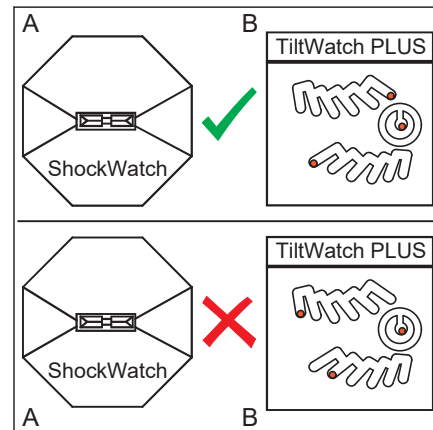

5.4 Unpack the EVSE

1. Remove the packaging material.
2. Discard the packaging material. Refer to section 2.9.
3. Remove the cabinet from the pallet. Refer to section 5.5.

5.5 Remove the cabinet from the pallet

Preliminary requirements

	<ul style="list-style-type: none"> • Open spanner
---	--

Procedure

1. Remove the fasteners (A).
2. Discard the fasteners and the pallet.
Refer to section 2.9.

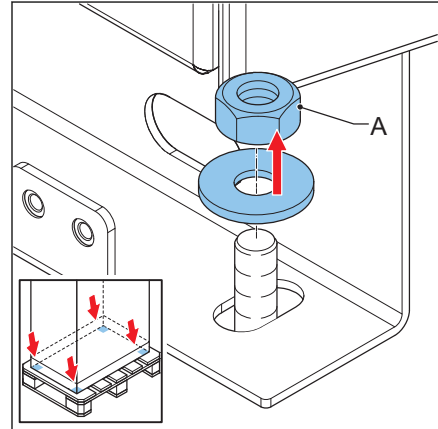

5.6 Transport the EVSE on the site

5.6.1 General transport procedure

Preliminary requirements

	<ul style="list-style-type: none"> • The cabinets are unpacked. Refer to section 5.4.
---	--



Note: The charge post is delivered horizontally or vertically.



Caution: Do not tilt the power cabinet to the horizontal position. In the horizontal position, the power cabinet breaks.

Procedure



1. Move the power cabinet to the installation location:
 - Move the cabinet with a forklift truck. Refer to section 5.6.3.
 - Hoist the cabinet. Refer to section 5.6.4.
2. Move the charge post to the installation location:

Situation	Procedure
Tilt the charge post to the vertical position.	Refer to section 5.6.2.
Move the charge post with a forklift truck.	Refer to section 5.6.3.
Hoist the charge post.	Refer to section 5.6.4.

5.6.2

Tilt the charge post to the vertical position

Preliminary requirements

	<ul style="list-style-type: none"> • The charge post is in the horizontal position. • The charge post is unpacked. Refer to section 5.4. 		<ul style="list-style-type: none"> • Hoisting equipment, including cables, swivel eye bolts or bolts with lifting loops. Refer to section 12.3.
---	--	---	--



Warning:

Risk of pinching or crushing, the charge post is heavy

- Make sure that the hoisting equipment can lift the charge post safely. Obey the safety instructions that apply to the hoisting equipment. Take into account the dimensions, the mass and the center of gravity of the charge post. Refer to chapter 12.



Caution:

- Do not drop the charge post. There is a risk of damage.

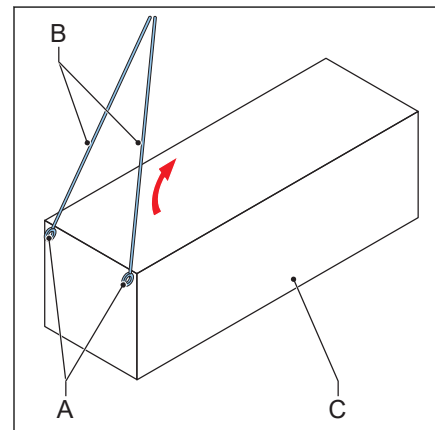

Procedure

1. Install the swivel eye bolts or bolts with lifting loops (A).
2. Connect the hoisting equipment (B).
3. Carefully tilt the charge post (C) to the vertical position.
4. Remove the swivel eye bolts or bolts with lifting loops (A).



5.6.3 Move the cabinet with a forklift truck

Preliminary requirements

	<ul style="list-style-type: none"> The cabinet is unpacked. Refer to section 5.4. 		<ul style="list-style-type: none"> Forklift truck. Refer to section 12.3.
---	--	--	--



Warning:

Risk of pinching or crushing, the cabinet is heavy

- Make sure that the forklift truck can lift the cabinet safely. Obey the safety instructions that apply to the forklift truck. Take into account the mass, the dimensions and the center of gravity of the EVSE. Refer to sections 12.10 and 12.14.



Caution: Do not drop the cabinet.

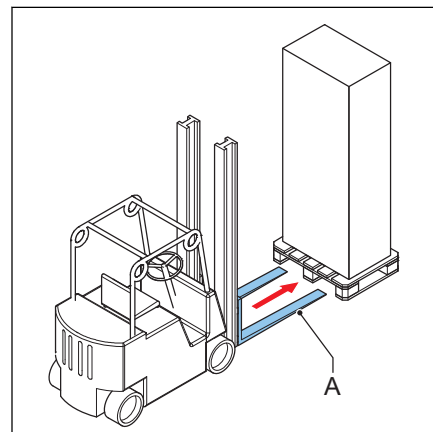

Procedure

1. Move the forks (A) of the forklift truck in the gaps at the side of the cabinet.
2. Move the cabinet to the correct location.



5.6.4 Hoist the cabinet

Preliminary requirements

	<ul style="list-style-type: none"> The cabinet is unpacked. Refer to section 5.4. 		<ul style="list-style-type: none"> Hoisting equipment, including cables (not chains), swivel eye bolts or bolts with lifting loops. Refer to section 12.3.
---	--	--	---



Warning:

Risk of pinching or crushing, the cabinet is heavy

- Make sure that the hoisting equipment can lift the cabinet safely. Obey the safety instructions that apply to the hoisting equipment. Take into account the dimensions, the mass and the center of gravity of the EVSE. Refer to sections 12.10 and 12.14.



Caution:

- Do not drop the cabinet.
- Make sure that there are no dynamic forces on the hoisting points.
- Make sure that the weight is equally distributed between the hoisting points.

Procedure

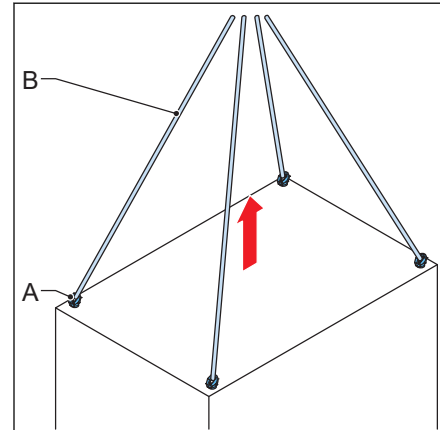

1. Install the swivel eye bolts or bolts with lifting loops (A).
2. Connect the cables (B) of the hoisting equipment to the swivel eye bolts or bolts with lifting loops.
3. Move the cabinet to the correct location.
4. Remove the swivel eye bolts or bolts with lifting loops (A).
5. Install the plastic cover on the threaded location.



6 Installation

6.1 General installation procedure

Preliminary requirements

	<ul style="list-style-type: none"> The AC input cable is available. The foundations for the cabinets are prepared. All cables are in the cable entries or the grommet plate and the full cable slack is applied. The distribution board is prepared. The site is prepared and has no obstacles that can trigger the parking sensor. 		<ul style="list-style-type: none"> There is no voltage on the AC input cable during the complete installation procedure.
	<ul style="list-style-type: none"> Tools for installation. Refer to section 12.3. 		

Procedure

1. Do the mechanical installation of the power cabinet. Refer to section 6.2.
2. Do the mechanical installation of the charge post. Refer to section 6.3.
3. Do the electrical installation of the power cabinet. Refer to section 7.
4. Do the electrical installation of the charge post. Refer to section 8.
5. Prepare for commissioning. Refer to section 9.

6.2 Mechanical installation of the power cabinet

6.2.1 Install the power cabinet - general procedure

Preliminary requirements

	<ul style="list-style-type: none"> The cabinet is above the foundation.
---	--

Procedure

1. Remove the plinth covers of the power cabinet. Refer to section 10.2.
2. Remove the cable support. Refer to section 6.2.2.
3. Install the cabinet on the foundation. Refer to section 6.2.3.
4. Install these parts:
 - a. Cover plate of the metal foundation. Refer to section 6.2.4.
 - b. Plinth covers of the power cabinet.
5. Replace the eye bolts on the power cabinet with the caps. Refer to section 12.2.

6.2.2 Install the cabinet on the foundation

Preliminary requirements

	<ul style="list-style-type: none"> • Hoisting equipment or forklift truck • Torque wrench 		<ul style="list-style-type: none"> • Four fasteners M16 and washers
---	---	---	--

Procedure

1. Carefully lower the cabinet on the foundation with a hoisting equipment or a forklift truck. Refer to section 5.6.1.



Caution: Make sure that there is no kink in the cables.

2. Make sure that the holes in the cabinet (A) and the foundation (B) are aligned.



Caution: Only use three fasteners when the power cabinet is installed in an array of 2 x n.

3. Install the fasteners (C) and the washers.
4. Tighten the fasteners to the correct torque. For the specification, refer to section 12.13.

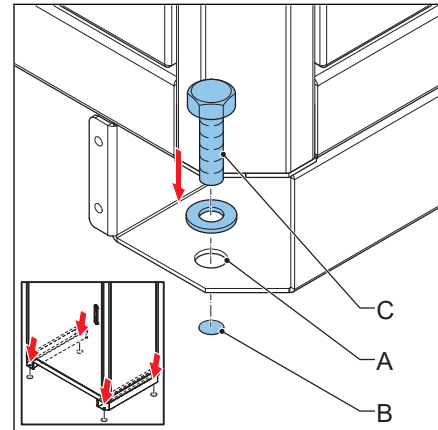

6.2.3 Install the cover plates of the metal foundation

Preliminary requirements

	<ul style="list-style-type: none"> • The cabinet is installed on the foundation. 		<ul style="list-style-type: none"> • 16 fasteners M6 (included in the foundation kit)
---	---	---	--

Procedure

1. Install the cover plates (A).
2. Install the fasteners (B).
3. Tighten the fasteners to the correct torque. For the specification, refer to section 12.13.

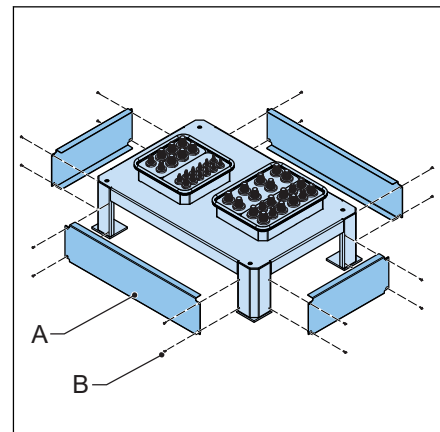

6.3 Mechanical installation of the charge post

6.3.1 Install the charge post - general procedure

Preliminary requirements

	<ul style="list-style-type: none"> The charge post is above the foundation.
---	--



Warning: Make sure that you secure the load when you do work below the charge post. Obey all related local regulations.



Note: The manufacturer installed the cooling unit at the factory, including the cooling liquid.

Procedure

1. Get access to the charge post:
 - a. Remove the plinth covers of the charge post. Refer to section 10.7.
 - b. Open the door of the charge post. Refer to section 10.6.
 - c. Remove the protection plate of the charge post. Refer to section 10.8.
2. Remove the cable gland plates. Refer to section 6.3.2.
3. Guide the cables through the cable glands. Apply the full cable slack. Refer to section 12.14.2.
4. Install the charge post on the foundation. Refer to section 6.3.3.
5. Install the cable gland plates. Refer to section 6.3.4
6. Close the charge post:
 - a. Install the protection plate of the charge post.
 - b. Close and lock the door of the charge post.
 - c. Install the plinth covers of the charge post.
7. Replace the eye bolts on the charge post with the caps. Refer to section 12.2.

6.3.2 Remove the cable gland plates

Preliminary requirements

	<ul style="list-style-type: none"> The door is open. The protection cover is removed. 		<ul style="list-style-type: none"> Screwdriver, cross Set of open spanners
---	---	---	--

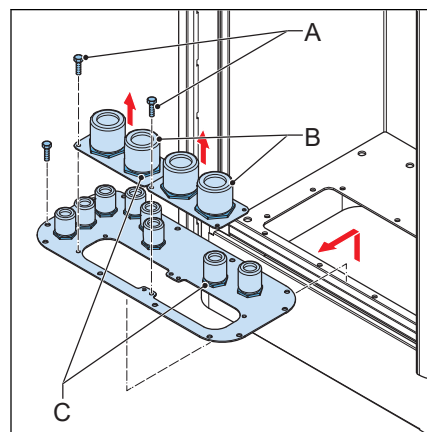

Procedure

1. Remove these parts:
 - a. Fasteners (A)
 - b. Cable gland plates (B)
 - c. Nuts (C) of the cable glands



6.3.3 Install the charge post on the foundation

Preliminary requirements

	<ul style="list-style-type: none"> • Hoisting equipment or forklift truck • Torque wrench 		<ul style="list-style-type: none"> • Six fasteners M12 and washers • Drop in anchors, for easy installation and quality
---	---	---	---

Procedure

1. Carefully lower the charge post on the foundation with a hoisting equipment or a forklift truck. Refer to section 5.6.1.



Caution: Make sure that there is no kink in the cables.

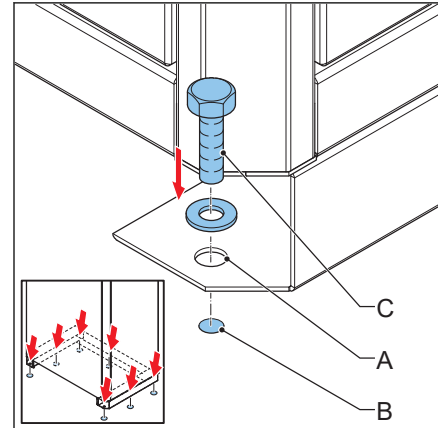

2. Make sure that the holes in the charge post (A) and the foundation (B) are aligned.
3. Install the fasteners (C) and the washers.



4. Tighten the fasteners to the correct torque. For the specification, refer to section 12.13.

6.3.4 Install the cable gland plates

Preliminary requirements

	<ul style="list-style-type: none"> • The door is open. • The protection cover is removed. 		<ul style="list-style-type: none"> • Screwdriver, cross • Set of open spanners
---	---	---	--

Procedure

1. Install the nuts (A) of the cable glands over the cables.
2. Install these parts:
 - a. Cable gland plates (B)
 - b. Fasteners (C)
3. Tighten the nuts of the cable glands.

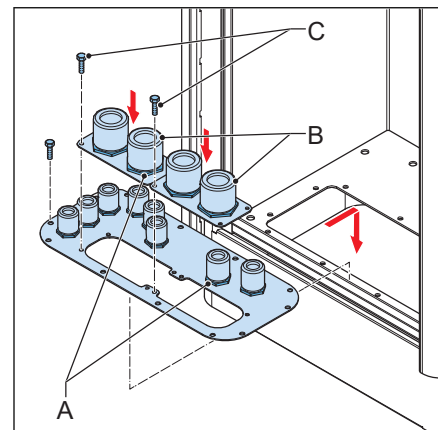

7 Electrical installation of the power cabinet

7.1 General procedure



Note: For a detailed overview of all electrical connections, refer to section 12.19.

Preliminary requirements

	<ul style="list-style-type: none"> The DC cables are installed in one of the cable conduits. Refer to section 12.17. The AC input cable, the PE wire and the communication cables are installed in the other cable conduits. Refer to section 12.17. 		<ul style="list-style-type: none">
--	--	--	--

Procedure

- Open the door of the power cabinet. Refer to section 10.1.
- Connect the PE wires to the power cabinet. Refer to section 7.2.
- Connect the AC input cable.
 - Remove the AC cover. Refer to section 10.4.
 - Connect the AC input cable. Refer to section 7.3.
 - Install the AC cover.
- Connect the AC auxiliary power, interlock and DC guard, and Ethernet cables.
 - Connect the AC auxiliary power cable. Refer to section 7.4.
 - Connect the interlock and DC guard cables. Refer to section 7.5.
 - Connect the Ethernet cable. Refer to section 7.6.
- Close and lock the door of the power cabinet. Refer to section 10.5.

7.2 Connect the PE cable

Preliminary requirements

	<ul style="list-style-type: none"> Wire stripper pliers Wire cutter Torque wrench 		<ul style="list-style-type: none">
	<ul style="list-style-type: none"> Cable lug Fasteners M11 		

Procedure

1. Attach the PE cable (A) to the PE busbar (B) with a loop. Use the fasteners (D). The loop is necessary to make sure that the PE cable is not the first wire that is disconnected when a collision moves the charge post.
2. Tighten the fasteners to the correct torque. For the specification, refer to section 12.13.

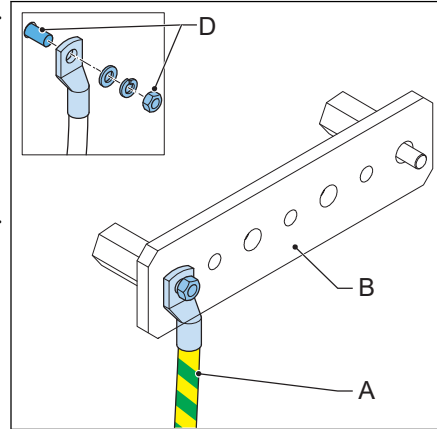

7.3

Connect the AC power cables in the power cabinet

Preliminary requirements

	<ul style="list-style-type: none"> • Wire stripper pliers • Wire cutter • Torque wrench 		
	<ul style="list-style-type: none"> • Cable lug • Fasteners M11 		



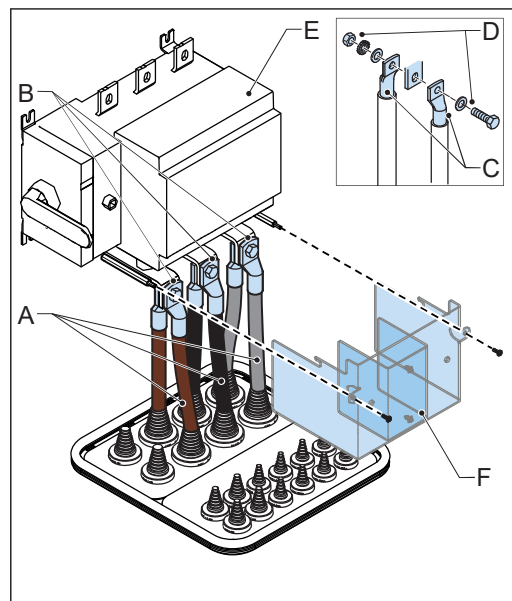

Procedure

1. Attach the AC cables to the AC busbars. Use the fasteners (D).
2. Tighten the fasteners to the correct torque. For the specification, refer to section 12.13.
3. Reinstall the protective cover (F) by screwing the 2 fasteners.



7.4 Connect the DC power cable in the power cabinet

Preliminary requirements

	<ul style="list-style-type: none"> • Wire stripper pliers • Wire cutter • Torque wrench 		
	<ul style="list-style-type: none"> • Cable lug • Fasteners M11 		

Procedure

1. Prepare the DC+ cables:
 - a. Cut the DC+ cables (A) to make sure that the length is sufficient for connection at the DC+ terminal block (C).
 - b. Strip the insulation from the end of the cables. Make sure that the stripped length is compatible with the cable lug specification.
 - c. Attach the cable lug to the end of the wires.
2. Attach the DC+ cables to the DC+ terminal block (C). Use the fasteners (B).

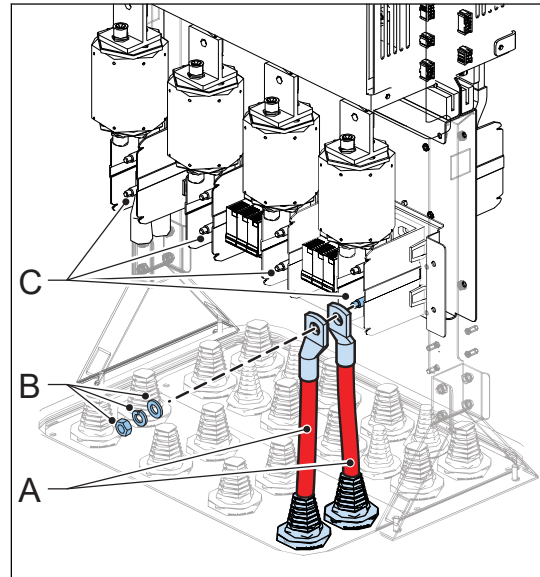



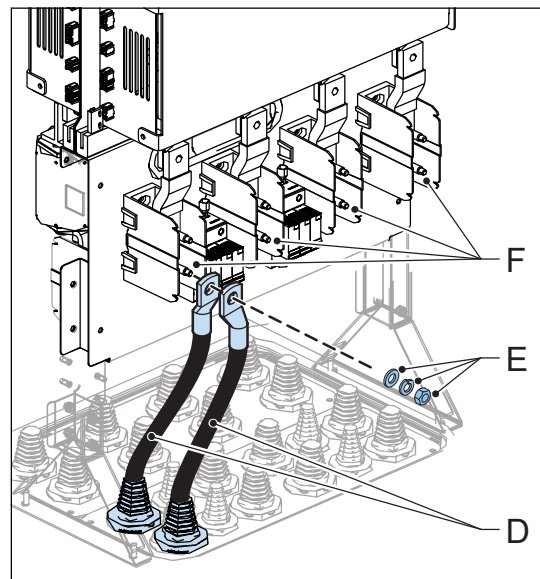

1. Prepare the DC- cables:
 - a. Cut the DC- cables (D) to make sure that the length is sufficient for connection at the DC- terminal block (F).
 - b. Strip the insulation from the end of the cables. Make sure that the stripped length is compatible with the cable lug specification.
 - c. Attach the cable lug to the end of the wires.
2. Attach the DC- cables to the DC- terminal block (F). Use the fasteners (E).



7.5 Connect the AC auxiliary cable in the power cabinet

Preliminary requirements

	<ul style="list-style-type: none"> • Torque screwdriver, cross • Wire cutter • Wire stripper pliers • Crimp pliers 		<ul style="list-style-type: none"> • 
	<ul style="list-style-type: none"> • AC auxiliary power cable. Refer to section 12.18.4. • Ferrules 		



Note: The AC auxiliary power cable provides the control power to the charge post.

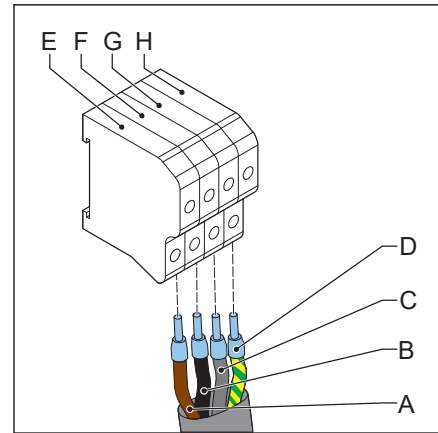

Procedure

- Strip the insulation from the ends of the wires (A) to (D).
 - For the procedure, refer to section 11.2.
 - For the specification, refer to section 12.18.4.
- Crimp ferrules onto the end of the wires. Refer to section 11.2. Obey the ferrule manufacturer recommendations.
- Loosen the screws of the terminal block X-3.
- Connect these wires:
 - L1 wire (A), brown, to the terminal X3-1 (E)
 - L2 wire (B), black, to the terminal X3-2 (F)
 - L3 wire (C), gray, to the terminal X3-3 (G)
 - PE wire (D), green/yellow, to the terminal X3-4 (H)
- Tighten the screws to the correct torque. For the specification, refer to section 12.13.



7.6 Connect the interlock and DC guard cables to the power cabinet

Preliminary requirements

	<ul style="list-style-type: none"> Interlock and DC guard cable. Refer to section 12.18.5. 		
---	---	--	---



Note: The illustration shows the terminal block X9 on the power cabinet and the connections treated in this section. For a detailed overview of all electrical connections, refer to section 12.19.

Procedure

1. Prepare ferrules for the wires that are mentioned below. Refer to section 11.2.

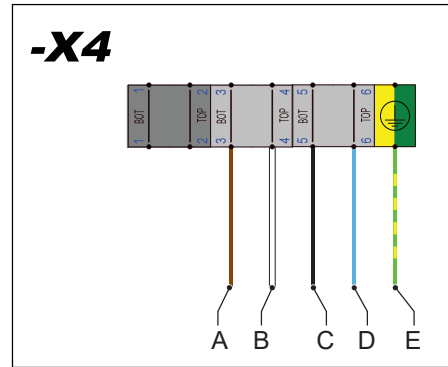

2. Connect the below listed wires from the charge post. Use the illustration above as a reference:

Wire from charge post	Connect to terminal	Terminal name
(A) Interlock OUT	X4-3	IN CL CP1
(B) Interlock IN	X4-4	OUT CL CP1
(C) DC guard GND	X4-5	DC1 GUARD
(D) DC guard signal	X4-6	DC1 GUARD RTN
(E) Ground wire or shield mesh	Earthing terminal	DC1 PE

7.7

Connect the Ethernet cable to the power cabinet

Preliminary requirements



- Ethernet cable with an RJ45 plug. Refer to section 12.18.7

Procedure

1. Guide the cable to the Ethernet connector (A)
2. Connect the RJ45 plug to the Ethernet connector.

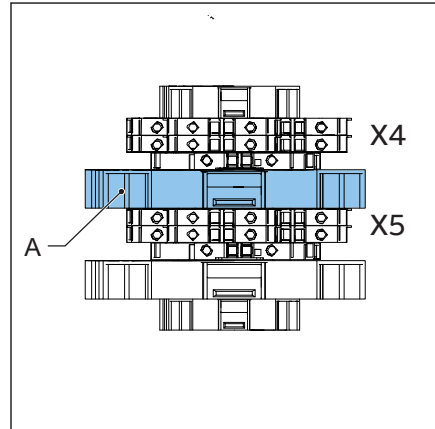

8 Electrical installation of the charge post

8.1 General procedure



Note: For a detailed overview of all electrical connections, refer to section 12.19.

Preliminary requirements

	<ul style="list-style-type: none"> The DC power cables are installed in one of the cable conduits. Refer to section 12.17. The other cables are installed in the other cable conduits. Refer to section 12.17. 		<ul style="list-style-type: none">
--	--	--	---

Procedure

1. Open the door of the charge post. Refer to section 10.6.
2. Remove the protection plate. Refer to section 10.8.
3. Connect the cables to the charge post:
 - PE wires. Refer to section 8.2
 - DC power cable. Refer to section 8.3
 - AC auxiliary power cable. Refer to section 8.4.
 - Interlock and DC guard cable. Refer to section 8.5
4. Install the protection plate.
5. Close and lock the door of the charge post. Refer to section 10.11.

8.2 Connect the PE cable

Preliminary requirements

	<ul style="list-style-type: none"> The door is open. 		<ul style="list-style-type: none"> Cable lug. Refer to section 12.4. Fasteners M11. Refer to section 12.4.
	<ul style="list-style-type: none"> Wire stripper pliers Torque socket wrench 		<ul style="list-style-type: none">

Procedure for each PE connection:



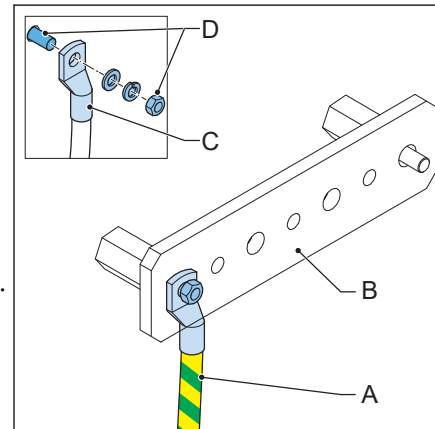

1. Prepare the wire:
 - a. Cut the PE wire (A) to make sure that the length is sufficient for connection at the PE busbar (B) with a loop.
The loop is necessary to make sure that the PE wire is not the first wire that is disconnected when a collision moves the charge post.

- b. Strip the insulation from the end of the wire. Make sure that the strip length is compatible with the cable lug.
 - c. Attach the cable lug (C) to the end of the wire.
2. Attach the PE wire to the PE busbar. Use the fasteners (D).
 3. Tighten the fasteners to the correct torque. For the specification, refer to section 12.13.



8.3 Connect the DC power input cables

Preliminary requirements

	<ul style="list-style-type: none"> • Wire cutter • Wire stripper pliers • Spanner • Torque wrench • Torque screwdriver, cross 	 	<ul style="list-style-type: none"> • 
	<ul style="list-style-type: none"> • DC power cable. Refer to section 12.18.2. • Cable lugs. Refer to section 12.4. 		



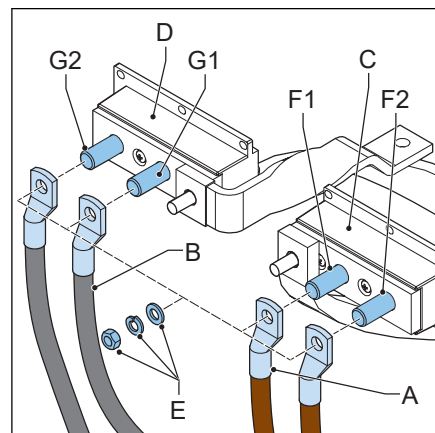

Procedure

1. Cut the DC power cables (A) and (B) to make sure that the length is sufficient for connection at the DC busbars (C) and (D).
2. Strip the insulation from the end of the cables. Make sure that the strip length is compatible with the cable lugs.
3. Attach the cable lugs to the end of the cables.
4. Remove the nuts and washers (E) from the connector bolts (F1) and (G1) of the DC busbars.
5. Connect these cables:
 - DC+ cable (A) to the connector bolt (F1).
 - DC- cable (B) to the connector bolt (G1).
6. If you need to connect more DC cables, do steps 4 and 5 again for the other wires and connector bolts (F2) and (G2).
7. Install the nuts and washers on the connector bolts of the DC busbars.
8. Tighten the nuts to the correct torque. For the specification, refer to section 12.13.



8.4 Connect the AC auxiliary power cable

Preliminary requirements

	<ul style="list-style-type: none"> • Wire cutter • Wire stripper pliers • Torque screwdriver, cross • Crimp pliers 		<ul style="list-style-type: none"> • 
	<ul style="list-style-type: none"> • AC auxiliary power cable • Ferrules 		



Note: The AC auxiliary power cable provides the control power to the charge post.

Procedure

1. Strip the insulation from the ends of the wires (A) to (D). For the specification, refer to section 11.2.
2. Crimp ferrules onto the end of the wires.
3. Loosen the screws of the terminals (E) to (H) of the terminal block X-10.
4. Connect these wires:
 - PE wire (A), green/yellow, to the terminal X10-1 (E)
 - L1 wire (B), brown, to the terminal X10-2 (F)
 - L2 wire (C), black, to the terminal X10-3 (G)
 - L3 wire (D), gray, to the terminal X10-4 (H)
5. Tighten the screws to the correct torque. For the specification, refer to section 12.13.

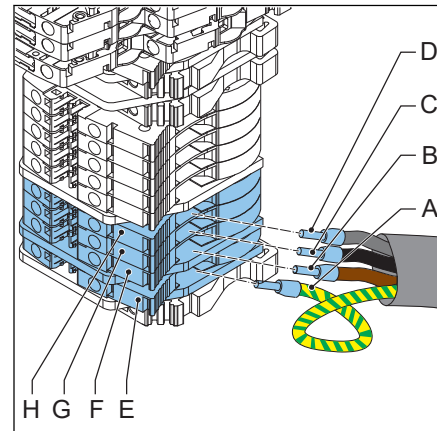





8.5 Connect the interlock and DC guard cable



Note: For a detailed overview of all electrical connections, refer to section 12.19.

Preliminary requirements

	<ul style="list-style-type: none"> • Torque screwdriver, cross 		<ul style="list-style-type: none"> • 
	<ul style="list-style-type: none"> • Interlock and DC guard cable. Refer to section 12.18.5. • Ferrules 		

Electrical installation of the charge post

Procedure

1. Prepare ferrules for the wires that are mentioned below. Refer to section 11.2.

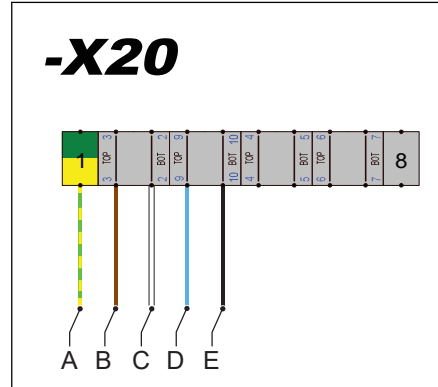

2. Connect these wires from the power cabinet:

Wires from the power cabinet	Connect to terminal	Terminal name
(A) Ground wire or shield mesh	X20-1	PE
(B) IL IN 1	X20-2	Interlock OUT
(C) IL OUT 1	X20-3	Interlock IN
(D) DC guard A1	X20-9	DC guard signal
(E) DC guard A1 RTN	X20-10	DC guard GND



Note: The colors of the cables can be different in your equipment. The colors in the illustration are used to clarify the explanation and to distinguish the different cables.

8.6 Connect the Ethernet cable to the power cabinet

Preliminary requirements



- Ethernet cable with an RJ45 plug. Refer to section 12.18.7

Procedure



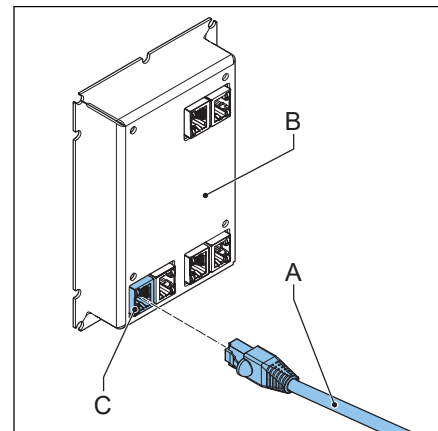

1. Guide the cable (A) to the CAN2ETH board (B).
2. Connect the RJ45 plug to the terminal J1 (C).



8.7 Pre-commissioning mode

If it is not possible to complete commissioning because it is not possible to supply the power cabinet from the main power line, it is necessary to set the charger in "precommissioning mode". In this way it is possible to avoid condensation phenomena inside the charger.

Preliminary requirements

	<ul style="list-style-type: none"> • Torque screwdriver, cross • Wire cutter • Wire stripper pliers • Crimp pliers 		<ul style="list-style-type: none"> • 
	<ul style="list-style-type: none"> • AC single-phase cable. Refer to section 12.18.4. • Ferrules 		

Procedure

- Strip the insulation from the ends of the wires (A) to (C).
 - For the procedure, refer to section 11.2.
 - For the specification, refer to section 12.18.4.
- Crimp ferrules onto the end of the wires. Refer to section 11.2. Obey the ferrule manufacturer recommendations.
- Loosen the screws of the terminal block X-1.
- Connect these wires:

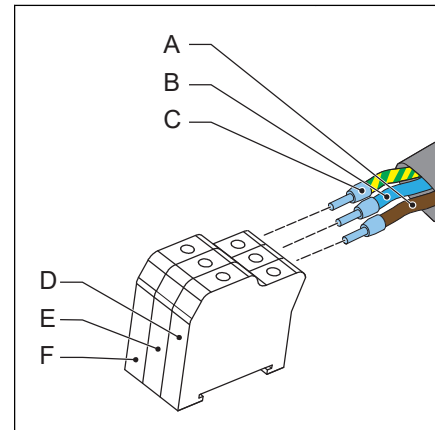

- Line wire (A), brown, to the terminal X1-1 (D)
 - Neutral wire (B), blue, to the terminal X1-2 (E)
 - PE wire (C), green/yellow, to the terminal X1-3 (F)
- Tighten the screws to the correct torque. For the specification, refer to section 12.13.
 - Turn on the switch Q1 of the charge post
 - Turn on the switches Q2, Q3 and Q4 of the power cabinet
 - Set the precommissioning selector on the position 1 (EXT)

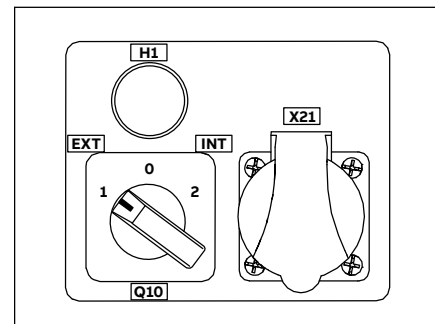

9 Prepare for commissioning

Preliminary requirements

	<ul style="list-style-type: none">
	Installation engineer



Danger:

Hazardous voltage

- Do not commission the EVSE. Only a service engineer of the manufacturer is qualified to commission the EVSE.

Procedure

1. Tell the owner that the EVSE is ready for commissioning.
2. Make sure that the site complies with these requirements:
 - The EVSE is installed.
 - AC input power is available from the grid provider.
 - You are present during the commissioning, for assistance and to energize the power to the EVSE on the power distribution board.
 - Internet access is available, through 2G/3G/4G or through a wired Ethernet connection.
 - An EV must be available with a compatible connection. If the EVSE has more than one connection type, an EV of each type must be available.
 - The site operator or owner is available to receive instructions from the service engineer of the manufacturer.
3. Make sure that this data is available:
 - Contact data of the contact person on site
 - Address of the EVSE
 - Site name
 - Exact location of the EVSE: longitude and latitude. If there are more EVSEs on one location, make sure that the coordinates are slightly different (at least 0.0001 degree) so that the EVSEs are not at the same location on the map.
 - Specification of the external fuse at the power distribution board
 - Date that the installation is done
 - Special remarks, for example to decline the authorization for the service engineer of the manufacturer to take photos
 - Photo of the surroundings of the EVSE

10 Access to parts

10.1 Open the door of the power cabinet

Preliminary requirements



- Door key of the power cabinet



Danger:

Hazardous voltage

- Make sure that only qualified personnel has access to the door key.



Note: There is one unique door key for each power cabinet.

Procedure

1. Turn the cover plate (A).
2. Insert the door key (B).
3. Turn the door key counterclockwise to unlock the door (C).
4. Pull the handle (D).
5. Turn the handle clockwise.
6. Open the door.

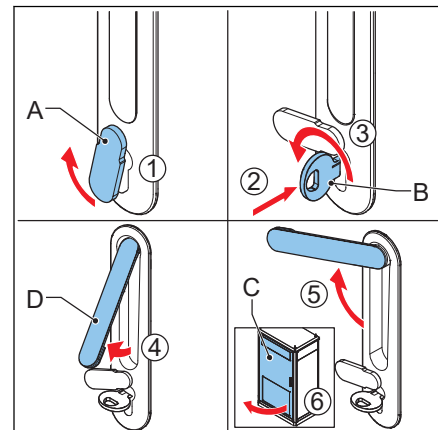

10.2 Remove the plinth covers of the power cabinet

Preliminary requirements



- Set of open spanners

Procedure

1. Remove these parts:
 - Fasteners (A)
 - Plinth covers (B)

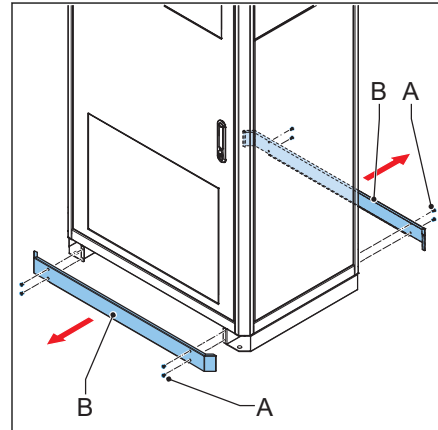

10.3

Open the DC door

Preliminary requirements



- Door key of the DC door



Danger:

Hazardous voltage

- Make sure that only qualified personnel has access to the door key.

Procedure

1. Insert the door key in the lock (A).
2. Turn the door key counterclockwise to unlock the door (B).
3. Do step 1 and 2 again for the second lock (C).
4. Open the door.

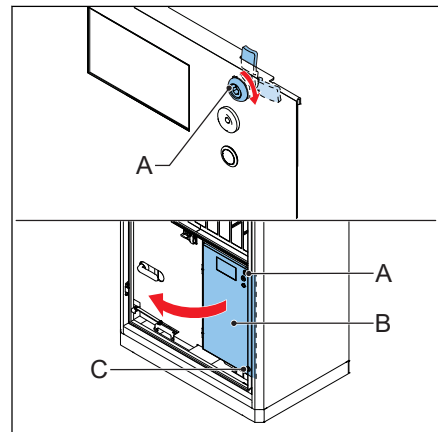

10.4

Remove the AC cover

Preliminary requirements



- Screwdriver

Procedure

1. Set the main switch to off.
2. Remove the fasteners (A).
3. Remove the AC cover (B).

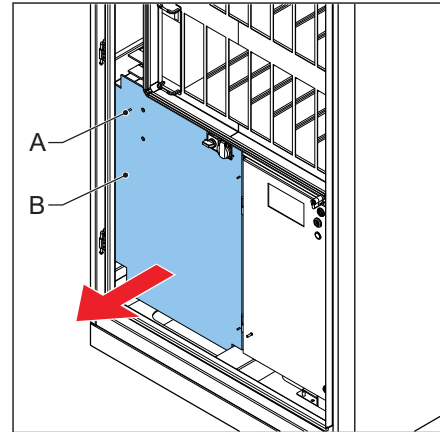

10.5

Close the door of the power cabinet

Preliminary requirements



- Door key to the power cabinet.

**Danger:****Hazardous voltage**

- Make sure that only qualified personnel has access to the door key.



Note: There is one unique door key for each cabinet.

Procedure

1. Close the door (A).
2. Turn the handle (B) counterclockwise.
3. Push the handle.
4. Turn the door key (C) clockwise to lock the door.
5. Remove the door key (C).
6. Turn the cover plate (D) to cover the keyhole.

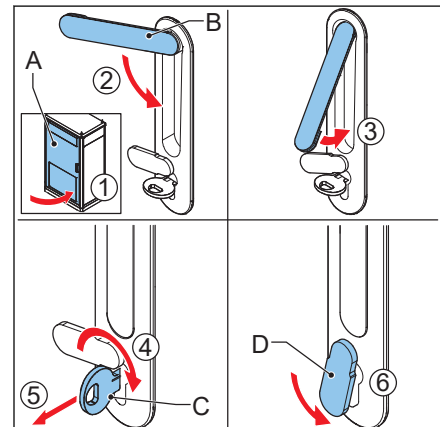

10.6 Open the door of the charge post

Preliminary requirements

	<ul style="list-style-type: none">• Door key of the charge post
---	---



Danger:

Hazardous voltage

- Make sure that only qualified personnel has access to the door key.



Note:

- There is one unique door key for each charge post.
- The door of the charge post is under some pressure, to make sure that it closes watertight.

Procedure

1. Insert the door key (A).
2. Turn the door key counterclockwise to unlock the door (B).
3. Pull the handle (C).
4. Turn the handle clockwise.
5. Open the door.

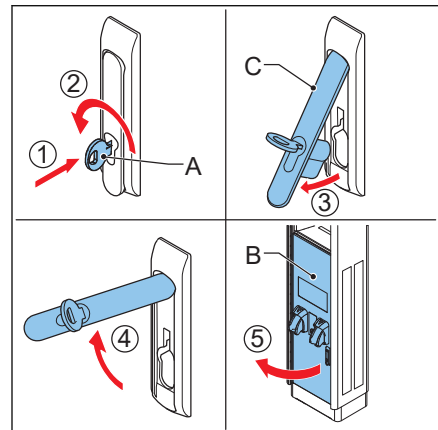

10.7 Remove the plinth covers of the charge post

Preliminary requirements

	<ul style="list-style-type: none">• Set of hex keys
---	---

Procedure

1. Remove these parts:
 - Fasteners (A)
 - Plinth covers (B)

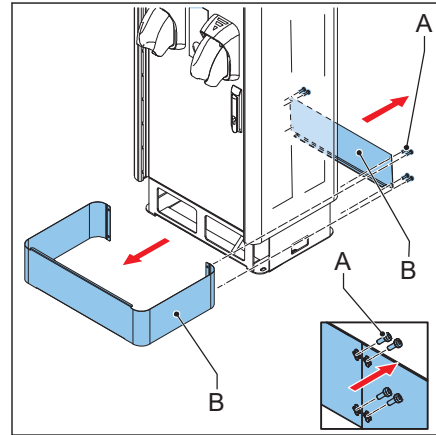

10.8

Remove the protection plate of the charge post

Preliminary requirements



- Screwdriver, cross

Procedure

1. Remove these parts:
 - Fasteners (A)
 - Protection plate (B)

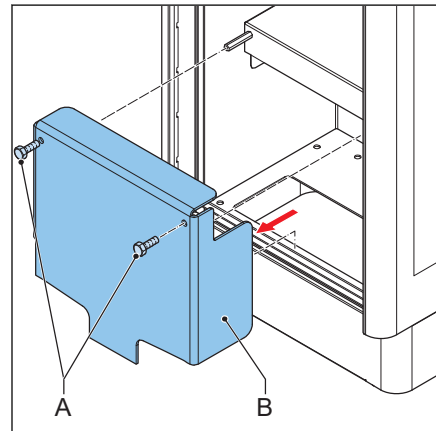

10.9

Install the AC cover

Preliminary requirements



- Screwdriver

Procedure

1. Install the AC cover (A).
2. Install the fasteners (B).
3. Set the main switch to on.

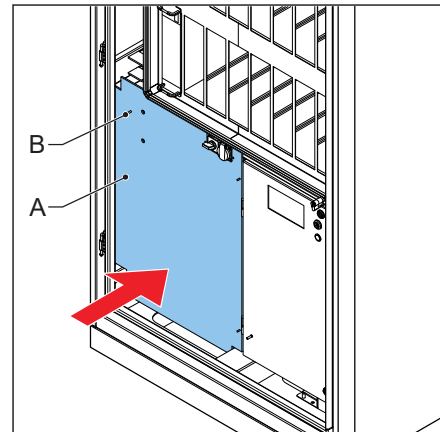

10.10 Close the DC door

Preliminary requirements



- Door key of the DC door



Danger:

Hazardous voltage

- Make sure that only qualified personnel has access to the door key.

Procedure

1. Close the door.
2. Insert the door key in the lock (A).
3. Turn the door key counterclockwise to lock the door (B).
4. Do step 2 and 3 again for the second lock (C).

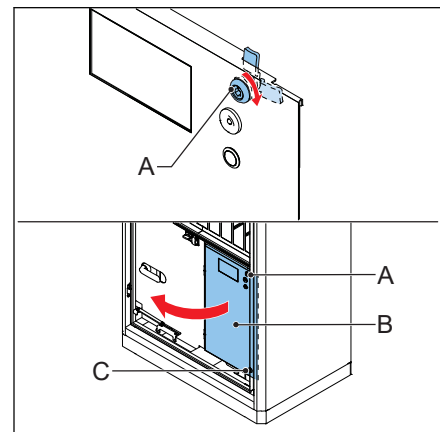

10.11 Close the door of the charge post

Preliminary requirements



- Door key of the charge post

**Danger:****Hazardous voltage**

- Make sure that only qualified personnel has access to the door key.



Note: There is one unique door key for each charge post.

Procedure



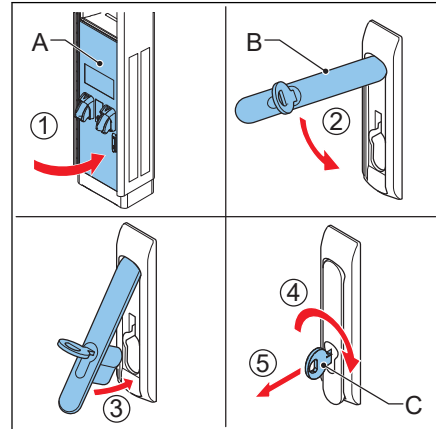

1. Close the door (A).
2. Turn the handle (B) counterclockwise.
3. Push the handle.
4. Turn the door key (C) clockwise to lock the door.
5. Remove the door key.



11 Generic procedures

11.1 Install a cable lug on a wire

Preliminary requirements

	<ul style="list-style-type: none"> • Wire cutter • Wire stripper pliers • Crimp plier 		<ul style="list-style-type: none"> • 
	<ul style="list-style-type: none"> • Cable lug 		



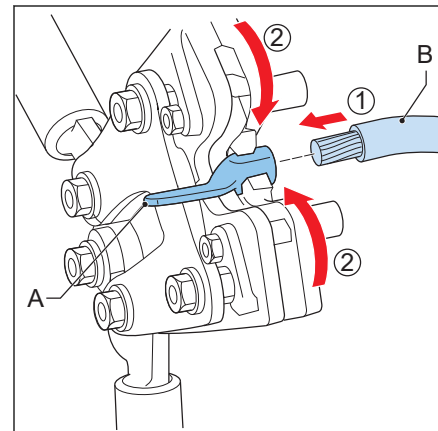

Procedure

1. Make sure that the diameter of the cable lug is correct. The cable lug must be compatible with the wire.
2. Strip the insulation from the wire. The stripped length must be the same as the length of the cavity of the cable lug.
3. Insert the conductor of the wire into the cavity of the cable lug.
4. Install the cable lug on the wire. Use the crimp plier.



11.2 Install a ferrule on a wire

Preliminary requirements

	<ul style="list-style-type: none"> • Wire cutter • Wire stripper pliers • Crimp plier 		<ul style="list-style-type: none"> • 
	<ul style="list-style-type: none"> • Ferrule 		

Procedure

1. Make sure that the diameter of the ferrule is correct. The ferrule must be compatible with the wire. Obey the technical specifications set by the manufacturer. Refer to section 12.18.
2. Strip the insulation from the wire. The stripped length must be the same as the length of the cavity of the ferrule. For the specifications, refer to section 12.18.
3. Put the ferrule in the crimp plier.
4. Insert the wire into the cavity of the ferrule.
5. Install the ferrule on the wire. Use the crimp plier.

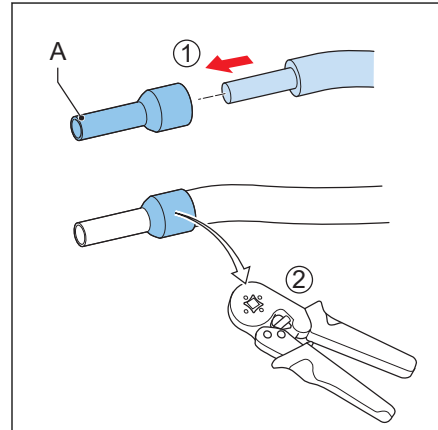

11.3

Install insulating heatshrink tubing on a wire

Preliminary requirements

	<ul style="list-style-type: none"> • Heat gun 		<ul style="list-style-type: none"> •
	<ul style="list-style-type: none"> • Heatshrink tubing 		

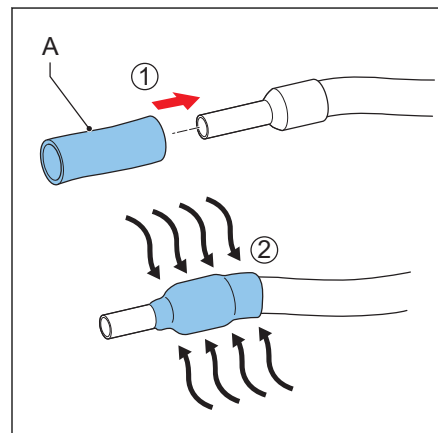

Procedure

1. Clean the part of the wire, or the wire with the cable lug, that you want to insulate.
2. Cut a piece of heatshrink tubing.
 - Make sure that the length covers all electrical cables.
 - Use a diameter that is larger than the wire diameter.
3. Install the piece of heatshrink tubing on the wire or the wire with the cable lug.
4. Shrink the heatshrink tubing on the wire. Use the heat gun. Make sure that you shrink the heatshrink tubing evenly on all sides.



11.4 Connect a wire that has a cable lug

Preliminary requirements

	<ul style="list-style-type: none"> Torque screwdriver, cross 		<ul style="list-style-type: none"> 
---	---	---	---

Procedure

1. Loosen the bolt of the connection pin (A) on the busbar (B).
2. Install the eye of the cable lug (C) on the connection pin.
3. Tighten the bolt of the connection pin on the busbar to the correct torque. For the torque specification, refer to section 12.13.
4. Make sure that unused wires are protected and cannot touch metal parts.

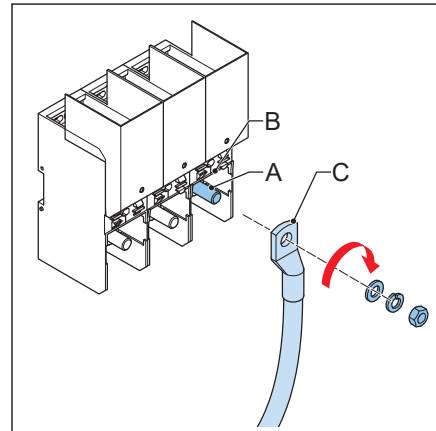

11.5 Connect a wire that has a ferrule

Preliminary requirements

	<ul style="list-style-type: none"> 
---	---

Procedure

1. Loosen the screw of the connection on the terminal.
2. Install the ferrule in the connection of the terminal.
3. Tighten the screw to the correct torque. For the specifications, refer to section 12.13.
4. Make sure that unused wires are protected and cannot touch metal parts.

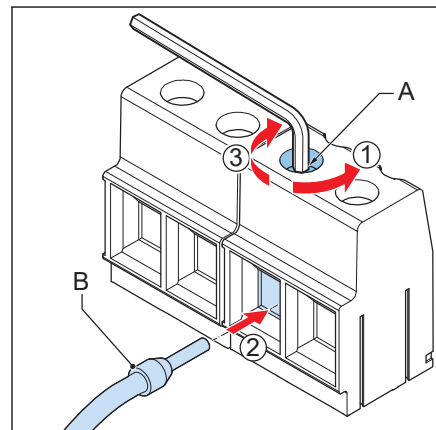

12 Technical data

12.1 EVSE type

The EVSE type is a code, mentioned on the type plate. Refer to section 3.2.
The code is made out of 3 parts: T U V

Code part	Description	Value	Meaning of the value
T	Model	THP	Terra high power
U	Part	CP500	Charge post, 500 A DC output
		-	Power cabinet
V	EV charge cable connection, for a charge post	C	One CCS connection
	Peak output power, power cabinet	360	Peak output power [kW]

Examples

HP CP500 C:

- T = HP, Model = Terra high power
- U = CP500, Part = charge post 500 A DC output
- V = C, EV charge cable connection = one CCS connection

12.2 Parts included in the delivery

Parameter	Specification
Charge post	Refer to the type plate. Refer to section 3.2.
Power cabinet	Refer to the type plate. Refer to section 3.5.1.
Door keys	Door keys for the power cabinet and the charge post
Eye bolts to hoist the power cabinet	M16, 63 mm (2.5 in)
Caps to replace the eye bolts after transport of the power cabinet	To fit in the holes for the eye bolts
Eye bolts to hoist the charge post	M10, 45 mm (1 3/8 in)
Caps to replace the eye bolts after transport of the charge post	To fit in the holes for the eye bolts



Note: It is possible that more parts are required in the delivery. Refer to the order.

12.3 Required tools for installation

Parameter	Specification
Hoisting equipment or forklift truck	Capable to lift the EVSE safely. Take into account the dimensions, the mass, and the center of gravity.
Swivel eye bolts or bolts with lifting loops (to use with hoisting equipment) As a standard, eye bolts are installed on the cabinets. Refer to section 12.2.	Thread M10 for the charge post Thread M16 for the power cabinet
Bolts	Size M16
Hex keys	Standard set of hex keys
Open spanners	Standard set of open spanners
Torque socket wrench	For the torque specifications, refer to section 12.13.
Screwdriver, cross	Size M5 (8 mm (0.3 in))
Wire cutter	-
Wire stripper pliers	-
Crimp pliers	-

12.4 Required parts for installation

Part	Specification
Fasteners and washers, to connect the charge post to the foundation	M12, class A2, length 70 mm (2.75 in)
Fasteners and washers, to connect the power cabinet to the foundation	M16, class A2, length 70 mm (2.75 in)
Fasteners and washers, for the earthing connections	M11, class A2, length 70 mm (2.75 in)

Table 1: Cable lugs

Location	Wire	Size	Maximum width		Maximum length	
			[mm]	[in]	[mm]	[in]
Power cabinet	PE	M12	35	1.4	70	2.7
		M10	25	1.0	50	2.0
		M6	12	0.5	40	1.6
	AC input power	M12	39	1.5	70	2.7
	DC power	M12	39	1.5	70	2.7
Charge post	PE	M8	22	0.9	40	1.6
		M6	12	0.5	40	1.6
	DC power	M12	39	1.5	40	1.6

12.5

General specifications

Parameter	Specification
Compliance and safety	CE
Ingress protection rating	IP54
EMC rating for the charge post	<p>The charge post complies with these standards:</p> <ul style="list-style-type: none"> • EN 61000-6-3 : 2007 + A1: 2001 Emission standard for residential, commercial and light-industrial environments (Class B) • EN 61000-6-2 : 2005 Immunity for industrial environments • EN 301489-1 V2.2.0 : 2017 <p>The charge post also complies with the less strict requirements in these standards:</p> <ul style="list-style-type: none"> • EN 61000-6-4: 2007 + A1: 2011 Emission standard for industrial environments (Class A) • EN 61000-6-1 : 2007 Immunity for residential, commercial and light-industrial environments
EMC rating for the power cabinet	<p>The power cabinet complies with these standards:</p> <ul style="list-style-type: none"> • EN 61000-6-4:2007 + A1 Emission standard for industrial environments (Class A) • EN 61000-6-2: 2005 Immunity for industrial environments <p>If the power cabinet must comply with Class B (residential), install an external EMC filter: Schaffner type FN 3359HV-400-99. To order this part, give the global ID: 6AGC079955. When this external EMC filter is installed, the power cabinet complies with this standard:</p> <ul style="list-style-type: none"> • EN 61000-6-3 : 2007 + A1 2011 Emission standard for residential, commercial and light-industrial environments (Class B)

12.6 Electrical installation specifications

12.6.1 General requirements

Parameter	Specification
Circuit breaker	Use a circuit breaker with the option for an under voltage release device.
Surge protection device	Type 2
Residual-current device	In the range of 30 mA up to 300 mA
Power consumption of the power cabinet	In standby status: ≤ 86.7 W
Power consumption of the charge post	In standby status: ≤ 70 W With the LEDs on: ≤ 145 W
Earthing system	TN-C
	TN-S
	TN-CS
	TT
Input AC power connection	400/230 VAC 3W + PE
Input voltage range	400 V AC +/- 10 % (50 Hz or 60 Hz)
Nominal input current	550 A at 400 V AC
Maximum input current	610 A at 360 V AC
Cores	According to IEC 60446, aluminum - copper
Phases cross section range (recommended)	2 x 120 mm ² to 180 mm ² per phase or 1 x 240 mm ² to 300 mm ² per phase
PE cross section range (recommended)	120 mm ² to 180 mm ²
Cable lug maximum width	40 mm, M12
Power factor at full load	> 0.99
Efficiency	≥ 92 % at ≥ 20 % load ≥ 95 % at full load
THD	< 6 % for > 90 kW output power
Reactive power (capacitive)	≥ 9 % at full load

12.6.2 Requirements for precommissioning

Parameter	Specification
Circuit breaker	25 A type C
Surge protection device	Type 2
Power consumption	In standby status: ≤ 1800 W
Earthing system	TN-C
	TN-S
	TN-CS
	TT
Input AC power connection	230 V AC 1P + PE

Parameter	Specification
Input voltage range	230 V AC +/- 10 % (50 Hz or 60 Hz) Nominal input
Nominal input current	550 A at 400 V AC
Maximum input current	15 A at 230 V AC
Cores	According to IEC 60446
Cross section range	3 x 4 mm ²
Maximum input current	20 A at 230 V AC
Power factor at full load	> 0.95

12.6.3

Requirements for charge post auxiliary

Parameter	Specification
Surge protection device	Type 2
Power consumption	In standby status: ≤ 1500 W
Earthing system	TN-C TN-S TN-CS TT
Input AC power connection	400 / 230 V AC 3W + PE
Input voltage range	400 V AC +/- 10 % (50 Hz or 60 Hz)
Input current	2 A at 380 V AC
Cores	According to IEC 60446
Cross section range	4 x 4 mm ²
Maximum input current	3 A at 280 V AC

12.7

DC output specifications

Parameter	Specification
Output voltage range	150 - 920 V DC
Maximum output current	500 A DC
Output power	360 kW up to 40 °C (104 °F)
DC output current	500 A CCS (liquid cooled)
Cores	according to IEC 60446 aluminum/ copper
Phases cross section range	2 x 120 mm ² to 180 mm ² per pole or 1 x 240 mm ² to 300 mm ² per pole
Earth cross section range	35 mm ²
Cable lug maximum width	40 mm, M12

12.8 Current peaks during the start of a charge session (DC output)

Parameter	Specification
Duration of the current peaks	25 μ s
Maximum current peak	60 A

12.9 Logic interfaces specifications

Parameter	Specification
RFID standard	ISO/IEC 14443A/B, ISO/IEC 15393
RFID supported applications	FeliCa™ 1, NFC, Mifare, Calypso
Network connection	4G, 3G, 2G, Ethernet

12.10 Mass and center of gravity

12.10.1 Mass

Parameter	Specification	
	[kg]	[lbs]
Mass of the power cabinet	1400	3086.5
Mass of the charge post	250	551.2

12.10.2 Center of gravity, power cabinet

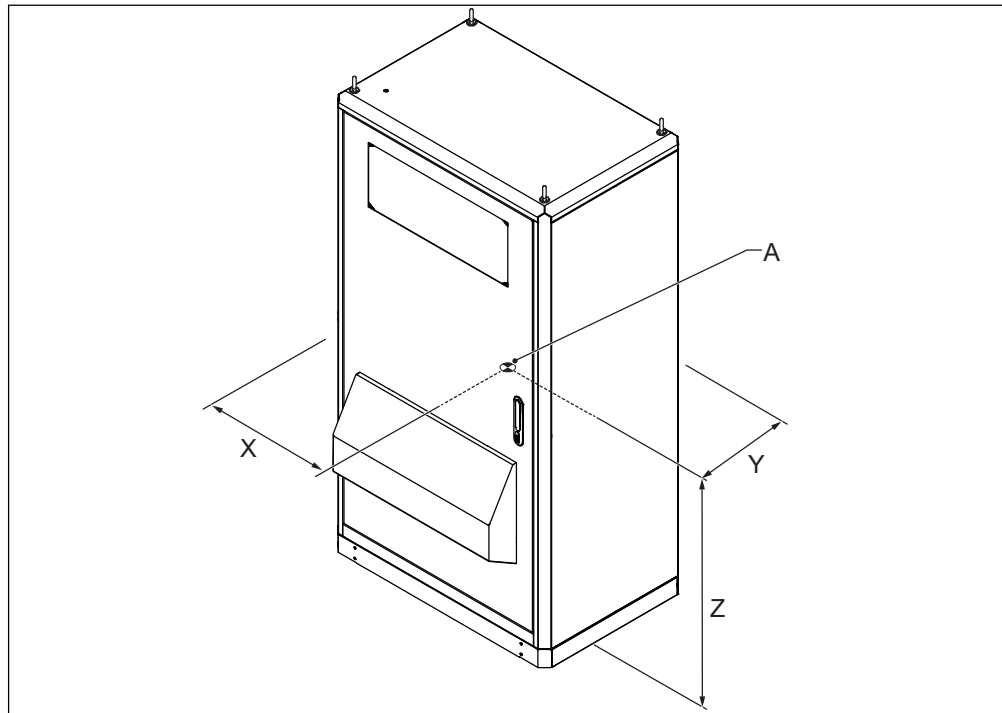

A Center of gravity

Parameter	Specification	
	[mm]	[in]
X	587	23.1
Y	100	3.93
Z	1068	42.1

12.10.3 Center of gravity, charge post

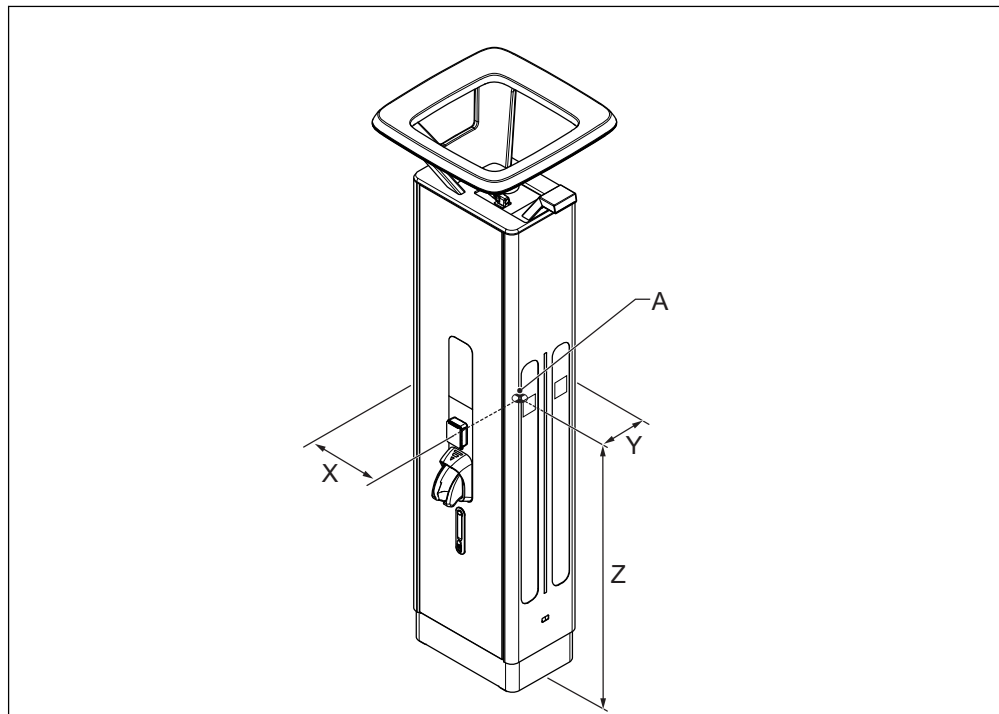

A Center of gravity

Parameter	Specification	
	[mm]	[in]
X	353	13.9
Y	244	9.6
Z	1096	43.2

12.11 Ambient conditions

Parameter	Specification
Operation temperature	-35 °C to +55 °C (-31 °F to +131 °F) Derating applies
Storage	+5 °C to +40 °C (+41 °F to 104 °F) RH 5 to 85%
Environment	IP54, rainproof

Parameter	Specification
	IK10 (screen: IK08)
Altitude	Maximum 2000 m (6562 ft) above the sea level

12.12 Noise level

Noise level	Specification [dB(A)]
Charge post, 500 A continuous up to 35 °C	≤ 60 at 1 m (39.4 in)
Maximum noise level of the charge post	68 at 1 m (39.4 in)
Power cabinet	≤ 65 at 1 m (39.4 in)

12.13 Torque specifications

Parameter	Specification	
	[Nm]	[lb-in]
Power cabinet, fasteners to the foundation	80	708
Power cabinet, nuts on the PE busbars	30	266
Power cabinet, nuts on the AC power busbars	30	266
Power cabinet, screws in the terminal blocks	1.3	11.5
Power cabinet, nuts on the DC power busbars	30	266
Charge post, fasteners to the foundation	80	708
Charge post, fasteners on the PE busbar	Between 33 and 44	Between 292 and 389
Charge post, screws in the terminal blocks	1.3	11.5
DC input cable to the connector	30	265.5
M5 fasteners (if not specified)	3.5	31.0
M6 fasteners (if not specified)	9	79.7
M8 fasteners (if not specified)	20	177
M10 fasteners (if not specified)	40	354
M12 fasteners (if not specified)	70	619.5
M16 fasteners (if not specified)	180	1593

12.14 Dimensions

12.14.1 Power cabinet

Parameter	Specification	
	[mm]	[in]
Width (X-dimension)	1170	46.1
Depth (Y-dimension)	770	30.3
Height (Z-dimension) (including eye bolts)	2243	88.3
Required cable slack for the AC input cable (measured from the top of the foundation)	from 200 to 250	from 7.9 to 9.9
Required cable slack for the PE cable (measured from the top of the foundation)	from 400 to 500	from 15.8 to 19.7
Required cable slack for the DC output cable - positive (measured from the top of the foundation)	from 230 to 280	from 9.1 to 11.0
Required cable slack for the DC output cable - negative (measured from the foundation)	from 330 to 380	from 13.0 to 15.0
Required cable slack for the AC auxiliary power cable (measured from the top of the foundation)	1500	59.0
Required cable slack for the interlock and DC guard, and ETH cables (measured from the top of the foundation)	1500	59.0

12.14.2 Charge post

Parameter	Specification	
	[mm]	[in]
Width of the charge post (X-dimension)	590	23.2
Depth of the charge post (Y-dimension)	390	15.4
Height of the charge post (Z-dimension)	2300	90.6
Required cable slack for the PE wire (measured from the top of the foundation)	700	27.6
Required cable slack for the DC power cables (measured from the top of the foundation)	700	27.6
Required cable slack for the AC auxiliary power cable (measured from the top of the foundation)	1200	47.2

Parameter	Specification	
	[mm]	[in]
Required cable slack for the interlock and DC guard cable (measured from the top of the foundation)	1200	47.2
Required cable slack for the ETH cable (measured from the top of the foundation)	1200	47.2

Parameter	Specification	
	[m]	[ft]
Length of the charge cable, with retraction system	4.8	15.7
Cable reach, approximately	3	9.8

12.14.3 Height of user operable elements

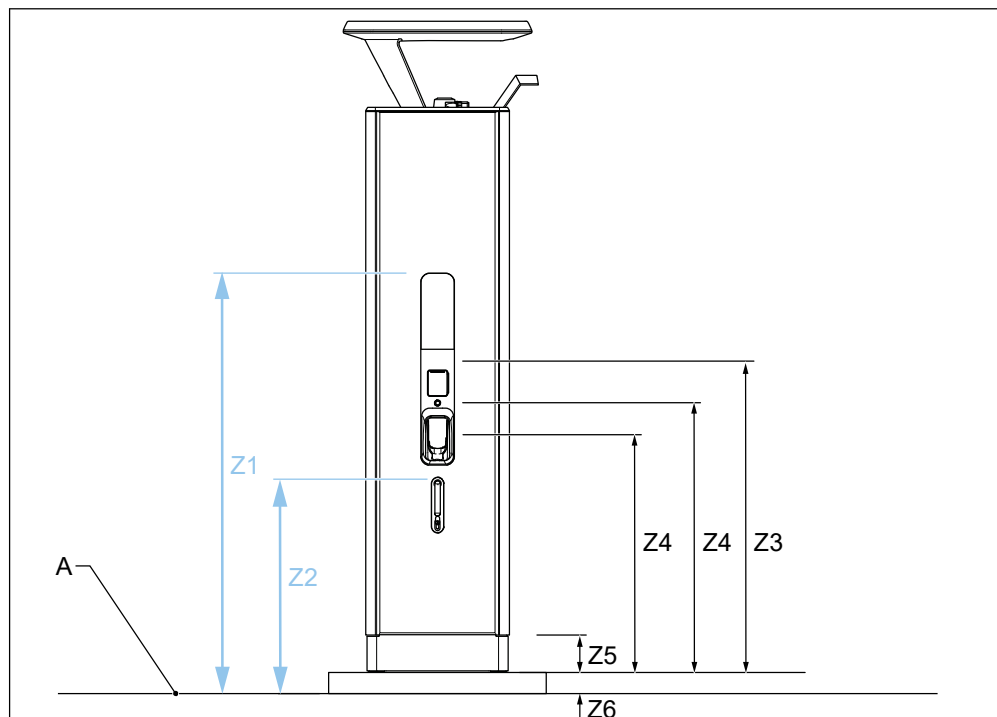

Parameter	Specification	Specification	
		[mm]	[in]
Z1	Advised maximum curb height	102	4
Z2	Bottom of the authentication cluster	750 or higher	29.5
Z3	CCS connector when holstered – center of grip	775	30.5
Z4	CHAdeMO connector when holstered – center of grip	790	31.1

Parameter		Specification	
		[mm]	[in]
Z5	Top of the authentication cluster	955	37.6
Z6	Bottom of the touch screen display	1026	40
Z7	Advised maximum height for user operable elements if the EVSE is placed on a curb. This requires HMI customization.	1118	44
Z8	Top of the touch screen display	1223	48.1

12.15 Space requirements

12.15.1 Power cabinet

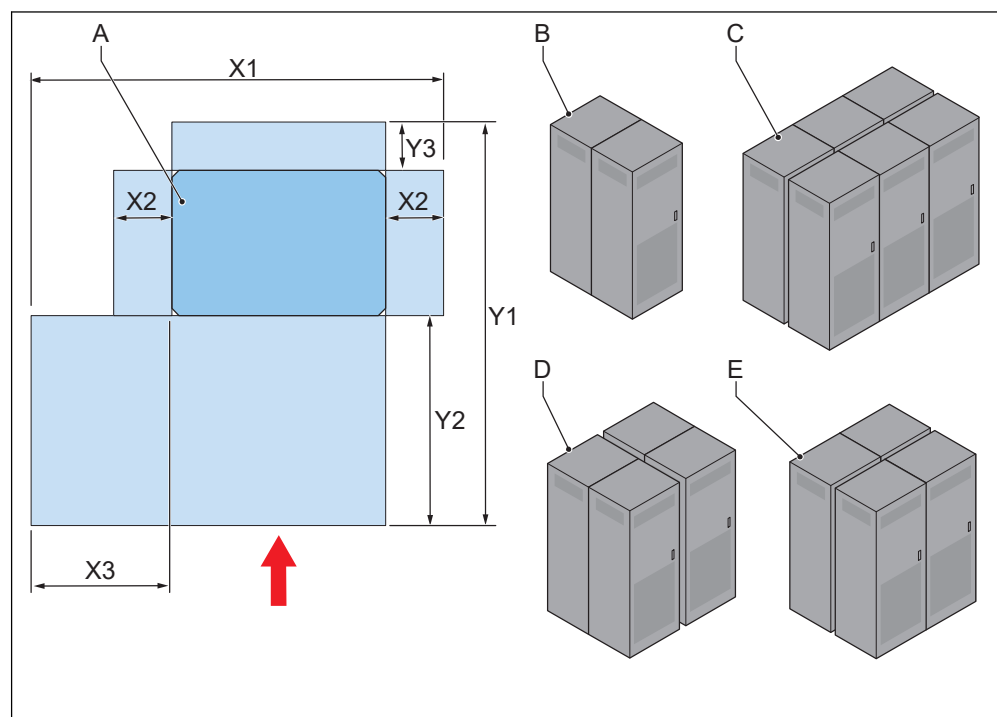

- A Power cabinet
- X1 Total width required for the power cabinet
- X2 Space for air inlet on the side
- X3 Space to open the power cabinet door
- Y1 Total depth required for the power cabinet
- Y2 Space to open the power cabinet door
- Y3 Space for air outlet
- B Back to back configuration
- C Side by side configuration
- D Back to back configuration, four power cabinets
- E Side by side configuration, four power cabinets

Parameter	Specification for a single power cabinet	
	[mm]	[in]
X1	1170	47.2
X2	200	7.9
X3	650	25.6
Y1	770	30.3
Y2	1050	41.3
	650	25.6
Y3	100	3.9

Parameter	Specifications for power cabinets side by side	
	[mm]	[in]
X2	0	0
Y3	100 per power cabinet.	3.9 per power cabinet.

Parameter	Specifications for power cabinets back to back	
	[mm]	[in]
X2	100 per power cabinet.	3.9 per power cabinet.
Y3	0	0

12.15.2

Charge post

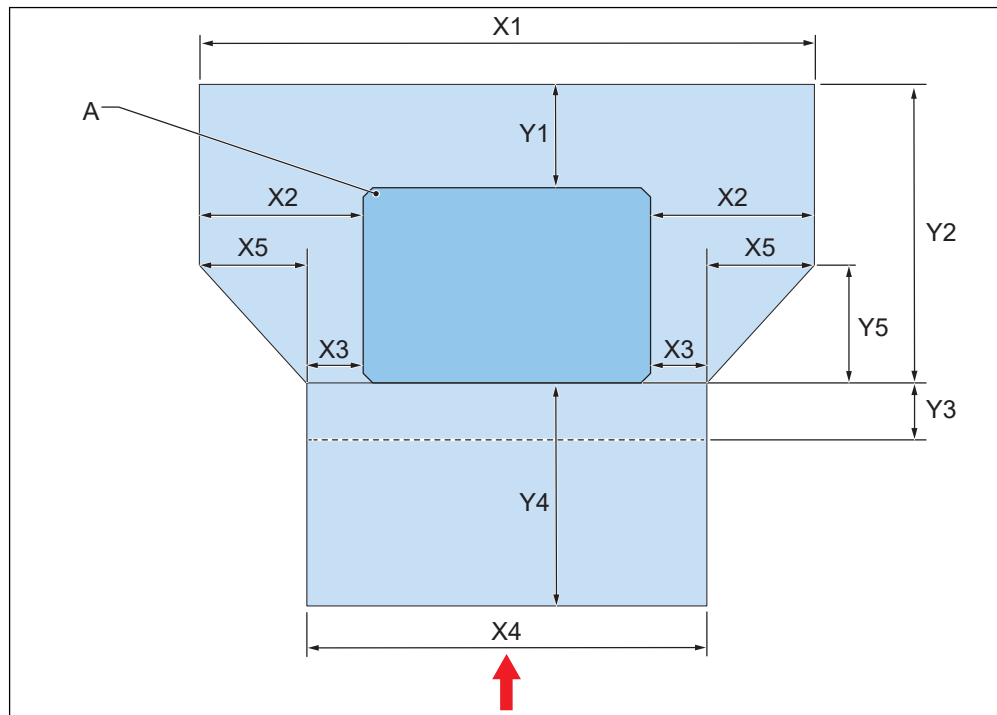

A	Charge post	Y1	Space required for cable replacement
X1	Total required width for the charge post	Y2	Total required depth for the charge post
X2	Space required for the air inlet and to open the side panel	Y3	Maximum sideways reach of the wheelchair user
X3	Space required at the sides to open the door	Y4	Space required to open the door
X4	Total required width to open the door	Y5	Required depth to open the side panel
X5	Required width to open the side panel		

Parameter	Specification	
	[mm]	[in]
X1	1490	58.7
X2	450	17.7
X3	105	4.1
X4	800	31.5
X5	345	13.6
Y1	400	15.7
Y2	775	30.6
Y3	254	10
Y4	490	19.3
Y5	345	13.6

12.15.3

Charge post: exceptions for bollards and other minor fixed obstacles



Note:

The bollards or minor fixed obstacles must have a maximum diameter of 150 mm (6 in), to permit service or maintenance operations.

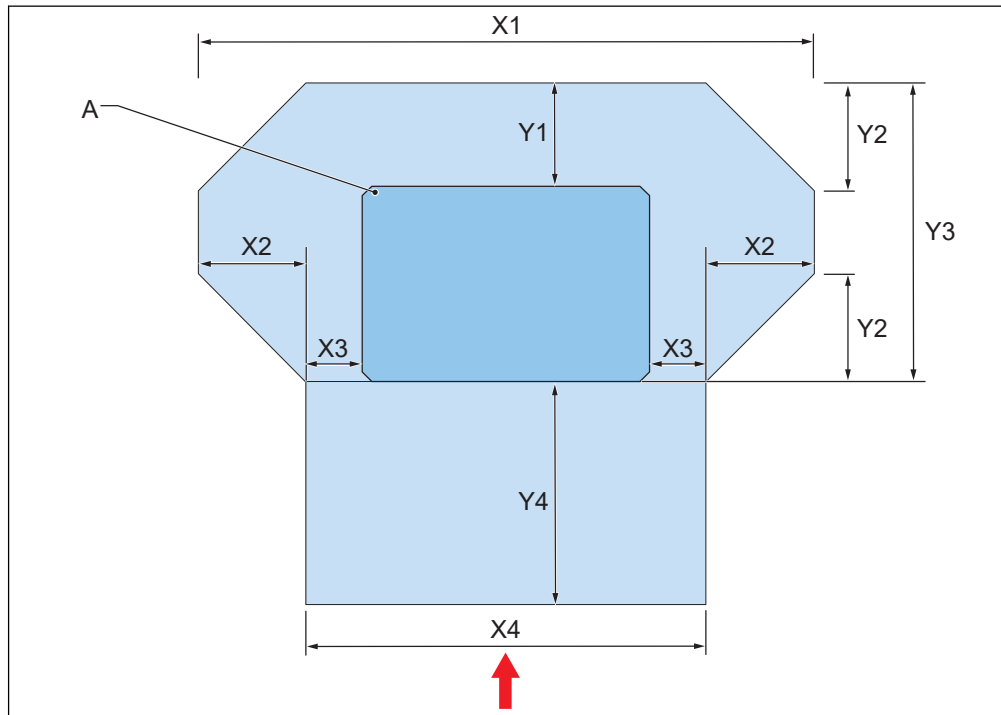

A	Charge post	Y1	Required depth to open the side panel
X1	Total width to open the side panels	Y2	Required depth to open the side panel
X2	Required width to open the side panel	Y3	Total required width to open side panels
X3	Space required at the sides to open the door	Y4	Space required to open the door
X4	Total required width to open the door		

Parameter	Specification	
	[mm]	[in]
X1	1190	46.8
X2	200	7.8
X3	105	4.1
X4	800	31.5
Y1	250	9.8
Y2	200	7.8
Y3	675	26.5
Y4	490	19.3

12.15.4

Distance requirements between power cabinet and charge post

Parameter	Specification	
	[m]	[ft]
Maximum distance between the power cabinet and the charge post	60	197

12.16 Foundation specifications

12.16.1 Power cabinet (prefab concrete)

General specifications

Parameter	Specification
Type	Base monoblock of support for cabinet, with plasticizer and waterproofing additive
Concrete class	C32 / 40
Exposure class	CX4 and XD25 according to UNI 11104:2018

Dimensions, side view

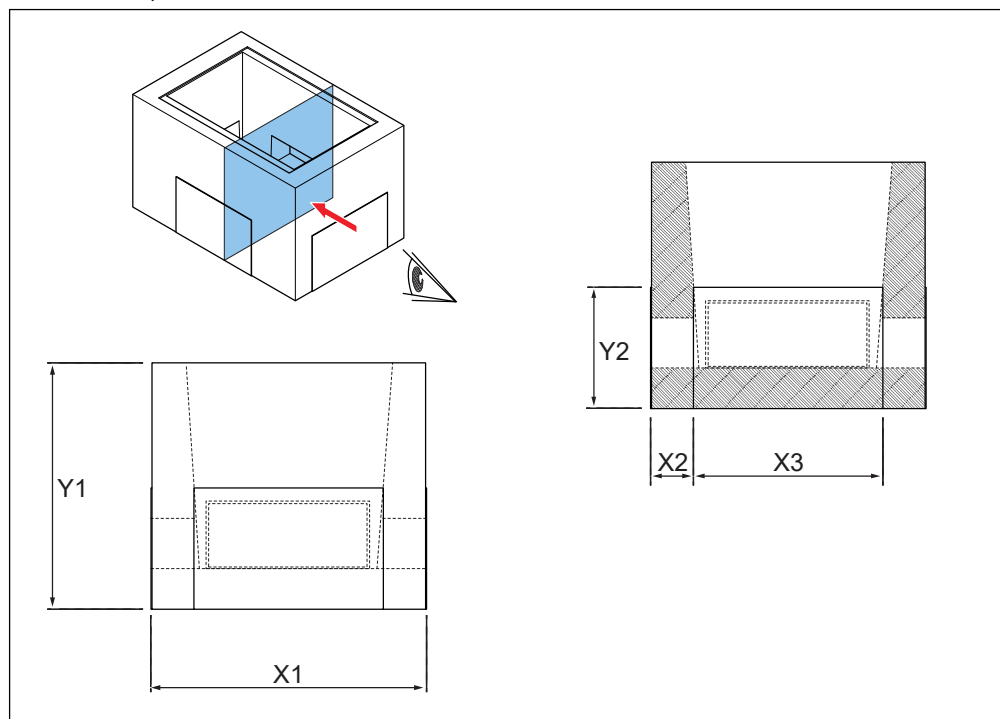

Parameter	Specification	
	[mm]	[in]
X1	800	31.5
X2	123	4.8
X3	554	21.8
Y1	720	28.3
Y2	354	13.9

Dimensions, front view

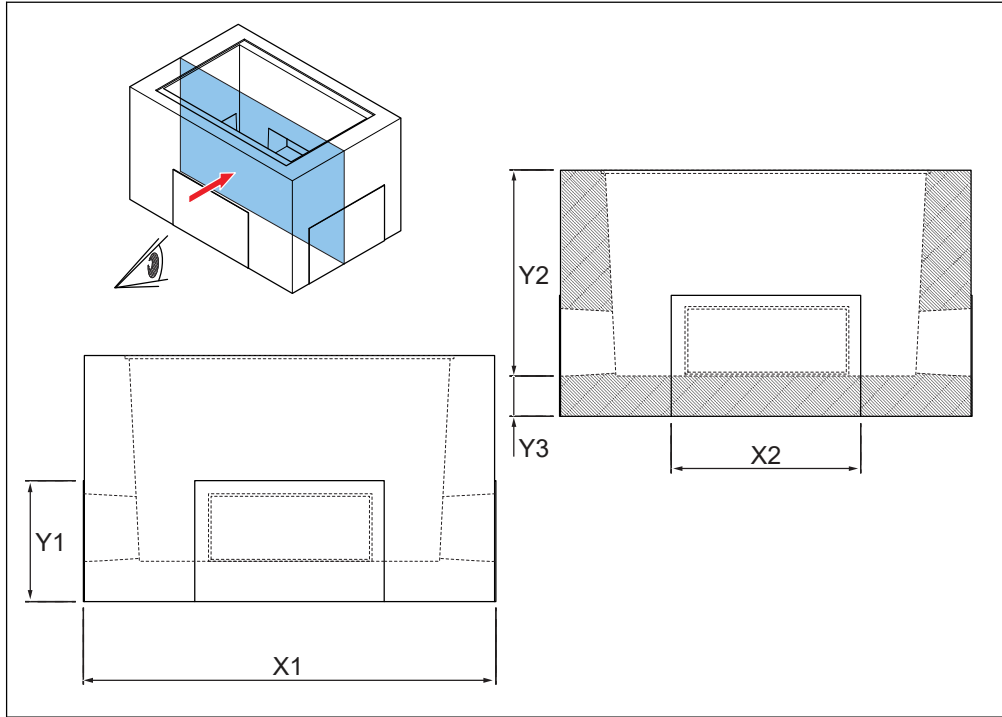

Parameter	Specification	
	[mm]	[in]
X1	1200	47.2
X2	554	21.8
Y1	354	13.9
Y2	600	23.6
Y3	120	4.7

Dimensions, top view

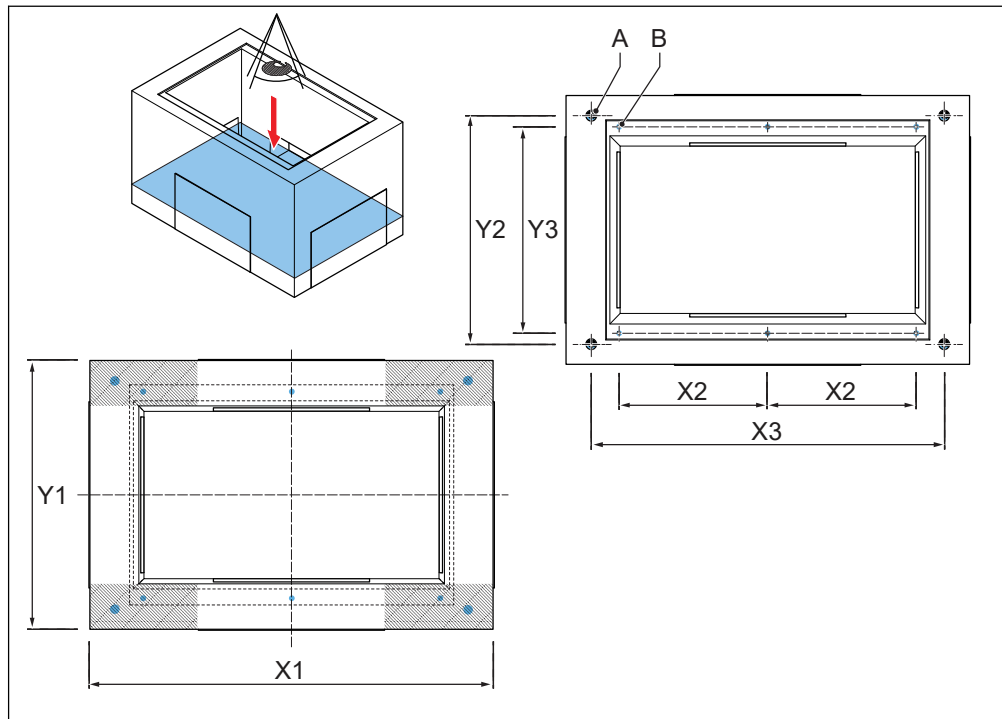

Parameter	Specification	
	[mm]	[in]
X1	1200	47.2
X2	442	17.4
X3	1050	41.3
Y1	800	31.5
Y2	650	25.6
Y3	614	24.2

Parameter	Specification
A (4x)	M16
B (6x)	M8

12.16.2 Power cabinet (metal frame)

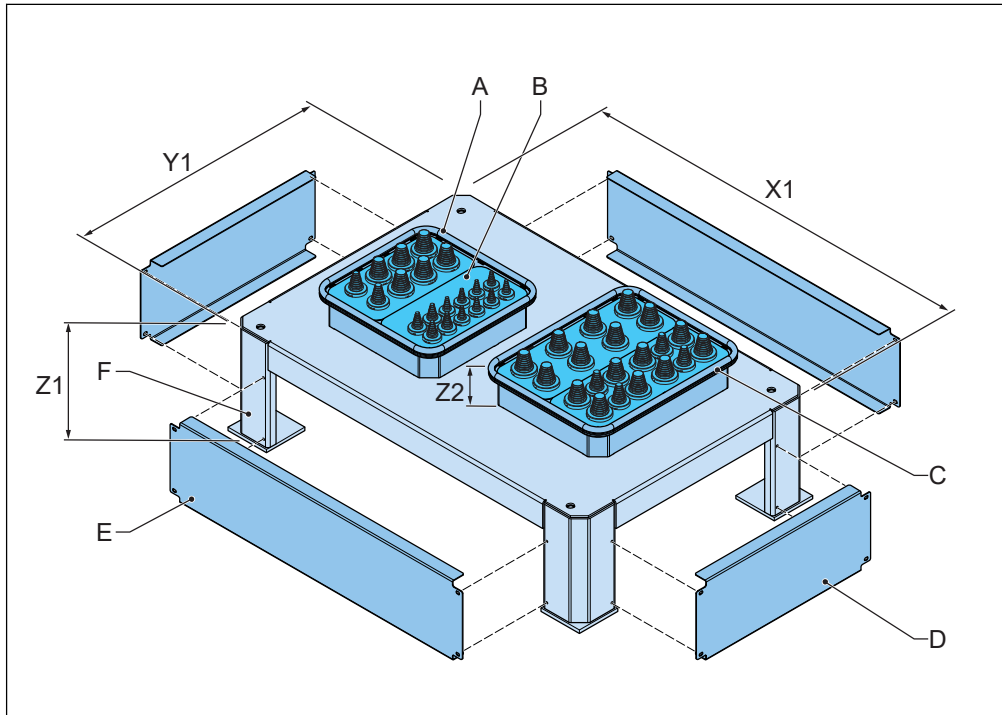

- | | | | |
|---|--|----|---------------------------|
| A | Gasket for the AC and signal gland plate | F | Metal frame |
| B | Gland plates | X1 | Width of the foundation |
| C | Gasket for the DC gland plate | Y1 | Depth of the foundation |
| D | Cover plate left and right | Z1 | Height of the foundation |
| E | Cover plate front and rear | Z2 | Height of the gland plate |

Parameter	Specification	
	[mm]	[in]
X1	1190	46.9
Y1	790	31.1
Z1	320	12.6
Z2	79	3.1

12.16.3 Gland plates for the metal foundation of the power cabinet

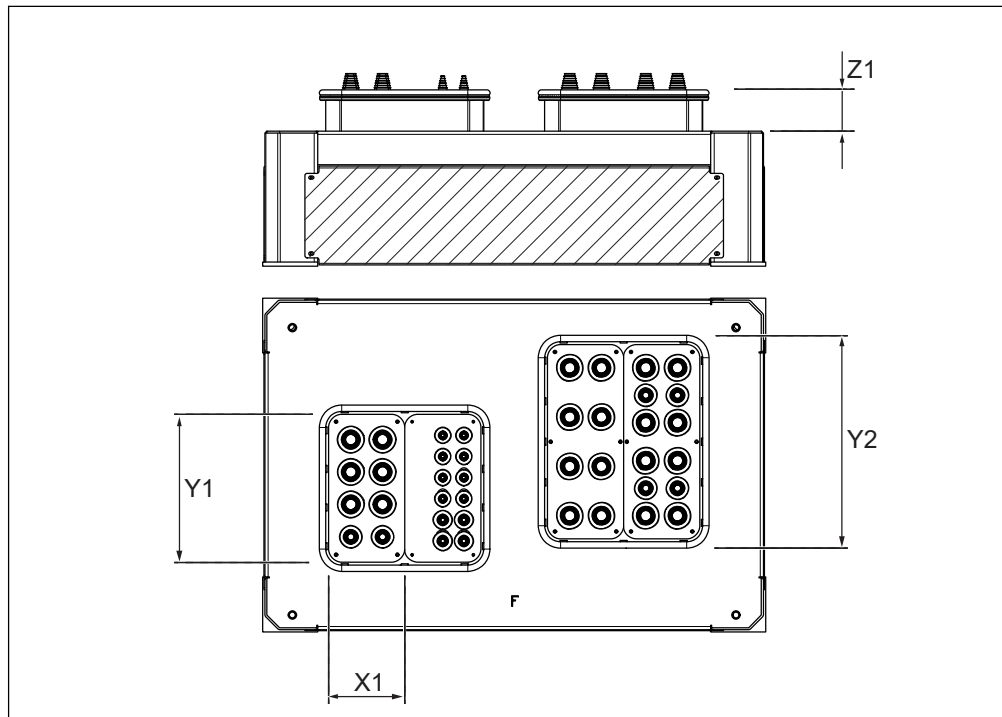

Parameter	Specification	
	[mm]	[in]
X1	180	7.1
Y1	350	13.8
Y2	460	18.1
Z1	79	3.1

12.16.4 Charge post (metal frame)

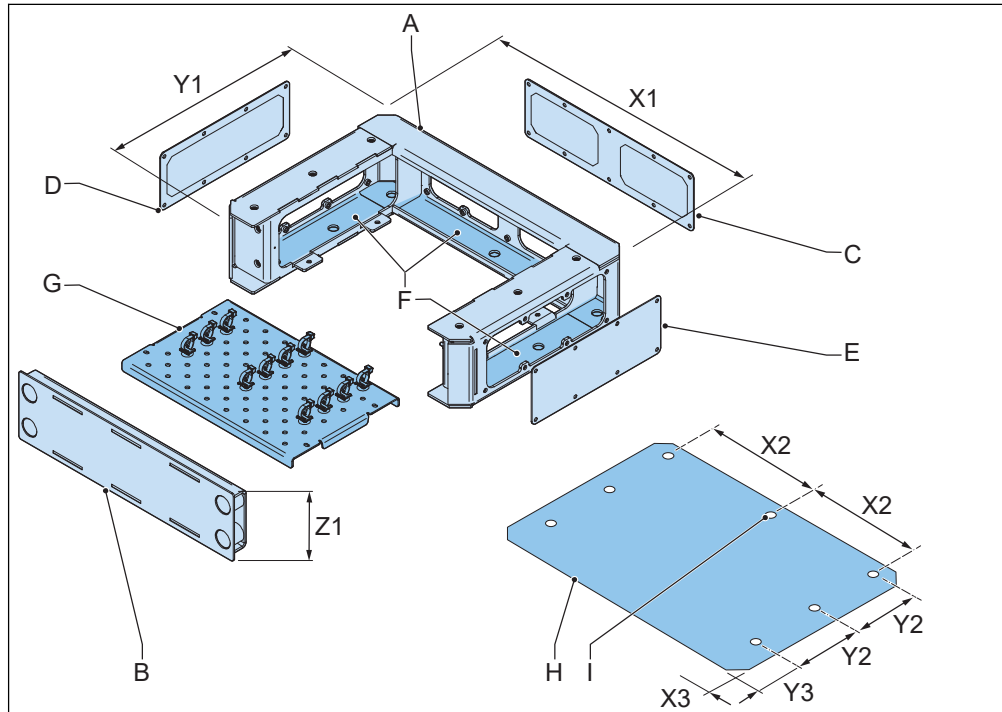

- | | | | |
|---|-------------------------|----|---|
| A | Foundation | I | Footprint of the foundation |
| B | Front cover | X1 | Width of the foundation |
| C | Rear gland plate | Y1 | Depth of the foundation |
| D | Left gland plate | Z1 | Height of the foundation |
| E | Right gland plate | X2 | Distance between the holes |
| F | Cable trays | X3 | Distance between the hole and the edge of the footprint |
| G | Tie plate | Y2 | Distance between the holes |
| H | Holes for the fasteners | Y3 | Distance between the hole and the edge of the footprint |

Parameter	Specification
X1	620 mm (24.4 in)
Y1	440 mm (17.3 in)
Z1	152 mm (5.98 in)
X2	263 mm (10.4 in)
X3	47 mm (1.90 in)
Y2	150 mm (5.9 in)
Y3	100 mm (3.40 in)
Mass	24 kg (52 lb)
Fasteners to connect the charge post to the foundation (included in the delivery)	6 x M12 Class 10.9 length 30 mm (1.2 in)

12.16.5 Charge post (prefab concrete)

Foundation mass and loads

Parameter	Specification
Mass	1030 kg (2271 lb)
Nd	15.06 kN (3386 klbf)
Vd	5.25 kN (1180 klbf)
Md	8.36 kNm (74.1 klb-in)

Dimensions, side views

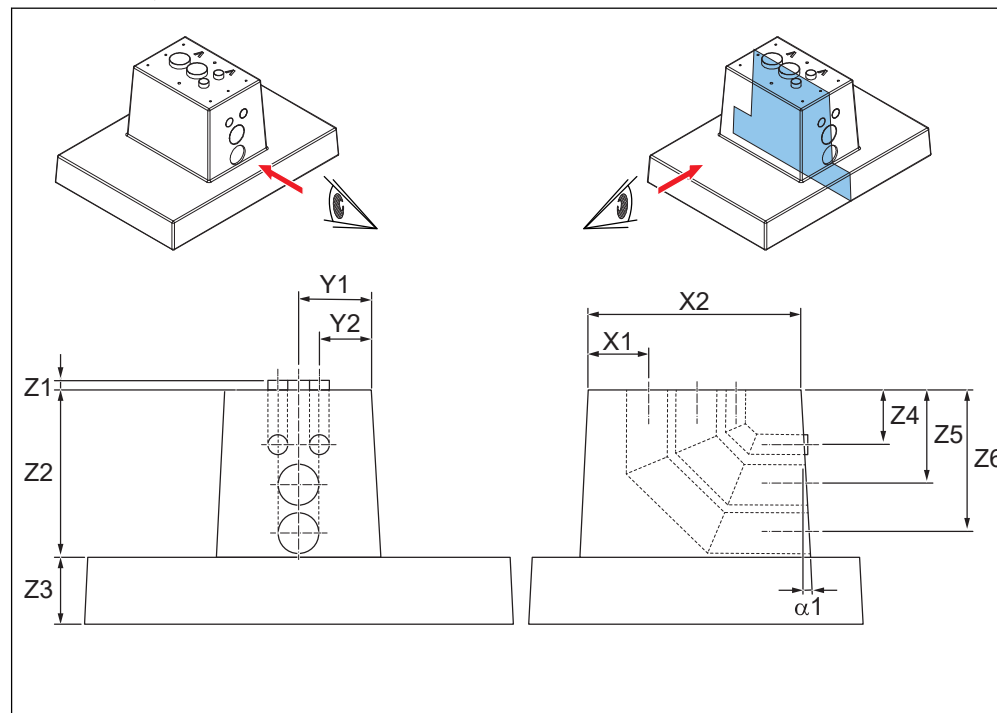

Parameter	Specification	
	[mm]	[in]
X1	175	6.89
X2	640	25.2
Y1	220	8.66
Y2	157.5	6.20
Z1	30	1.2
Z2	500	19.7
Z3	200	7.87
Z4	162.5	6.40
Z5	282.5	11.1
Z6	428	16.9

Parameter	Specification
α_1	3°

Dimensions, top view

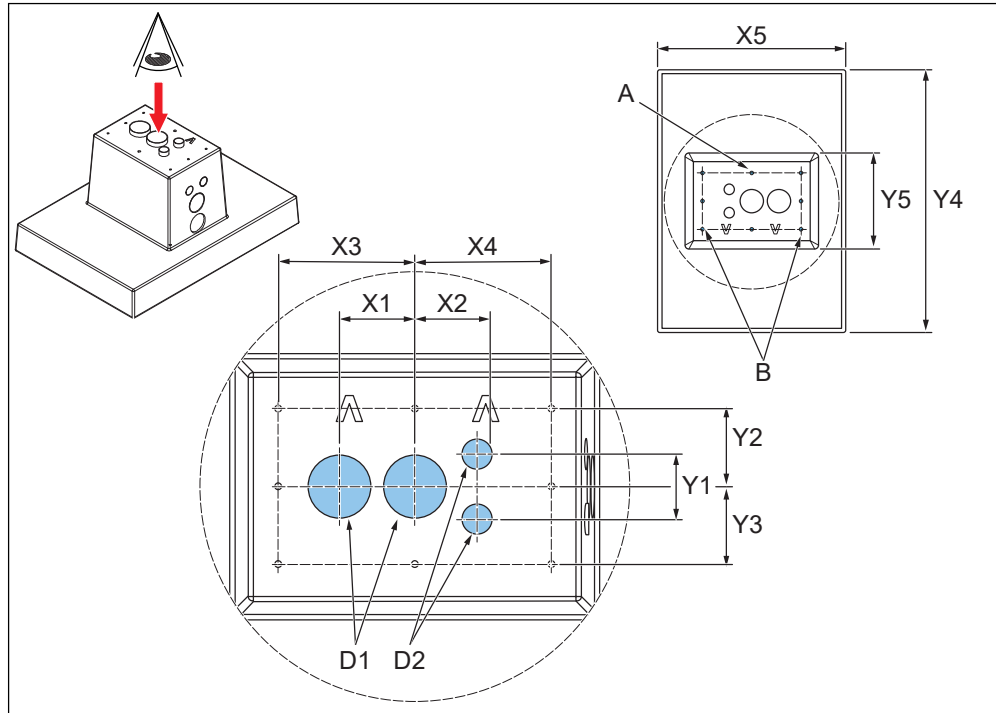

Parameter	Specification	
	[mm]	[in]
X1	145	5.71
X2	120	4.72
X3	263	10.4
X4	263	10.4
Y1	125	4.92
Y2	150	5.91
Y3	150	5.91
Y4	1400	55.1
Y5	440	17.3
D1, diameter	125	4.92
D2, diameter	125	4.92
D3, diameter	60	2.36

Parameter	Specification
α_1	3°
Tube diameter for D1	125/119 mm (4.92/44.1 in)
Tube diameter for D2	125/119 mm (4.92/44.1 in)

Parameter	Specification
Tube diameter for D3	60/56 mm (2.36/2.20 in)
A (2x)	DEMU anchor type 1988 type M16 depth 20 (8.66)
B (6x)	DEMU T-FIXX A4 anchor type M12 depth 115 (4.53)

12.16.6 Gland plates for the metal foundation of the charge post

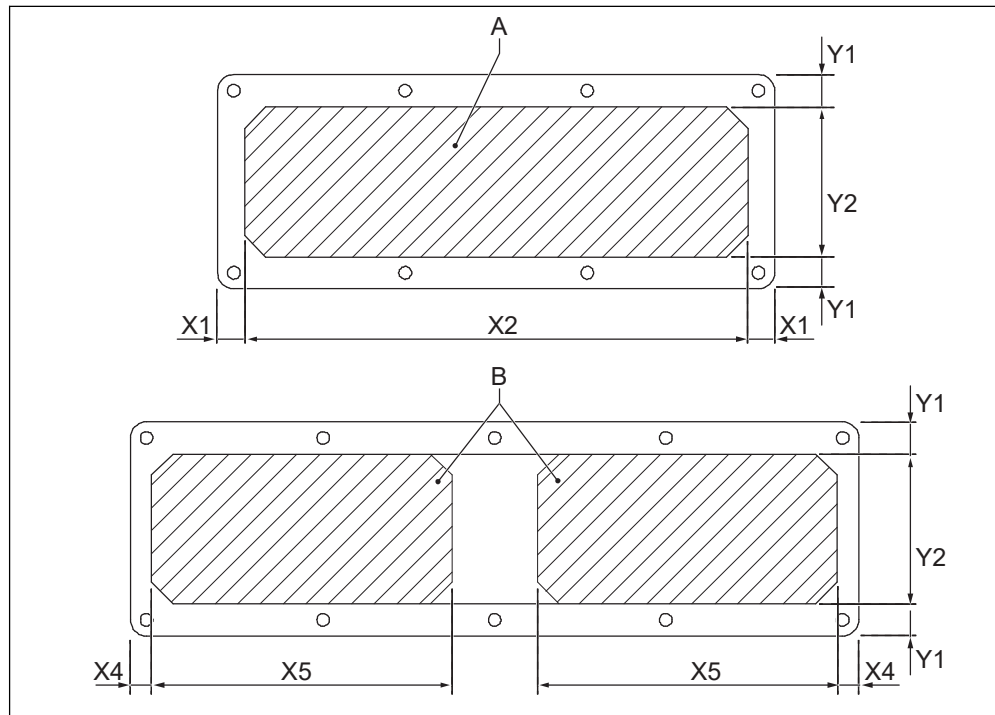

A Drilling area for the side gland plate

B Drilling area for the rear gland plate

Parameter	Specification	
	[mm]	[in]
X1	15.9	0.63
X2	298.5	11.75
X3	19.1	0.75
X4	12.7	0.50
X5	177.8	7.00
Y1	19.1	0.75
Y2	89.9	3.50

12.16.7 Charge post (custom)

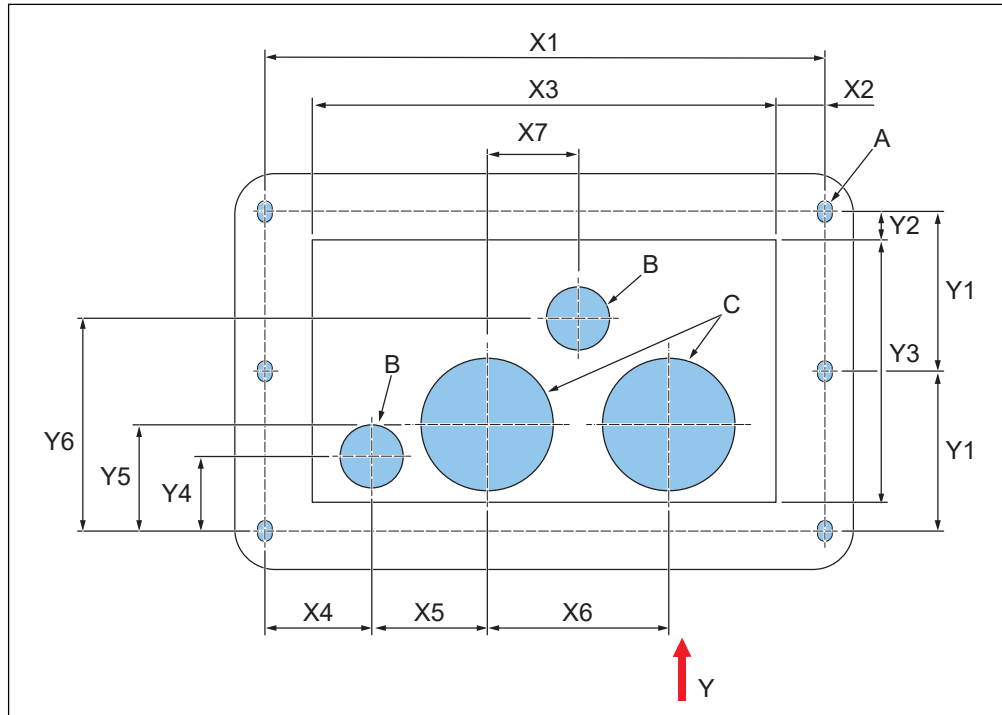

Note: The arrow shows the front side of the charge post.

Parameter	Specification	
A (6x)	For M12 fasteners diameter 14 (0.6)	
Parameter	Specification	
	[mm]	[in]
X0	580	22.8
X1	526	20.7
X2	45	1.8
X3	436	17
X4	100	3.9
X5	110	4.3
X6	170	6.7
X7	85	3.3
Y0	371	14.6
Y1	150	5.9
Y2	26	1.0
Y3	248	9.8
Y4	70	2.8

Parameter	Specification	
	[mm]	[in]
Y5	100	3.9
Y6	200	7.9

Cable conduit hole	Maximum diameter	
	[mm]	[in]
C1	60	2.4
C2	60	2.4
C3	126	5.0
C4	126	5.0

Function for cable conduit holes, 350 kW static system

Cable conduit hole	Cable conduit for these cables	
	Primary power cabinet	Secondary power cabinet
C1	AC power	AC power
C2	ETH, interlock and DC guard: to the secondary power cabinet	ETH, interlock and DC guard: to the primary power cabinet
C3	ETH, interlock and DC guard: to the charge post	None
C4	AC auxiliary: to the charge post	None
C5 and C6	DC power: to the secondary power cabinet	None
C7 and C8	DC power: to the charge post	DC power: to the primary power cabinet

12.17

Overview of the cable conduits



Note: For a detailed overview of all electrical connections, refer to section 12.19.

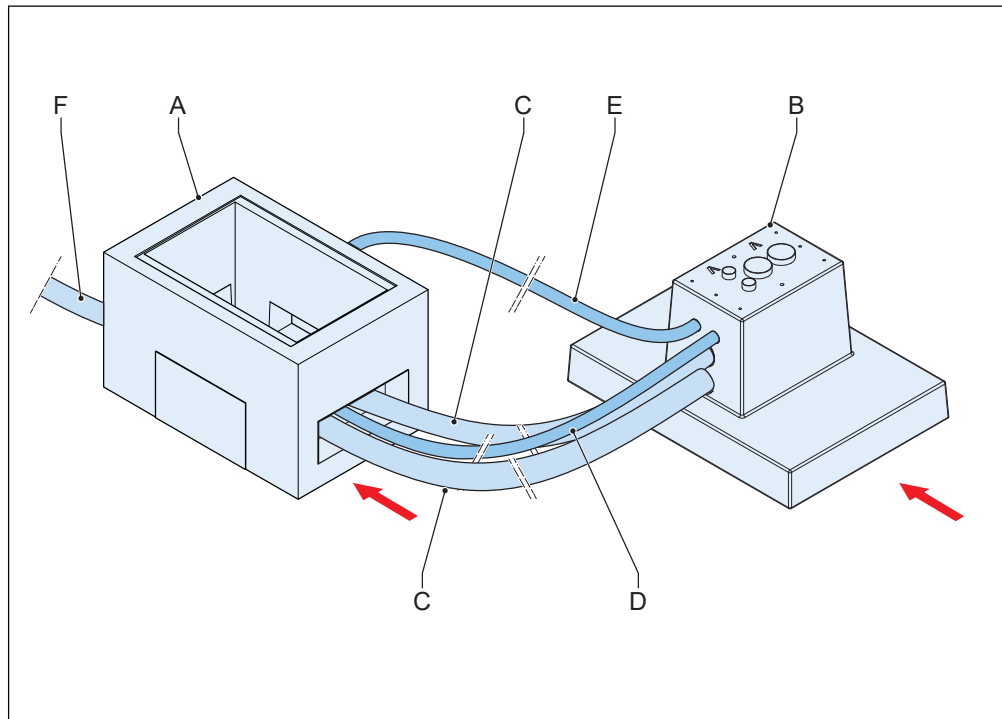

A Foundation of the power cabinet B Foundation of the charge post



Note: The arrows show the front side of the charge post and the power cabinet.

Cable conduit	Cables
C	DC power
D	AC auxiliary power PE
E	ETH Interlock DC guard
F	AC power

12.18 Cable specifications

12.18.1 AC input cable for the power cabinet

Parameter	Specification
Cores	3 wires + PE, according to IEC 60446
Cross section range	185 mm ² to 240 mm ² (365 kcmil to 474 kcmil)
Conductor	Bare copper, fine wired, bunch stranded, according to VDE 0295 Cl.5/IEC Cl.5
Diameter of the phase conductors	Refer to the local rules.

Parameter	Specification
Insulation	PVC that is serviceable for outdoor use, UV-protected, and oil resistant
Minimum nominal voltage U _o /U	450/750 VAC
Minimum test voltage	4 kV
Ambient temperature range	-40 °C to +80 °C (-40 °F to +176 °F)
Diameter of the PE conductor	The same as the diameter of the phase conductors

12.18.2 DC power installation cables

The below data are specific for the DC power cables between the power cabinet and the charge post.

Parameter	Specification
Type	1x Positive, 1x negative cable Flexible Unshielded
Number of cores	1
Cross section range (minimum)	185 mm ² (365 kcmil)
Cross section range (maximum)	300 mm ² (592 kcmil)
Diameter	27 to 35 mm (1.1 to 1.4 in)
Maximum length	60 m (197 ft)
Conductor	Fine wire, stranded in tin plated copper or aluminum, according to VDE 0295 cl.5/IEC Cl.5
Diameter of the phase conductors	Refer to the local rules.
Insulation	Rubber or PVC that is serviceable for outdoor use, UV-protected, and oil resistant
Nominal voltage U _o (Phase to ground nominal voltage) /U (Phase to phase nominal voltage)	600/1000 Vac - 900/1500 Vdc
Minimum test voltage	6 kV
Ambient temperature range	-40°C to 80°C (-40 °F to 176 °F)
Maximum cable temperature (on the surface)	+90°C (+194 °F)

12.18.3 PE cable

Parameter	Specification
Cores	1 core, gn/ye
Cross section range	35 mm ² (69 kcmil) (2 AWG)
Type	Flexible, unshielded
Diameter	13 - 21 mm
Length	Refer to the local rules.

Parameter	Specification
Conductor	Fine strand copper wire according to VDE 0295 Cl. 5/ IEC 60228 Cl. 5
Insulation	Special PVC that is serviceable for outdoor use, UV-protected, and oil resistant
Minimum nominal voltage U ₀ /U	600/1000 Vac
Minimum test voltage	4 kV
Ambient temperature range	-40°C to 80°C (-40 °F to +176 °F)
Diameter of the PE conductor	The same as the diameter of the phase conductors

12.18.4 AC auxiliary power cables

Parameter	Specification
Number of cores	4
Cross section range	2.5 mm ² (14 AWG)
Shielding	No
Conductor	Bare copper, fine wired, brunch stranded according to VDE 0295 Cl.5/IEC Cl.5
Insulation	Special PVC (that is serviceable for outdoor use, UV-protected, and oil resistant
Minimum nominal voltage (U ₀ /U)	450/750 Vac
Minimum test voltage (AC)	4 kV
Ambient temperature range	-40°C to +80°C (-40 °F to +176 °F)
Core identification	According to IEC 60446
Strip length	11 mm (0.43 in)

12.18.5 Interlock and DC guard cables

Parameter	Specification
Number of cores	2 x 2 twisted pair (4 core)
Diameter (inside)	1.3 to 2.1 mm ² (16 to 14 AWG)
Diameter (outside)	10 to 17 mm (0.39 to 0.67 in)
Shielding	Tinned copper braid Possible configuration: shielded 4 core cable 2 x 2 pairs twisted or two separate shielded dual core cables
Conductor	Fine strand copper wire
Insulation	PVC or other material that is serviceable for outdoor use and UV-protected
Test voltage	1.5 kV
Strip length	11 mm (0.43 in)

12.18.6

Ethernet cable between the power cabinet and the charge post

Parameter	Specification
Type	Shielded (tinned copper braid)
Number of (twisted) pairs	4 x 2
Core identification	Acc. to DIN 47100
Cross section	0.5 - 0.75 mm ²
Diameter	5 - 10mm
Conductor	Fine strand copper wire
Insulation	PVC that is serviceable for outdoor use, UV-protected, and oil resistant
Characteristic impedance	120 Ω ± 10%
Voltage rating	600 VAC
Test voltage	1.5 kV
Ambient temperature range	-40°C to 80°C

12.19 Electrical connection diagram

Site Layout Connections

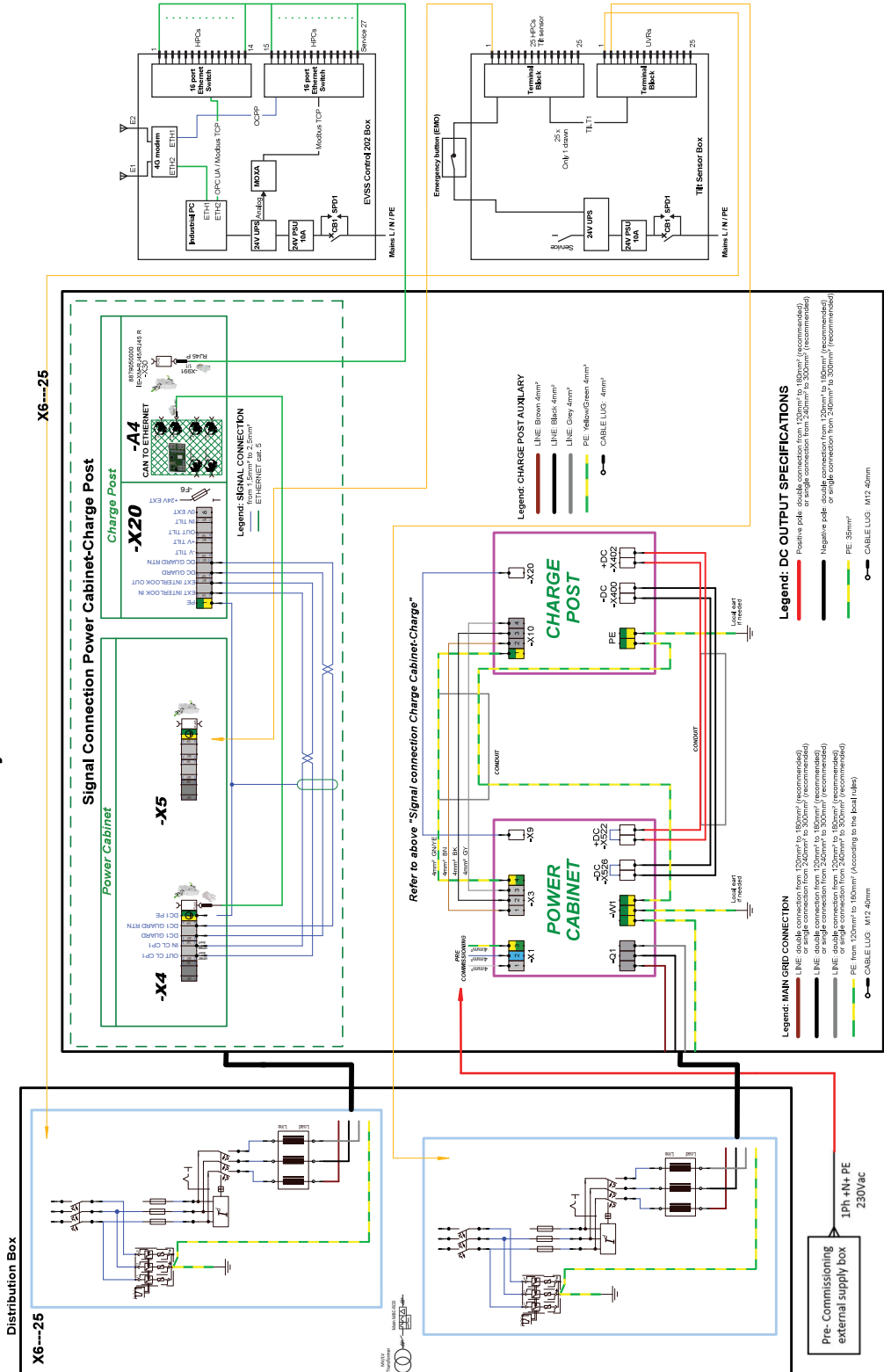

12.20 Expected wye input

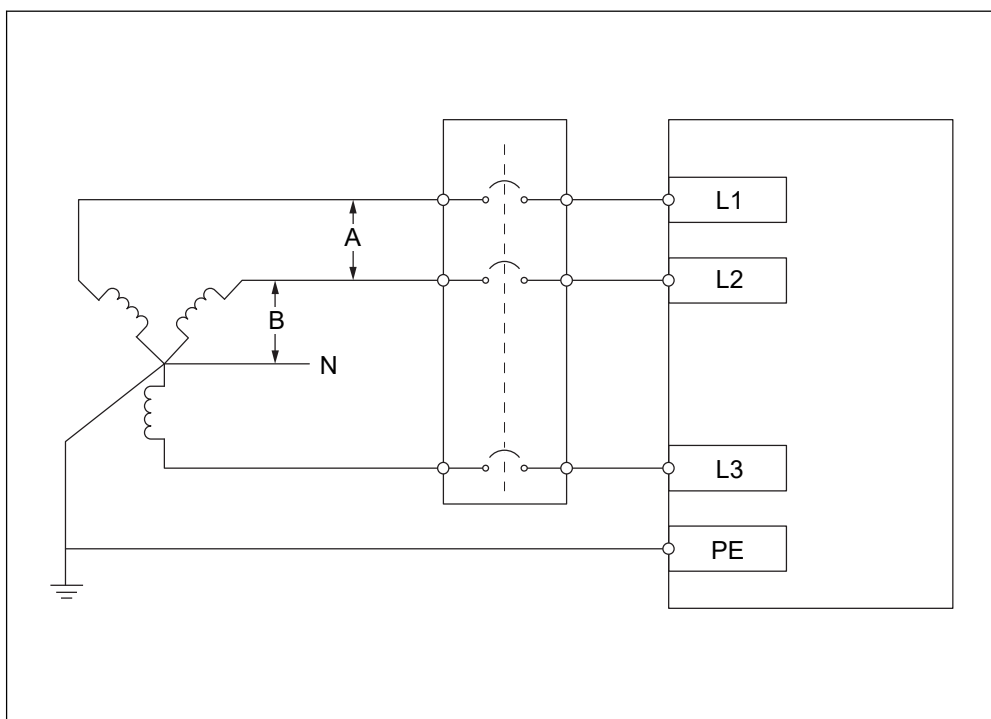

	Canada	USA
A	600 V	480 V
B	347 V	277 V

13

Appendix

13.1

Hinweise zur Messgenauigkeit entsprechend der Baumusterprüfbescheinigung

Hinweise zur Messgenauigkeit entsprechend der Baumusterprüfbescheinigung

I - Anforderungen an den Betreiber des Ladegeräts, die er als Voraussetzung für den ordnungsgemäßen Betrieb des Ladegeräts erfüllen muss. Betreiber der Ladeeinrichtung ist der Benutzer des Messgerätes im Sinne von § 31 des Mess- und Eichgesetzes

1. Die Ladeeinrichtung gilt nur dann als bestimmungsgemäß und eichrechtskonform verwendet, wenn die darin eingebauten Zähler keinen anderen Umgebungsbedingungen ausgesetzt werden als denen, für die ihre Baumusterprüfbescheinigung ausgestellt wurde.
2. Der Nutzer dieses Produktes muss bei der Anmeldung der Ladepunkte bei der Bundesnetzagentur auch die auf dem Ladegerät angegebene PK für die Ladepunkte in dessen Anmeldeformular eintragen! Ohne diese Registrierung ist ein eichrechtskonformer Betrieb des Ladegerätes nicht möglich.

Bitte beachten Sie hierzu folgenden Weblink:

[Bundesnetzagentur - Meldung von Ladepunkten](https://www.bundesnetzagentur.de/DE/Sachgebiete/ElektrizitaetundGas/Unternehmen_Institutionen/E-Mobilitaet/start.html)

https://www.bundesnetzagentur.de/DE/Sachgebiete/ElektrizitaetundGas/Unternehmen_Institutionen/E-Mobilitaet/start.html

3. Der Benutzer dieses Produkts muss sicherstellen, dass die Kalibrierungsgültigkeitszeiträume für die Komponenten im Ladegerät und für das Ladegerät selbst nicht überschritten werden.
4. Der Benutzer muss die vom Ladegerät gelesenen signierten Datenpakete - entsprechend der Paginierung - dauerhaft (auch) auf Hardware speichern, die für diesen Zweck in seinem Besitz ist ("dedizierter Speicher") - und sie verfügbar halten für autorisierte Dritte (betriebliche Verpflichtung des Speichers.). Permanent bedeutet, dass die Daten nicht nur bis zum Abschluss des Geschäftsvorfalles gespeichert werden müssen, sondern zumindest bis zum Ablauf der gesetzlichen Fristen für den Rechtsbehelf für den Geschäftsvorgang. Für nicht vorhandene Daten dürfen zu Abrechnungszwecken keine Ersatzwerte erstellt werden.
5. Der Benutzer dieses Produkts muss den Benutzern von Messwerten, die von ihm Messwerte aus diesem Produkt erhalten, diese zur Verfügung stellen und sie in Geschäftsvorgängen mit einer elektronischen Form von Betriebsanweisungen verwenden, die von der Konformitätsbewertungsstelle genehmigt wurde. Der Benutzer dieses Produkts muss insbesondere auf Nr. II "Anforderungen an den Benutzer an die Messwerte vom Ladegerät" hinweisen.
6. Der Benutzer dieses Produktes ist verpflichtet, gemäß § 32 MessEG (Auszug) zu benachrichtigen: § 32 Meldepflicht (1) Wer neue oder erneuerte Messgeräte einsetzt, muss die zuständige Behörde nach staatlichem Recht spätestens sechs Wochen nach Inbetriebnahme benachrichtigen.
7. Soweit es von den autorisierten Stellen für erforderlich gehalten wird, muss der Messgeräteebenutzer den kompletten Inhalt des dedizierten lokalen Speichers oder des Speichers am CPO mit allen Datenpaketen des Abrechnungszeitraums zur Verfügung stellen.

II - Anforderungen an den Verwender der Messwerte aus dem Ladegerät (EMSP) Der Verwender der Messwerte muss § 33 MessEG beachten

§ 33 MessEG (Zitat)

Gesetz über das Inverkehrbringen und die Bereitstellung von Messgeräten auf dem Markt, ihre Verwendung und Eichung sowie über Fertigpackungen (Mess- und Eichgesetz - MessEG) § 33 Anforderungen an das Verwenden von Messwerten

- (1) Werte für Messgrößen dürfen im geschäftlichen oder amtlichen Verkehr oder bei Messungen im öffentlichen Interesse nur dann angegeben oder verwendet werden, wenn zu ihrer Bestimmung ein Messgerät bestimmungsgemäß verwendet wurde und die Werte auf das jeweilige Messergebnis zurückzuführen sind, soweit in der Rechtsverordnung nach § 41 Nummer 2 nichts anderes bestimmt ist. Andere bundesrechtliche Regelungen, die vergleichbaren Schutzzwecken dienen, sind weiterhin anzuwenden.
- (2) Wer Messwerte verwendet, hat sich im Rahmen seiner Möglichkeiten zu vergewissern, dass das Messgerät die gesetzlichen Anforderungen erfüllt und hat sich von der Person, die das Messgerät verwendet, bestätigen zu lassen, dass sie ihre Verpflichtungen erfüllt.
- (3) Wer Messwerte verwendet, hat
1. dafür zu sorgen, dass Rechnungen, soweit sie auf Messwerten beruhen, von demjenigen, für den die Rechnungen bestimmt sind, in einfacher Weise zur Überprüfung angegebener Messwerte nachvollzogen werden können und
 2. für die in Nummer 1 genannten Zwecke erforderlichenfalls geeignete Hilfsmittel bereitzustellen.

Für den Verwender der Messwerte ergeben sich aus dieser Vorschrift folgende spezifische Verpflichtungen für die eichrechtliche Verwendung von Messwerten:

1. Aus dem Vertrag zwischen EMSP und dem Kunden muss eindeutig hervorgehen, dass nur die Lieferung von elektrischer Energie und nicht die Dauer der Ladedienstleistung Gegenstand des Vertrages ist.
2. Die Zeitstempel auf den Messwerten stammen von einer Uhr im Ladegerät, die nicht nach dem Mess- und Eichrecht zertifiziert ist. Sie dürfen daher nicht zur Bewertung der Messwerte herangezogen werden
3. EMSP muss sicherstellen, dass der Vertrieb der E-Mobilitätsdienstleistung über Ladegeräte erfolgt, die eine Überwachung des laufenden Ladevorgangs ermöglichen, wenn keine entsprechende lokale Anzeige am Ladegerät vorhanden ist. Zumindest zu Beginn und am Ende eines Ladevorgangs müssen die Messwerte in eichrechtlich vertrauenswürdiger Weise für den Kunden verfügbar sein.
4. Der EMSP muss dem Kunden die abrechnungsrelevanten Datenpakete inklusive Signatur als Datei zum Zeitpunkt der Rechnungsstellung so zur Verfügung stellen, dass sie mit der Transparenz- und Anzeigesoftware auf ihre Echtheit überprüft werden können. Sie können über nicht eichrechtlich geprüfte Kanäle zur Verfügung gestellt werden.
5. Der EMSP muss dem Kunden die zum Ladegerät gehörende Transparenz- und Anzeigesoftware zur Überprüfung der Datenpakete auf Integrität zur Verfügung stellen.
6. Der EMSP muss in der Lage sein, nachvollziehbar darzustellen, mit welchem Identifikationsmittel der zu einem bestimmten Messwert gehörende Abrechnungsvorgang eingeleitet wurde. Das heißt, er muss für jeden Geschäftsvorfall und jeden abgerechneten Messwert nachweisen können, dass er die persönlichen Identifikationsdaten korrekt zugeordnet hat. Der EMSP hat seine Kunden über diese Verpflichtung in geeigneter Form zu informieren.

7. Das EMSP darf für Abrechnungszwecke nur Werte verwenden, die in einem beliebigen dedizierten Speicher im Ladegerät und / oder im Speicher des Betreibers des Ladegeräts vorhanden sind. Es dürfen keine Ersatzwerte für Abrechnungszwecke gebildet werden.
8. Der EMSP muss durch entsprechende Vereinbarungen mit dem Betreiber der Abrechnungseinrichtung sicherstellen, dass die zur Abrechnung verwendeten Datenpakete ausreichend lange gespeichert werden, um die zugehörigen Geschäftsvorfälle abwickeln zu können.
9. Der EMSP hat im Falle eines berechtigten Verlangens die Authentifizierung der zu dieser Betriebsanleitung gehörenden Exemplare des Produkts durch Bereitstellung geeigneter Identifikationsmittel zum Zwecke der Durchführung von Kalibrierungen, Diagnoseprüfungen und Maßnahmen der Einsatzüberwachung zu ermöglichen.
10. Alle vorgenannten Verpflichtungen gelten für den EMSP als Messwertnutzer im Sinne des § 33 MessEG auch dann, wenn er die Messwerte über einen Roaming-Dienstleister von den Ladeeinrichtungen bezieht.

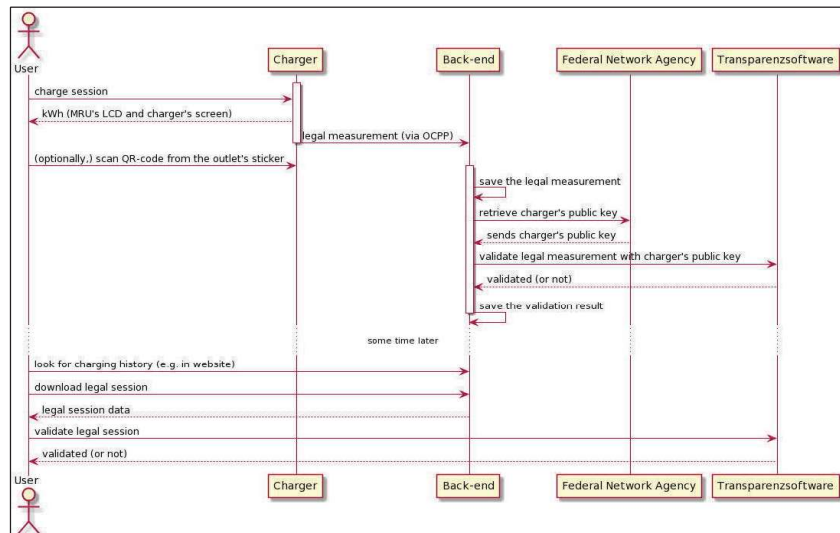

Abbildung 1 – Darstellung der Datensequenz zur Validierung

