

Proposed Window Schedule

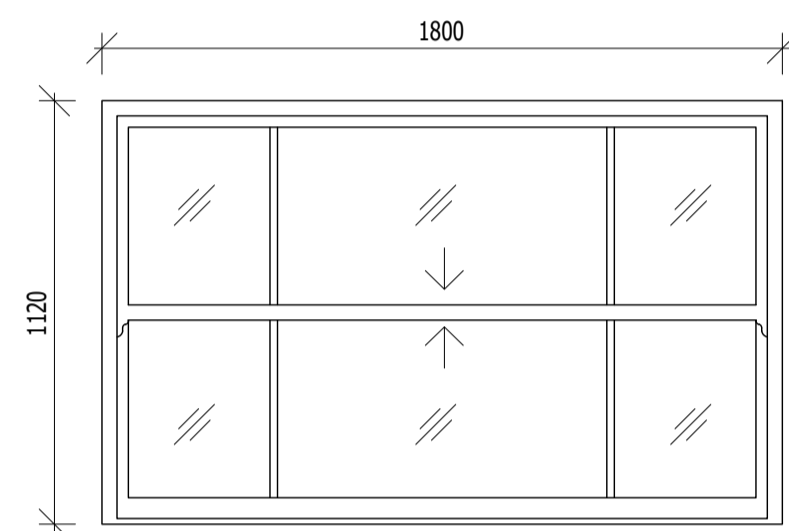

TYPE A - 1no.
New double glazed sliding sash uPVC window
WB.01

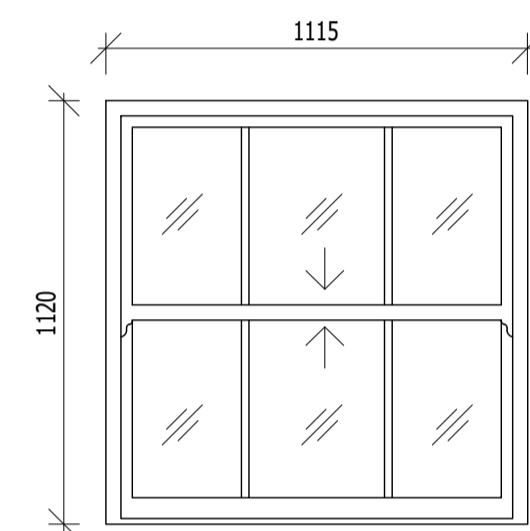

TYPE B - 1no.
New double glazed sliding sash uPVC window
WB.02

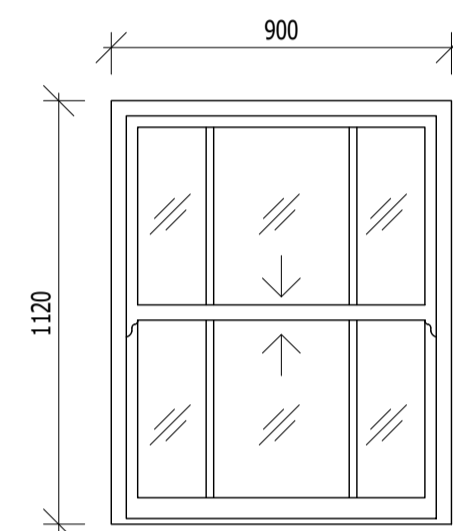

TYPE C - 1no.
New double glazed sliding sash uPVC window
WB.03

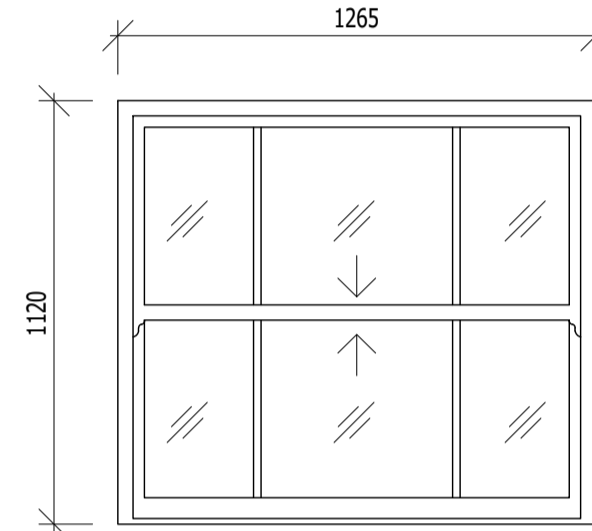

TYPE D - 1no.
New double glazed sliding sash uPVC window
WB.04

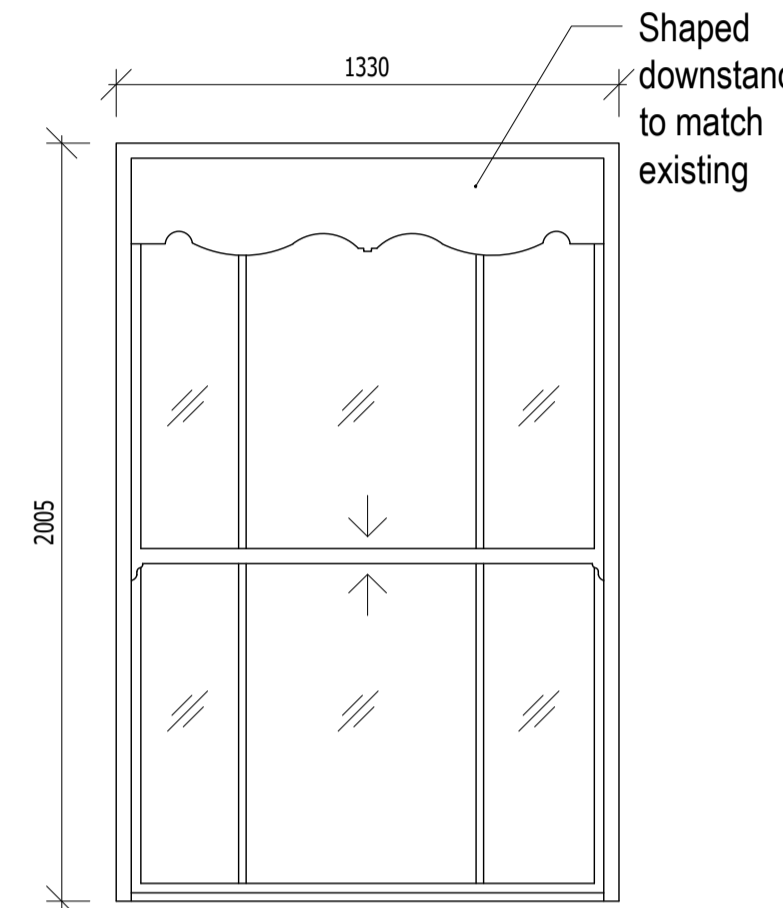

TYPE E - 2no.
New double glazed sliding sash uPVC windows
WG.01, WG.02

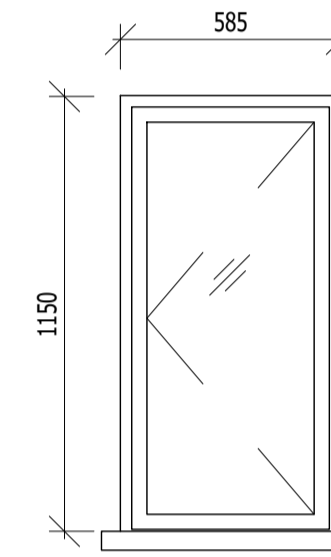

TYPE F - 1no.
New double glazed side hung uPVC window
WG.03

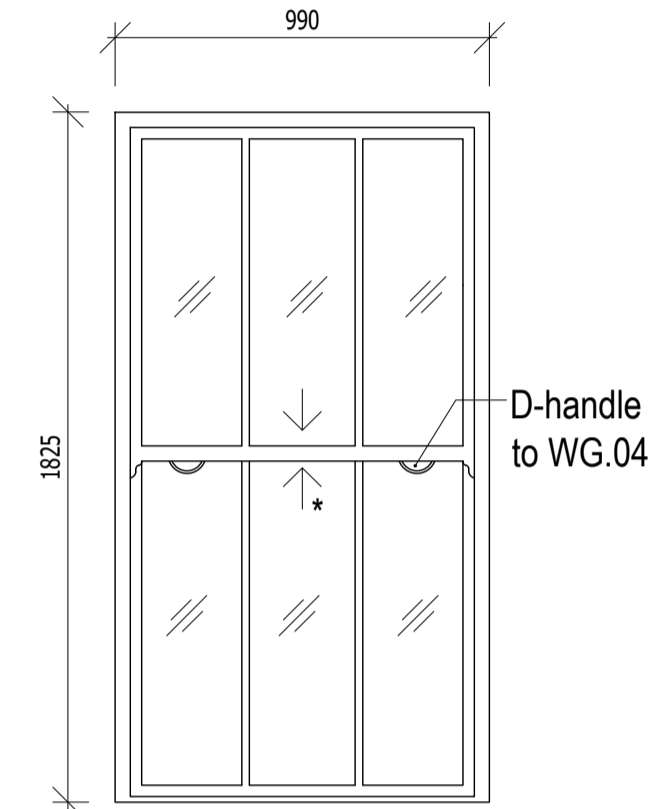

TYPE G - 2no.
New double glazed sliding sash uPVC windows
*Fixed lower sash to WG.04
WG.04 & WG.05

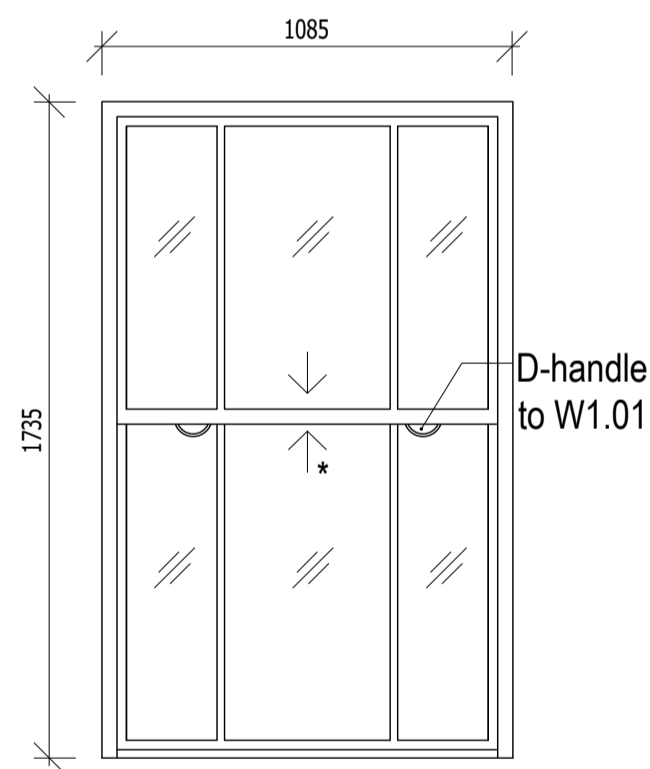

TYPE H - 2no.
New double glazed sliding sash uPVC windows
*Fixed lower sash to W1.01
W1.01 & W1.02

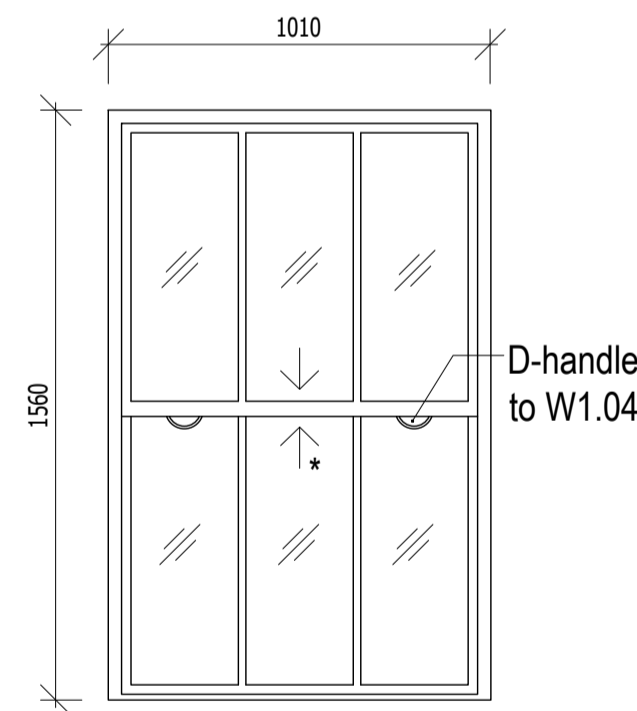

TYPE I - 2no.
New double glazed sliding sash uPVC windows
*Fixed lower sash to W1.04
W1.03 & W1.04

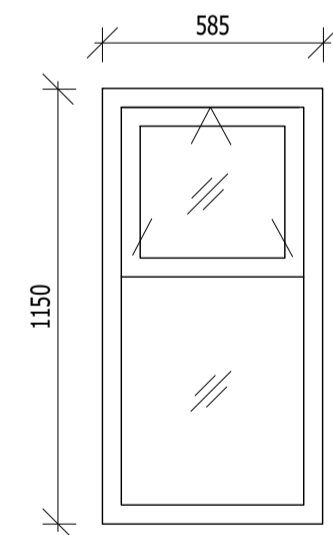

TYPE J - 1no.
New double glazed top hung uPVC window
W1.05

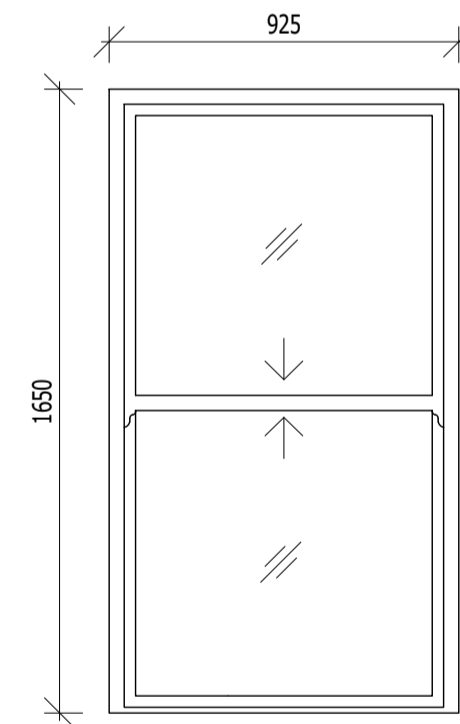

TYPE K - 1no.
New double glazed sliding sash uPVC window
W1.06

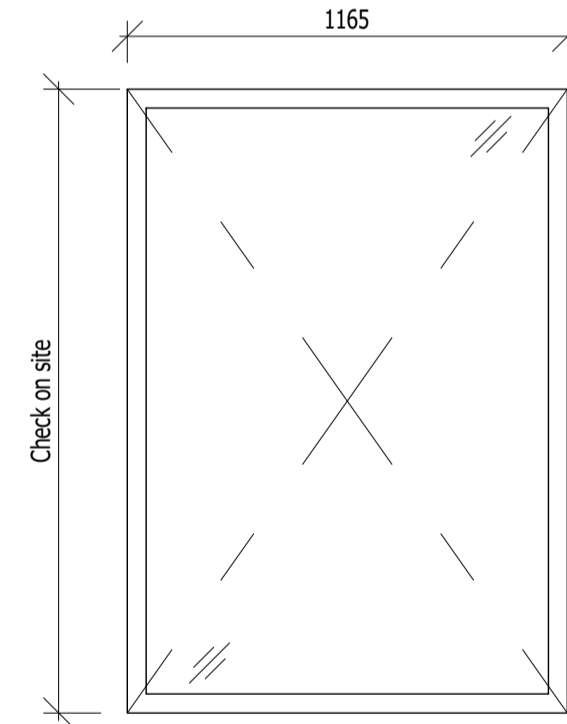

TYPE L - 2no.
New double glazed Velux windows
W2.01 & W2.02

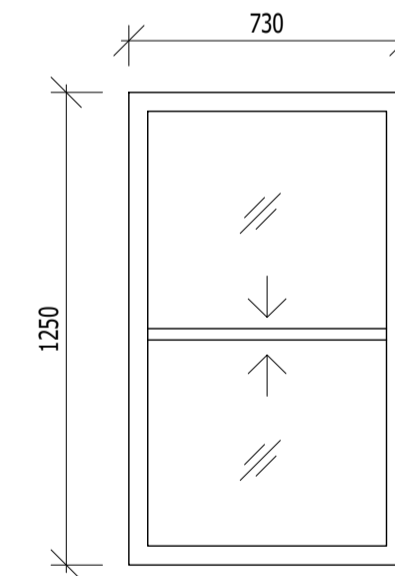

TYPE M - 2no.
New double glazed sliding sash uPVC windows
W2.06 & W2.07

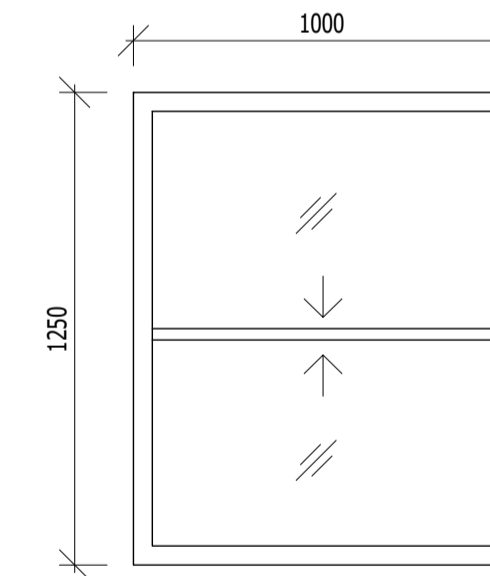

TYPE N - 3no.
New double glazed sliding sash uPVC windows
W2.03, W2.04 & W2.05

Total New Windows: 22no.
Target u-value 1.2 w/m2k
0.39 G value, RW30dBA

Total Windows to front facade to be replaced - 6no.
Target u-value 1.2 w/m2k
0.39 G value, RW30dBA

Notes:

- All window opening dimensions to be checked on site prior ordering

CONSTRUCTION ISSUE

C1	Construction issue	20.09.23
Rev	Description	Date

Client
Kingston University London

Job title
No.71 Penrhyn Road
Kingston Upon Thames
KT1 2EQ

Drawing title
**Window Schedule
As Proposed**

Scale	Date	Drawn
1:20@A1	March 23	TM

ARCHITON LLP
CHARTERED ARCHITECTS · DESIGN · PLANNING CONSULTANTS · DEVELOPMENT · BUILDING COST MANAGEMENT
UPPER DECK 17A WEST STREET EPSOM KT18 7RL
TEL: 01372 745600 FAX: 01372 745016 Email: info@architon.com

Drawing No
3292-131 C1
ARCHITON LLP certified to:
BS EN ISO 9001
BS EN ISO 14001
IIP Accreditation