

TOP VIEW
1:100
A
161632-SQ39264-01

B
161632-SQ39264-01

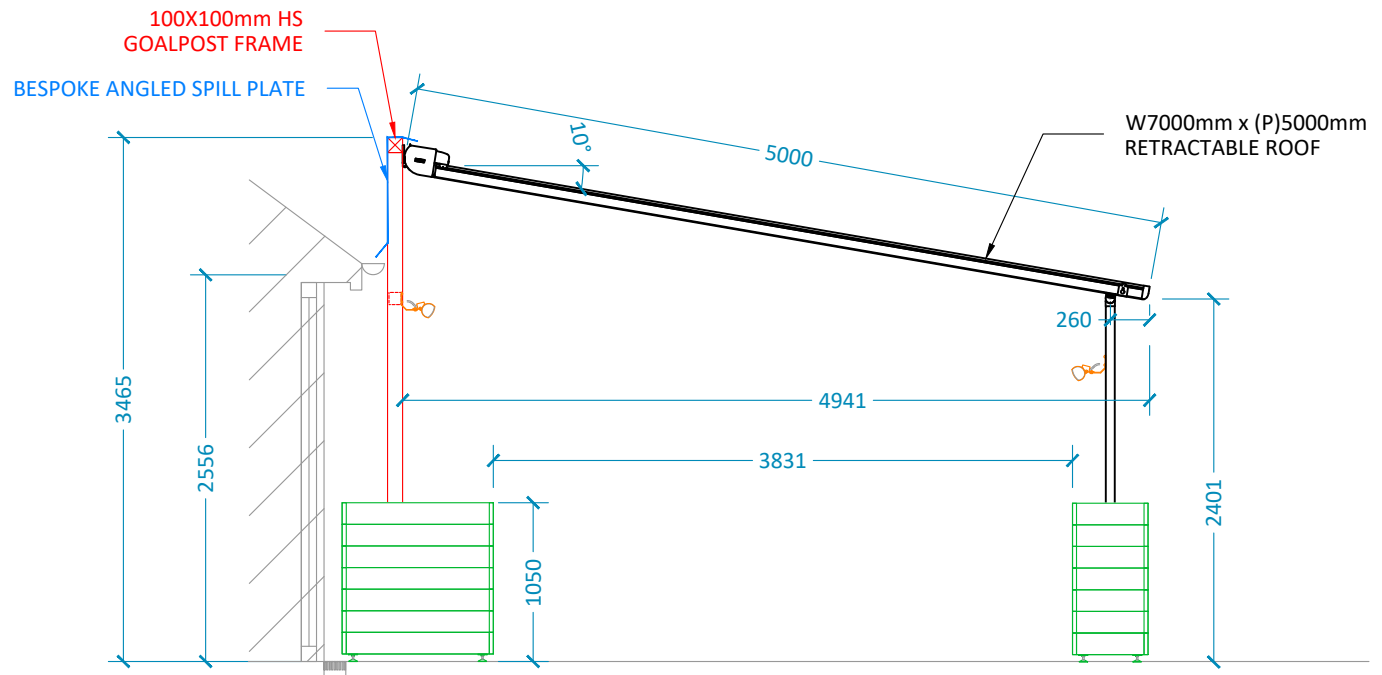

ELEVATION
1:100
B
161632-SQ39264-01

DESIGN SIGN OFF	
AEL ACCOUNT MANGER	
DESIGNER	
CLIENT	

- DRAWING NOTES:**
- 1NO. 7000*(P)5000mm RETRACTABLE ROOF (Pergolino)
 - 10° pitch
 - FRAME - RAL 7016
 - FABRIC ROOF - 42232
 - 2NO. 1000*500*1050mm WEIGHTED PLANTER
 - 3NO. 1500*500*1050mm WEIGHTED PLANTER
 - 6 No. 1.65 kW INFRARED HEATERS

WEATHERING TO BUILDING, FOOTINGS, ELECTRIC SUPPLY & FINAL CONNECTION BY OTHERS

GOOD ACCESS

DRAWING DISCLAIMERS:
 • DO NOT SCALE. DRAWINGS ARE INDICATIVE FOR VISUAL REPRESENTATION ONLY AND MAY BE USED FOR REFERENCE PURPOSES ONLY. ALL CONTRACTORS ARE RESPONSIBLE FOR TAKING AND CHECKING ALL DIMENSIONS. AEL SOLUTIONS MUST BE NOTIFIED OF ANY DISCREPANCIES IN WRITING.
 • ANY STRUCTURAL WORK MUST BE CARRIED OUT TO THE EXACT SPECIFICATION AND REQUIREMENTS OF THE CLIENT'S APPOINTED STRUCTURAL ENGINEER, AND ANY AMENDMENTS MUST HAVE THEIR EXPRESS PRIOR WRITTEN AUTHORITY. AEL SOLUTIONS ARE NOT RESPONSIBLE FOR ANY COSTS INCURRED BY FAILING TO DO SO.
 • IT IS THE RESPONSIBILITY OF THE CLIENT OR THEIR APPOINTED REPRESENTATIVE TO OBTAIN ANY AND ALL RELEVANT PERMISSIONS FOR THE COMPLETION OF WORKS. AEL SOLUTIONS ARE NOT RESPONSIBLE FOR ANY COSTS INCURRED BY FAILING TO DO SO.
 • ANY DISCREPANCIES BETWEEN DRAWINGS SHOULD BE REPORTED TO AEL SOLUTIONS IN WRITING PRIOR TO COMMENCEMENT OF ANY WORKS.

REV NO.	DATE	DESCRIPTION	DRAWN
03	13/02/2024	Pitch and height change	DT
02	06/02/2024	Pergolino Pitch reduced	DT
01	02/02/2024	Structure change to Pergolino	DT
00	16/01/2024	FIRST ISSUE	KW

JOB TITLE:
MITCHELLS & BUTLERS
ASHTON
BRISTOL

DRAWING TITLE:
PLANTER & SCREEN PROPOSAL LAYOUT

DATE: 13/02/2024	DRAWING NO: 161632-SQ39264-01
DRAWN BY: KW/DT	REVISION NO: 03

AEL
OUTDOOR SOLUTIONS

A&E LEISURE LTD
UNIT G READING APPROACH
15 CRADOCK ROAD
READING RG2 0EE
T 0118 9230300
E sales@aelsolutions.com
www.aelsolutions.com