

GROUND BEAM LAYOUT FOR UNITS 1 AND 2 (1:50)

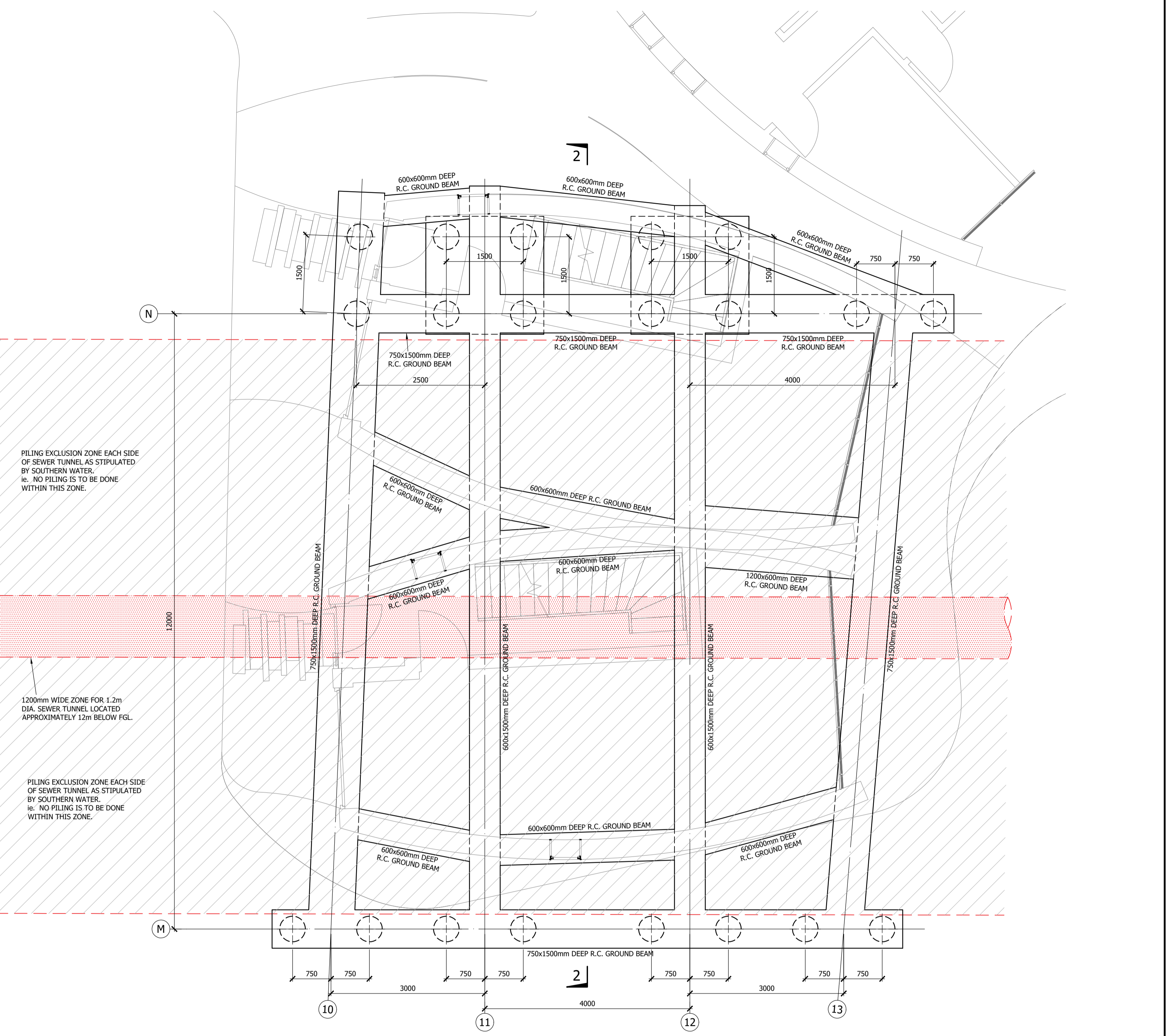

GROUND BEAM LAYOUT FOR UNITS 7 AND 8 (1:50)

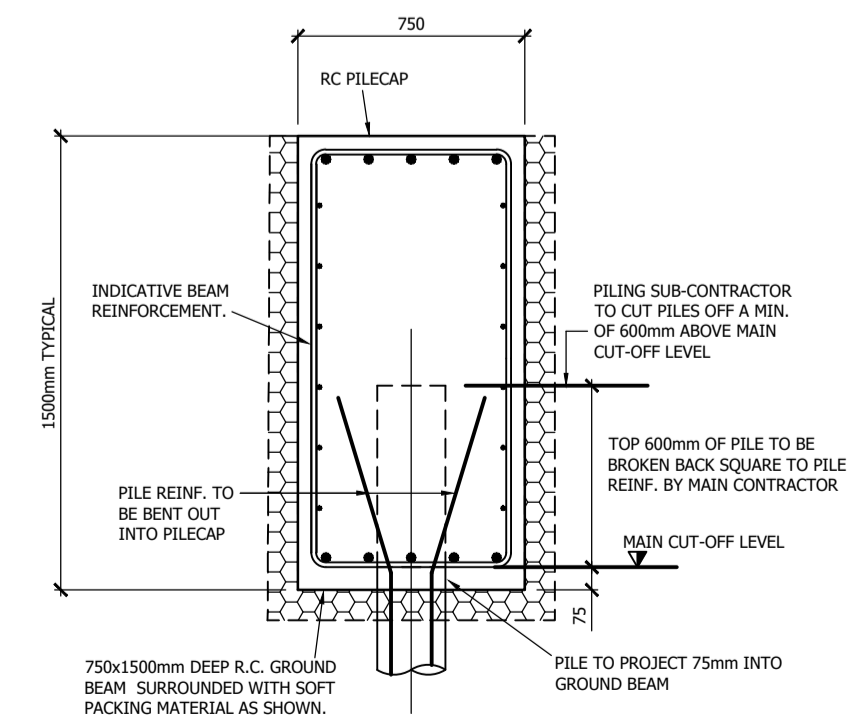

PILE CUT-OFF DETAIL (1:25)

PILING EXCLUSION ZONE EACH SIDE OF SEWER TUNNEL AS STIPULATED BY SOUTHERN WATER. ie. NO PILING IS TO BE DONE WITHIN THIS ZONE.

1200mm WIDE ZONE FOR 1.2m DIA. SEWER TUNNEL LOCATED APPROXIMATELY 12m BELOW FGL.

PILING EXCLUSION ZONE EACH SIDE OF SEWER TUNNEL AS STIPULATED BY SOUTHERN WATER. ie. NO PILING IS TO BE DONE WITHIN THIS ZONE.

INDICATES TYPICAL 500mm DIA. PILES (WITH MAX S.W.L. OF 300 kN).

Rev	Date	Description
Client Quantum Homes		
Project Garden Street, Lewes.		
Drawing Title Foundation General Arrangement.		
Issued for Information		
Brighton: 01273 617117 Belfast: 028 9028 3060 solutions@haworthmccall.co.uk www.haworthmccall.co.uk		
Scale 1:50	Designer T.H.	Date Feb-19
Original paper size A1	Drawn R.O.	Drig No 1037/ 303
		Rev -