

CLOSE BOARDED FENCE TO REFUSE/RECYCLING AREA

NORTH EAST ELEVATION

SOUTH EAST

NORTH WEST

scale 1:50

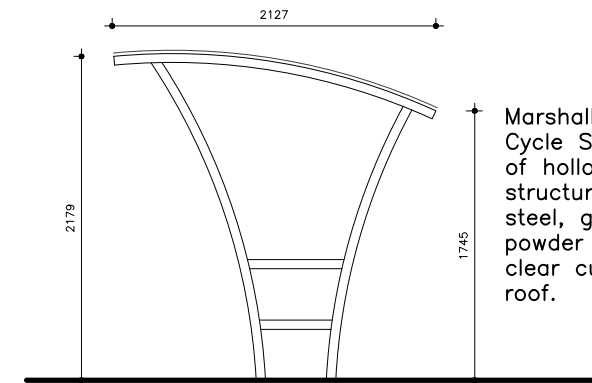

Marshalls Pluto Steel Cycle Shelter comprising of hollow box section structural grade mild steel, galvanised and powder coated with PET clear curved cladding to roof.



CYCLE SHELTER

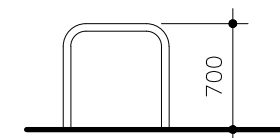

Colour coated steel Sheffield cycle stand or equal. Minimum 800mm clear space between each cycle stand



CYCLE STANDS



Dixon Dawson Chartered Architects
28 Kenwood Park Road
Nether Edge
Sheffield
S7 1NF
T 0114 2683888
E sheffield@dixondawson.co.uk

planning issue

Do not scale. All setting out dimensions to be site confirmed prior to works commencing and any discrepancies confirmed to architect. This drawing is to be read in conjunction with all other architectural and structural engineers drawings.

REVISION A : 28 MARCH 2024 : ELEVATIONS NOTED TO PROPOSED REFUSE STORE TO PLANNING REQUIREMENTS.

GDD

PROPOSED VALET BAY, WASH BAY CANOPIES AND RAMP
LOCKOFORD LANE, CHESTERFIELD, S41 7HY
for VERTU MOTORS (PROPERTY) LIMITED

STREET FURNITURE 1:50@A4

Date:
21/03/24

Drawn:
AW

Checked:

8727s/PA58A