

EXISTING SECTION A-A 1:50

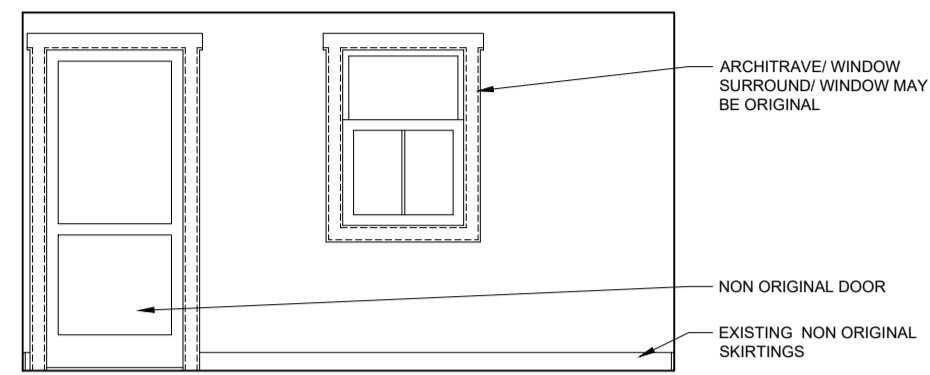

EXISTING SECTION B-B 1:50

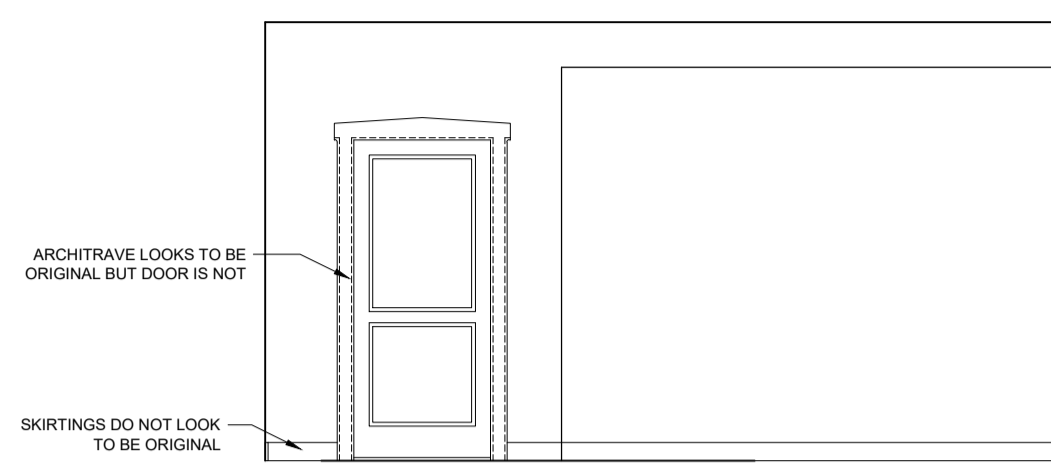

EXISTING SECTION C-C 1:50

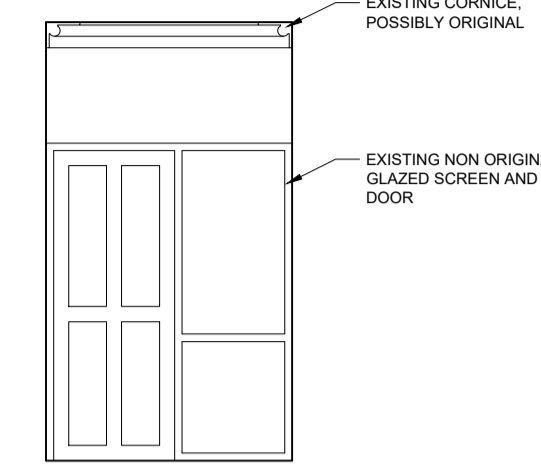

EXISTING SECTION D-D 1:50

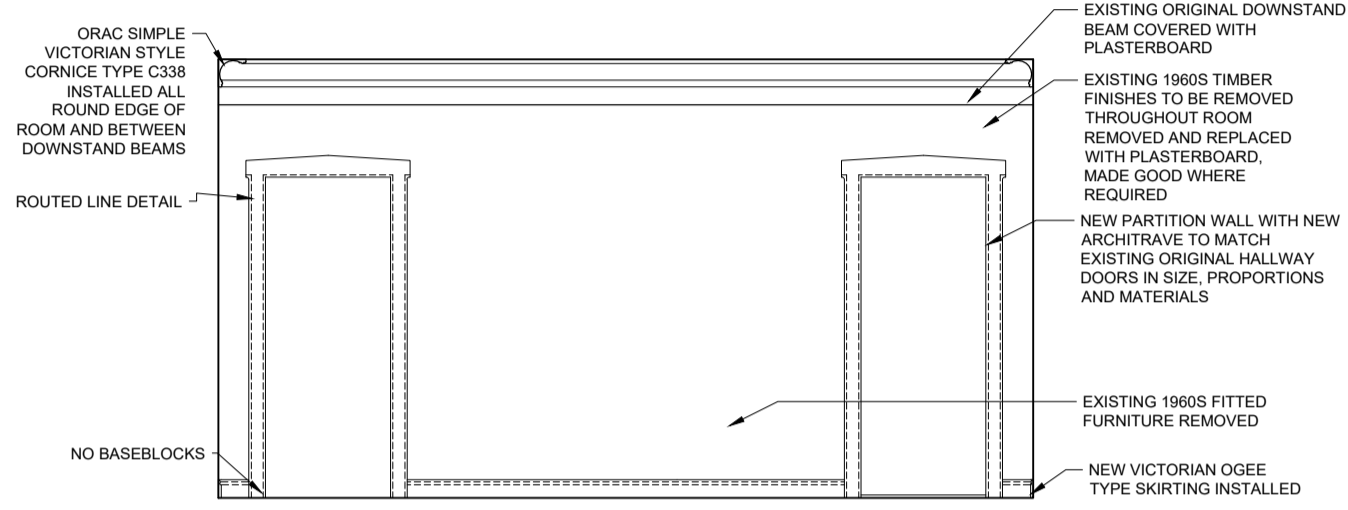

PROPOSED SECTION A-A 1:50

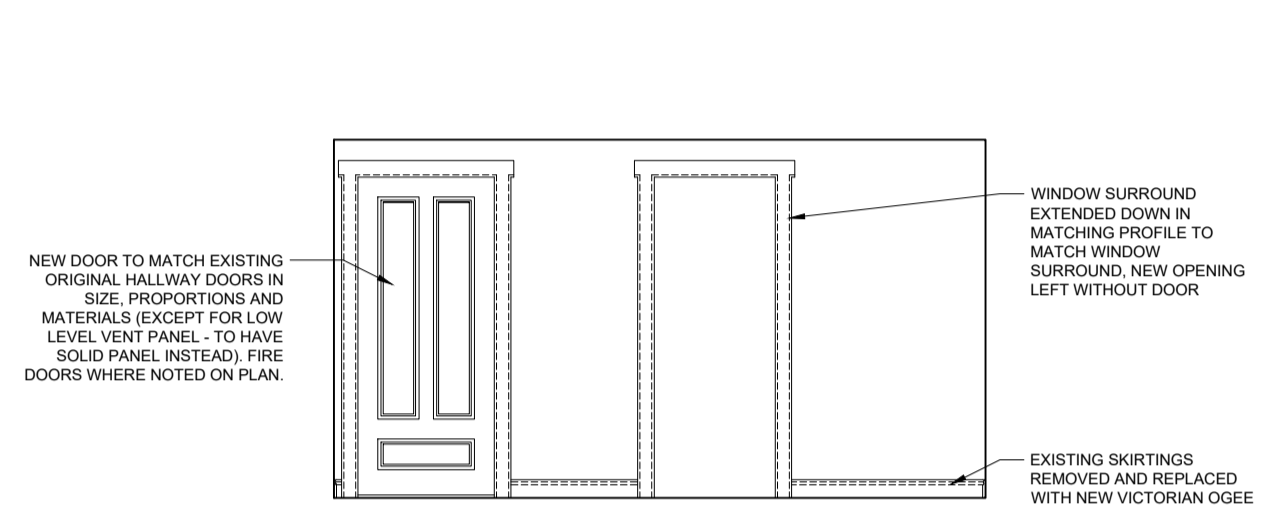

PROPOSED SECTION B-B 1:50

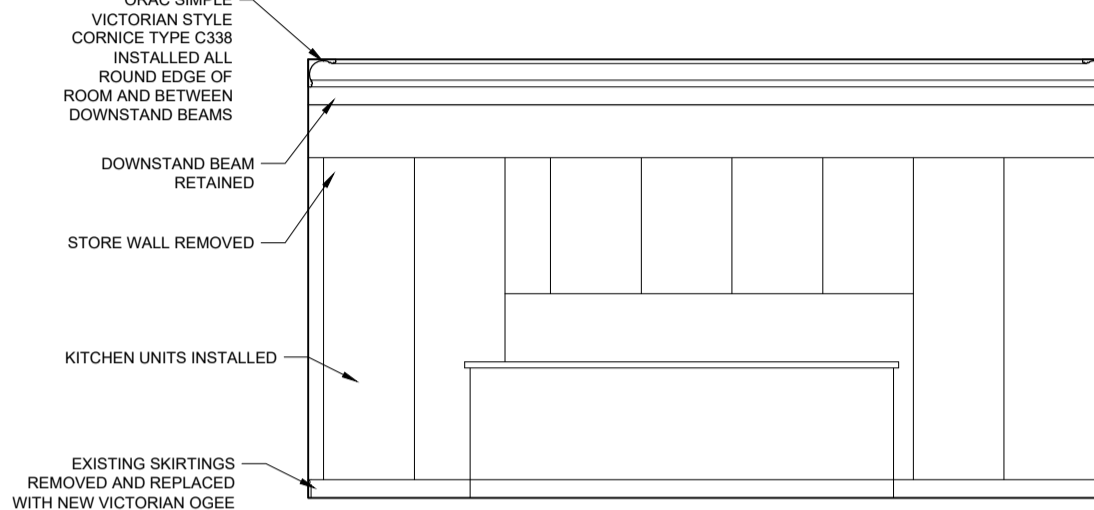

PROPOSED SECTION C-C 1:50

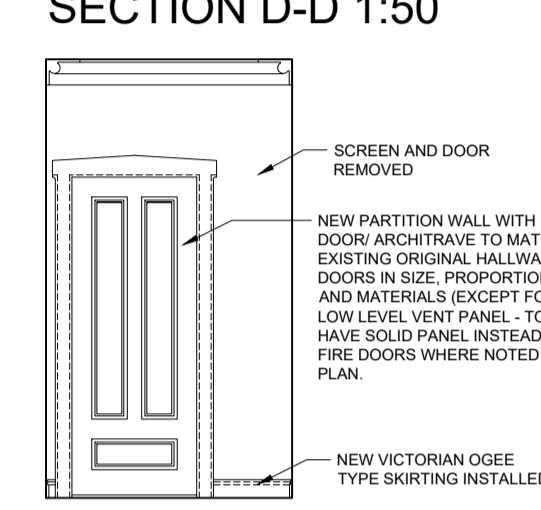

PROPOSED SECTION D-D 1:50

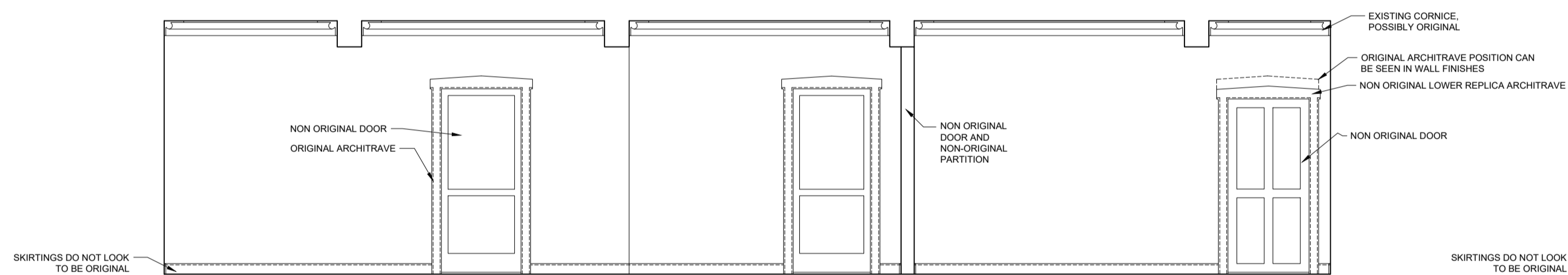

EXISTING SECTION E-E 1:50

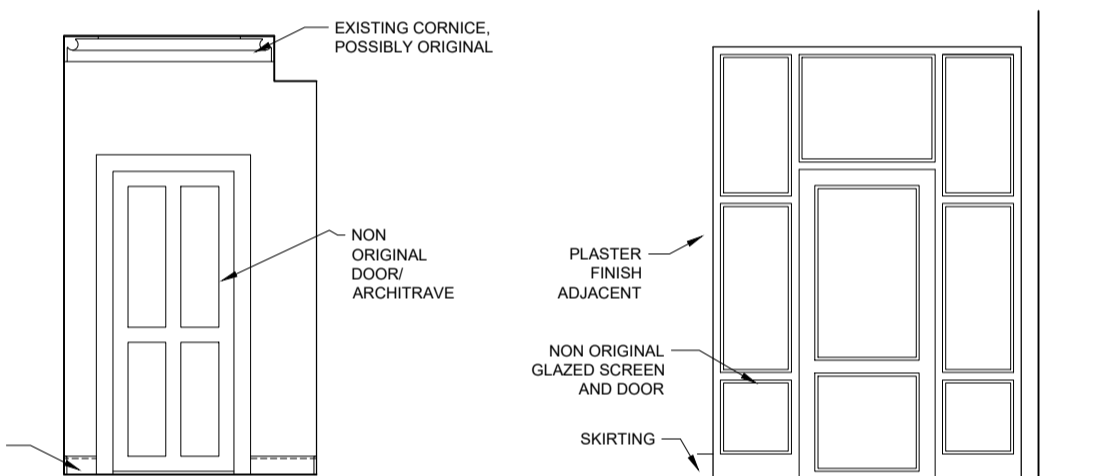

EXISTING SECTION F-F 1:50

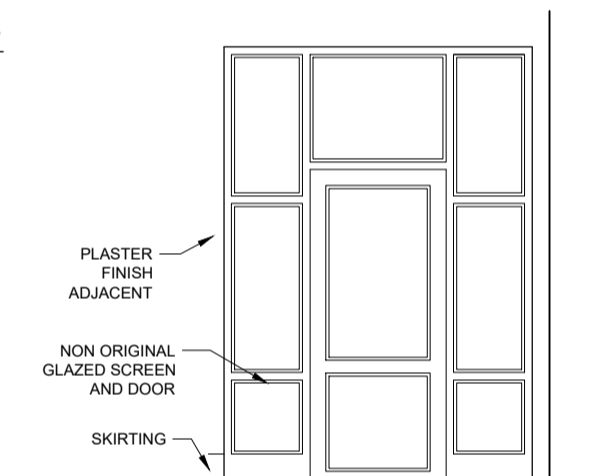

EXISTING SECTION G-G 1:50

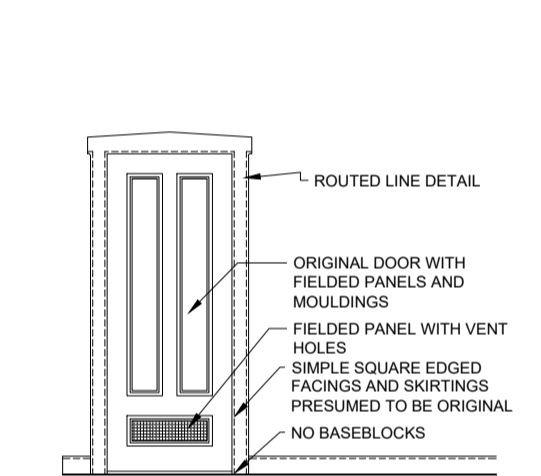

EXISTING ELEVATION OF ORIGINAL HALL DOORS 1:50

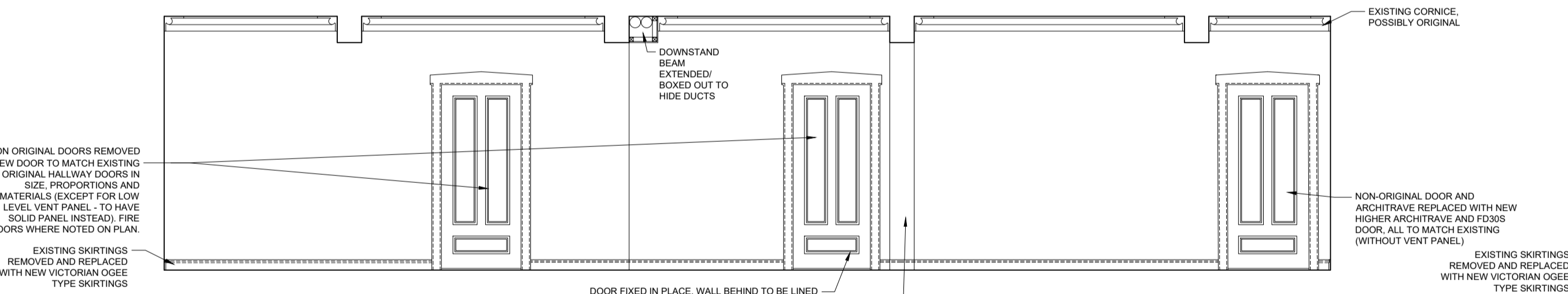

PROPOSED SECTION E-E 1:50

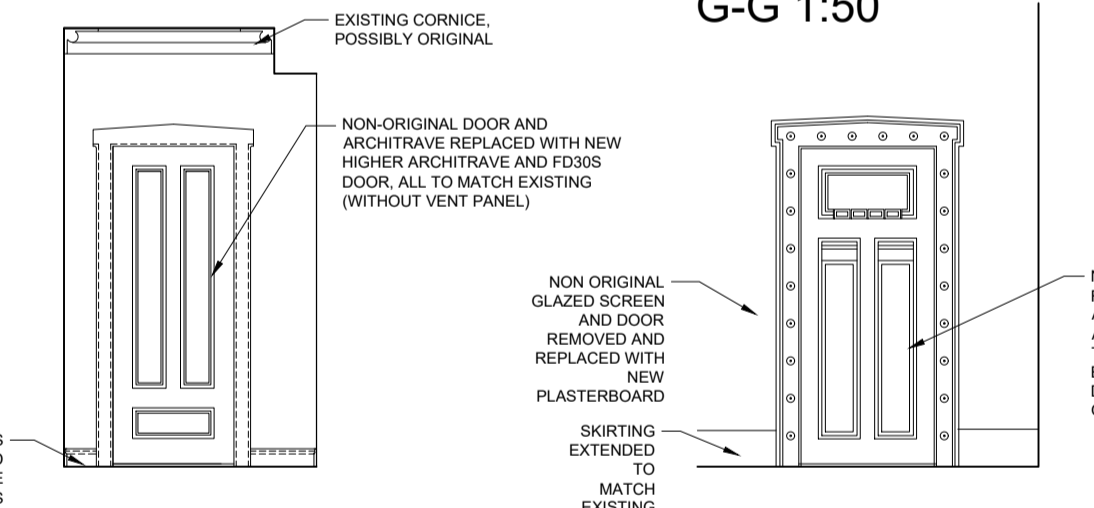

PROPOSED SECTION F-F 1:50

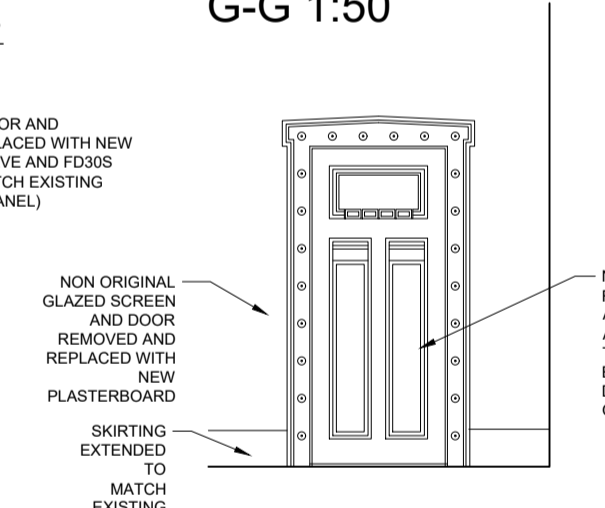

PROPOSED SECTION G-G 1:50

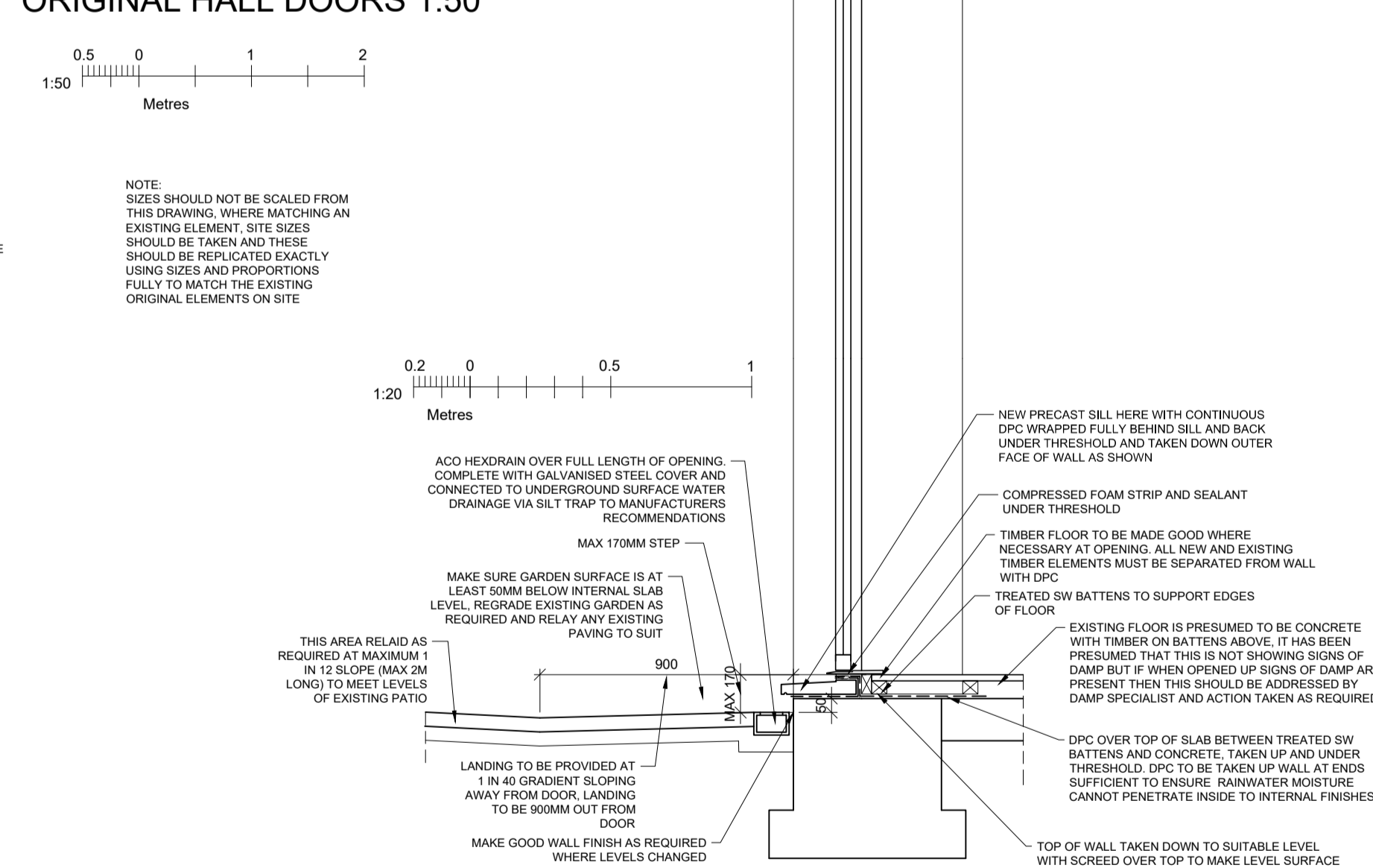

PROPOSED SECTION THROUGH NEW EXT DOOR 1:20