

KEY

1. Curtain wall glazing
2. Granite cladding
3. Anodised aluminium cladding
4. Service louvres
5. Punched windows
6. Metal balustrading
7. Standing seam metal cladding
8. Existing signage

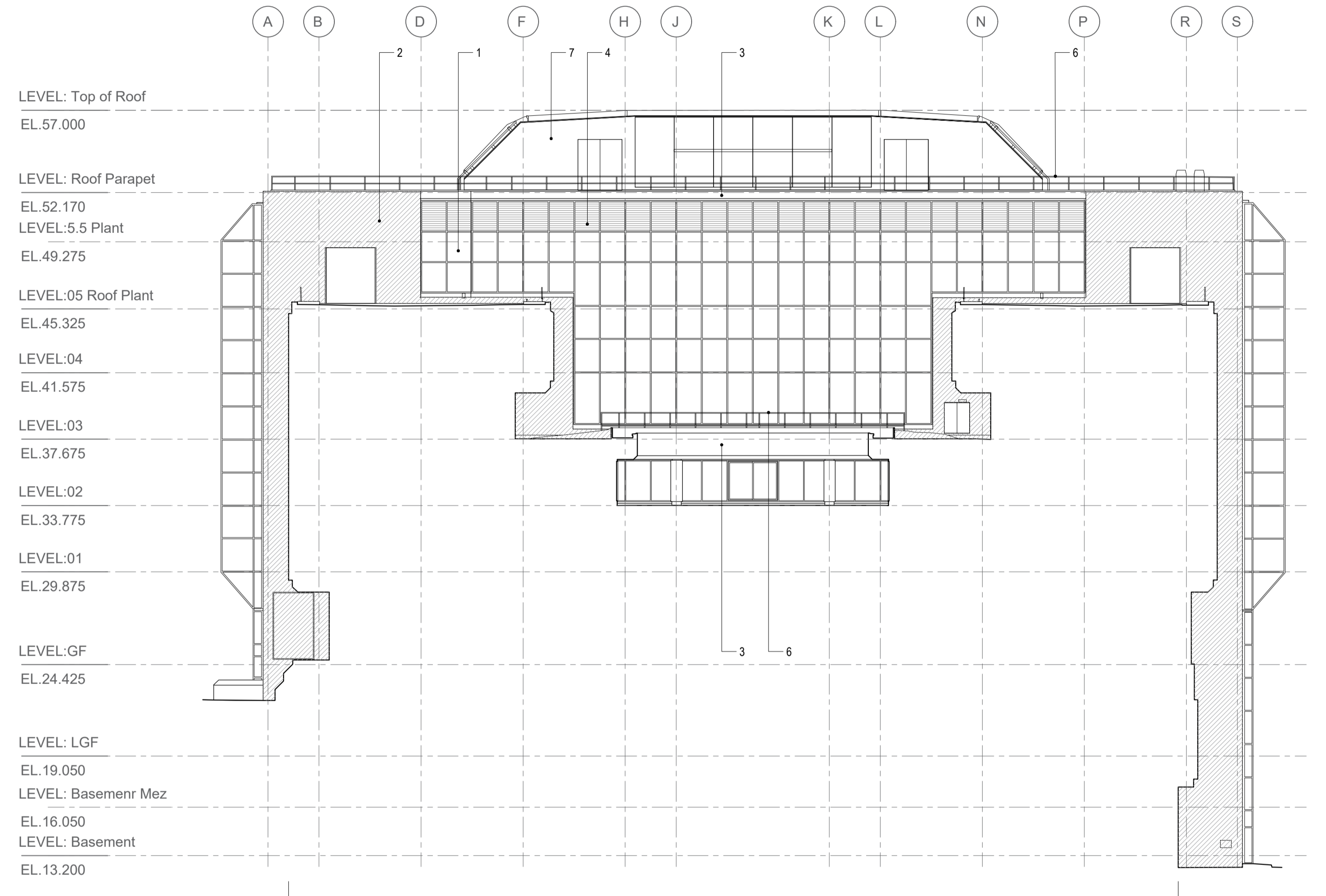
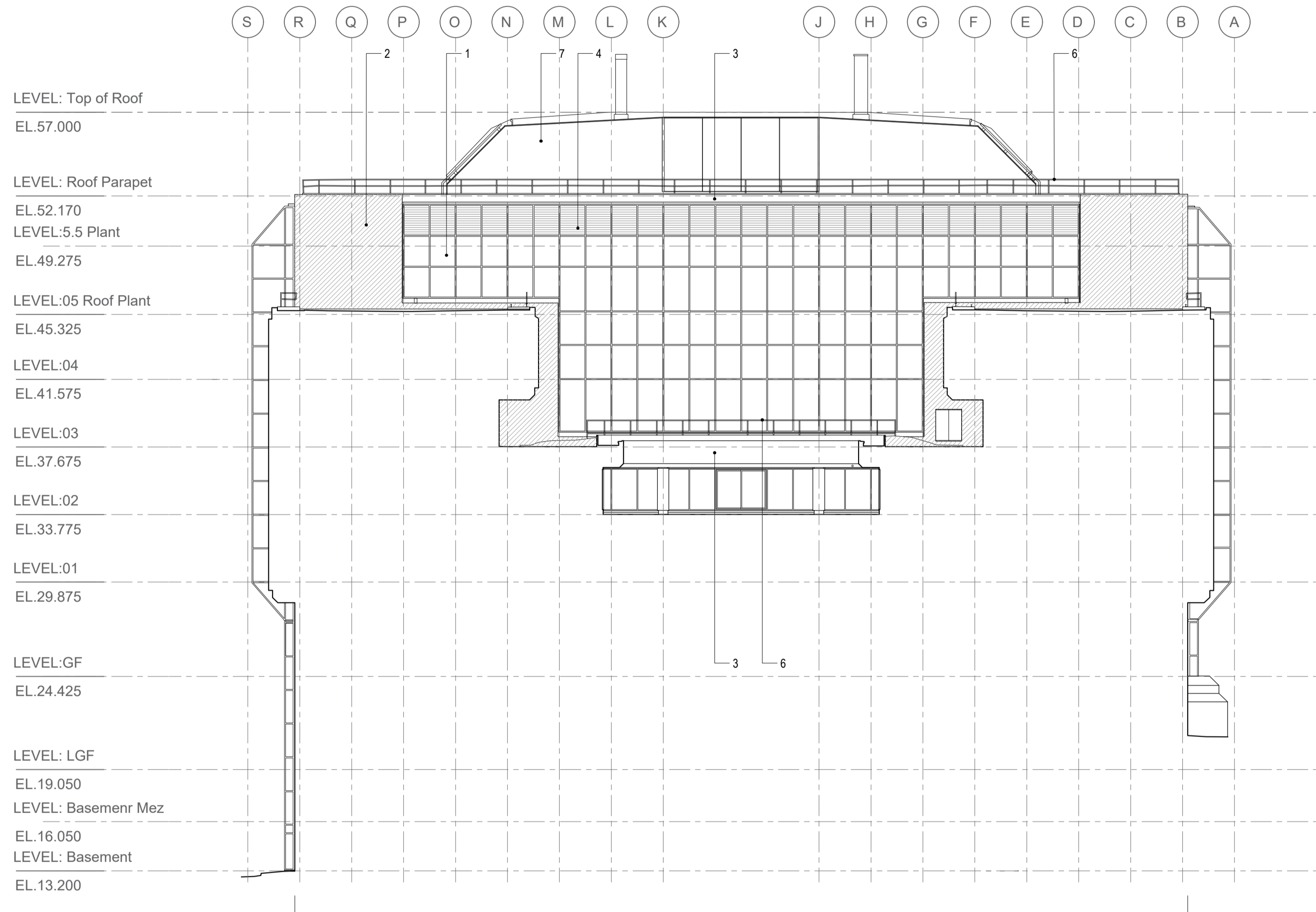
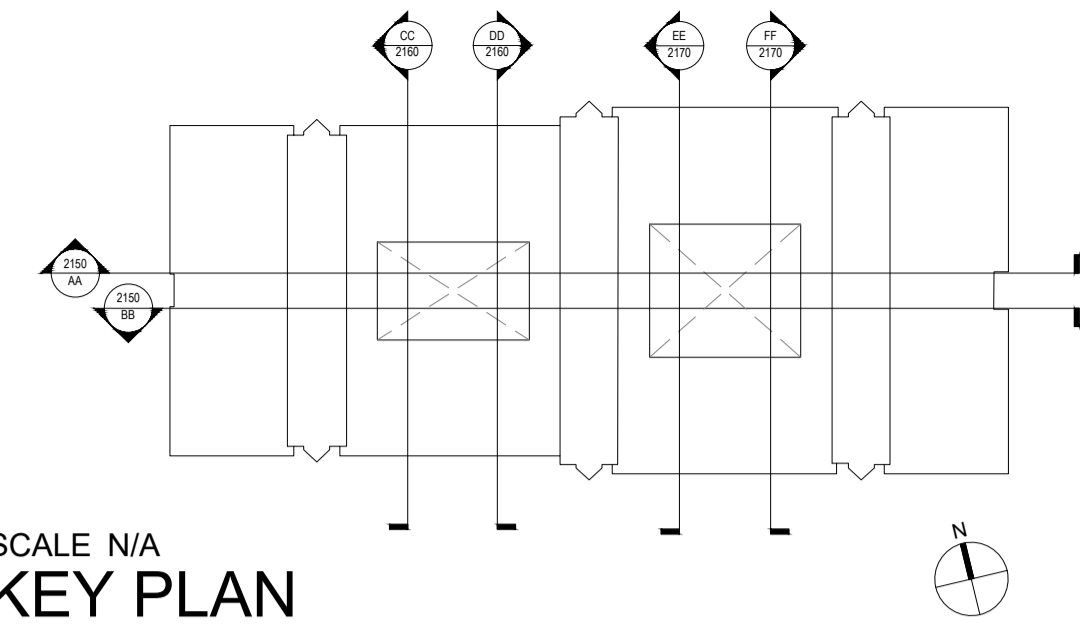

SCALE 1:200
SECTION CC
EXISTING COURTYARD ELEVATIONS

SCALE 1:200
SECTION DD
EXISTING COURTYARD ELEVATIONS

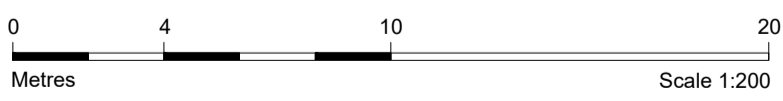

NOTES

- Drawings are design intent and subject to further design development and coordination with engineering and landscape consultant's information.
- Internal configurations of meeting, event and other building amenity spaces are subject to further design development and are shown for indicatively purposes only.
- All furniture indicated is indicative for space planning purposes only.
- Elevations are based on survey information provided by a third party.
- Full survey information is required for basement, car park mezzanine, lower ground floor, ground floor, L1, L3 and L4. Internal layouts may be subject to change.
- Building stacking and letting configuration subject to further development. Floor entrances, WC configurations and access arrangements may be subject to change.

USE OF DRAWINGS

DO NOT SCALE FROM THIS DRAWING. USE WRITTEN DIMENSIONS AND CHECK ON SITE. THIS DRAWING IS BASED ON SITE INFORMATION SUPPLIED BY THIRD PARTIES AND ACCURACY OF EXISTING FEATURES IS NOT GUARANTEED. ANY ERROR, OMISSION OR DISCREPANCY NOTED ON OR BETWEEN DRAWINGS AND OTHER DOCUMENTS MUST BE REPORTED IN WRITING IMMEDIATELY. ALL MECHANICAL, ELECTRICAL AND STRUCTURAL LAYOUTS / COMPONENTS ARE INDICATIVE AND MUST BE DESIGNED AND CHECKED BY SPECIALISTS. DO NOT START WORK ON SITE BEFORE CONFIRMING THAT ALL NECESSARY STATUTORY AND OTHER CONSENTS HAVE BEEN OBTAINED. THIS DRAWING IS COPYRIGHT AND MUST NOT BE DISTRIBUTED WITHOUT PERMISSION. ELECTRONIC CAD FILES MUST NOT BE ALTERED OR COPIED.

REVISIONS

REV	DATE	DESCRIPTION
-	24.03.01	PLANNING ISSUE

CHECKED
DRAWN
MB CP

client OSBORNE+CO ON BEHALF OF SANTANDER	project 301 ST. VINCENT STREET GLASGOW	project number 2088	
sheet size A1	scale 1:200 @ A1	drawing title EXISTING COURTYARD ELEVATION CC & DD	
status PLANNING	approved by	drawing no. 2088-A-P0260	revision
			LOM architecture and design The Glass House 5 Sclater Street London E1 6JY UK Tel +44(0)20 8444 2999 Email mail@lom-fdp.com Web www.lom-architecture.com