

ELEVATION

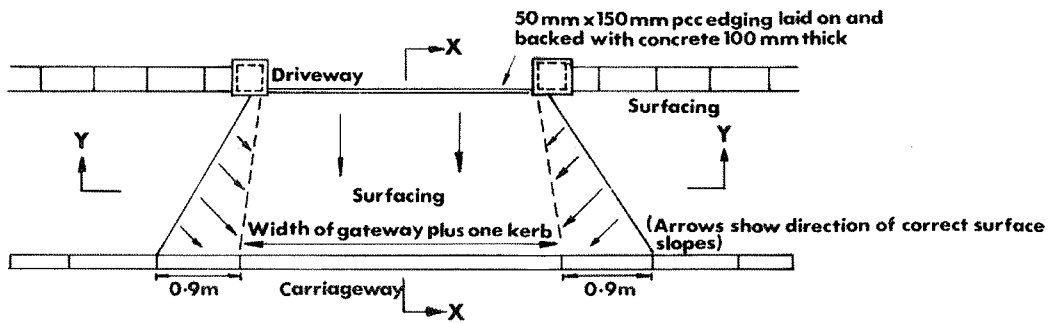

PLAN

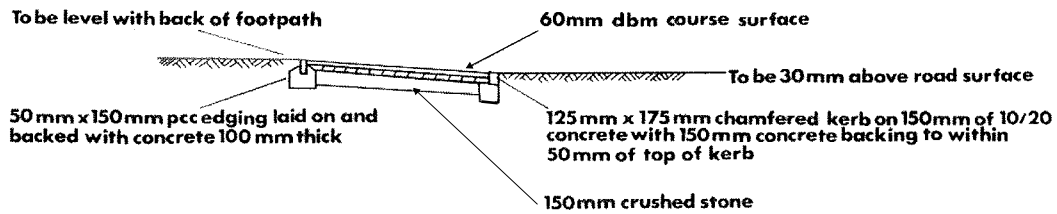

SECTION AT X-X

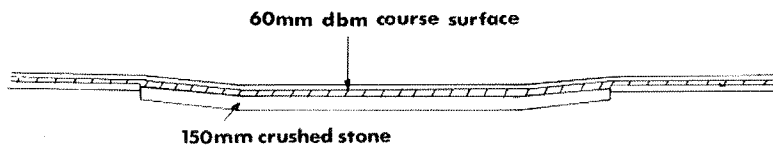

SECTION AT Y-Y



**VEHICULAR CROSSINGS OF VERGES AND FOOTWAYS
 – PRIVATE CARS FLEXIBLE SURFACING
 Drawing Number: SD/VXING/01**