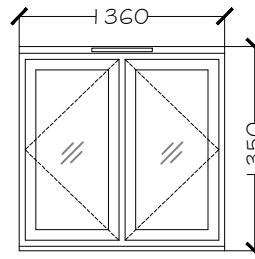
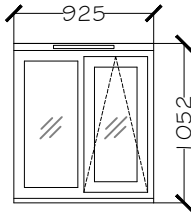
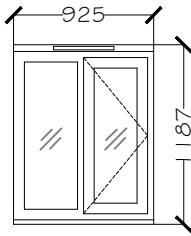
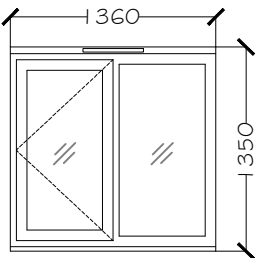
	Window Ref: W1
	Quantity: 1
	Material: PVCu
	Type: Casement
	Size: to match existing opening
	Colour: White

	Window Ref: W4
	Quantity: 1
	Material: PVCu
	Type: Casement
	Size: to match existing opening
	Colour: White

	Window Ref: W1a
	Quantity: 1
	Material: PVCu
	Type: Casement
	Size: to match existing opening
	Colour: White

	Window Ref: W2
	Quantity: 1
	Material: PVCu
	Type: Casement
	Size: to match existing opening
	Colour: White

	Window Ref: W3
	Quantity: 1
	Material: PVCu
	Type: Casement
	Size: to match existing opening
	Colour: White

- This drawing is for Planning Application purposes only
- All critical dimensions to be verified on site.
- Any discrepancies are to be notified to Podium Surveying LLP immediately.
- This document is copyright of Podium Surveying LLP.
- To be read in conjunction with written window specification and details.

- All windows will be double glazed uPVC and incorporate trickle vents.

Proposed window and door schedule
Scale 1:50 @ A3

Ref: 2370-PA-1MW-WS

1 Michaels Walk
Market Harborough
Leicestershire
LE16 8TR

Client: Anglian

Drawn by: SH
Date: March 2024

Podium Surveying LLP
Unit 307
The Biscuit Factory
Drummond Road
London
SE16 4DG

Tel: 0203 142 6674
Mob: 07753 496 220
Email: sheer@podiumllp.com
Web: www.podiumllp.com



- Indicative window and door structural openings shown only.
- Existing structural opening sizes to be confirmed on site.
- Dimensions in millimetres unless stated otherwise

