

## GENERAL NOTES:

THIS DRAWING HAS BEEN PREPARED BY A FULL TIME REGISTERED ARCHITECT AND THEREFORE ALL WORKS CARRIED OUT MUST COMPLY WITH THE CURRENT BUILDING REGULATIONS APPROVED DOCUMENTS AND TO THE SATISFACTION OF THE LOCAL AUTHORITY BUILDING CONTROL OFFICER UNLESS A FURTHER PARTIAL RELIEF PERMISSION IS GRANTED BY THE COUNCIL.

ALL MATERIALS AND COMPONENTS MUST BE SUITABLE FOR THEIR INTENDED PURPOSE AND LOCATION AND MUST BE MANUFACTURED AND INSTALLED IN ACCORDANCE WITH ALL RELEVANT BUILDING REGULATIONS AND CODES OF PRACTICE. THIS REQUIREMENT INCLUDES RELEVANT MANUFACTURER SPECIFICATIONS.

ALL DRAWINGS TO BE CHECKED ON THE PROJECT COMMENCEMENT OF ANY WORK ON THE DRAWINGS, FLOOR AND FOUNDATION LEVEL, AND INDICATED 'OK' AND TO BE COMBINED BY CONTRACTOR ON SITE.

THIS PLAN AND SPECIFICATIONS TO ANY STRUCTURAL, ESTIMATE AND SERVICE ELEMENTS ARE INDICATIVE ONLY. SEE STRUCTURAL ENGINEER/SERVICES ENGINEER DRAWINGS FOR ACTUAL SPECIFICATIONS.

THIS DRAWING IS TO BE READ IN CONJUNCTION WITH ALL OTHER ARCHITECT'S DRAWINGS, SPECIFICATIONS AND OTHER CONSULTANT'S INFORMATION.

ALL PROPOSED ITEMS SHOWN ON THE DRAWING ARE TO BE INSTALLED IN STRICT ACCORDANCE WITH MANUFACTURER'S/ SUPPLIERS' RECOMMENDATIONS.

ANY INFORMATION RELATING TO THE DRAWING AND ANY OTHER CONTRACT INFORMATION ON MANUFACTURER'S/ SUPPLIERS' RECOMMENDATIONS IS TO BE BROUGHT TO THE ATTENTION OF THE ARCHITECT.

ALL DRAWINGS ARE NOT FOR CONSTRUCTION UNLESS SPECIFICALLY MARKED FOR THE PURPOSE. DO NOT SCALE FROM THE DRAWING. QUERIES TO BE DIRECTED TO THE ARCHITECT.

Replacement Door  
Refer to sheet 301

1

4 New Glazing to  
existing window  
Refer to sheet 304

5 New Glazing to  
existing window  
Refer to sheet 305

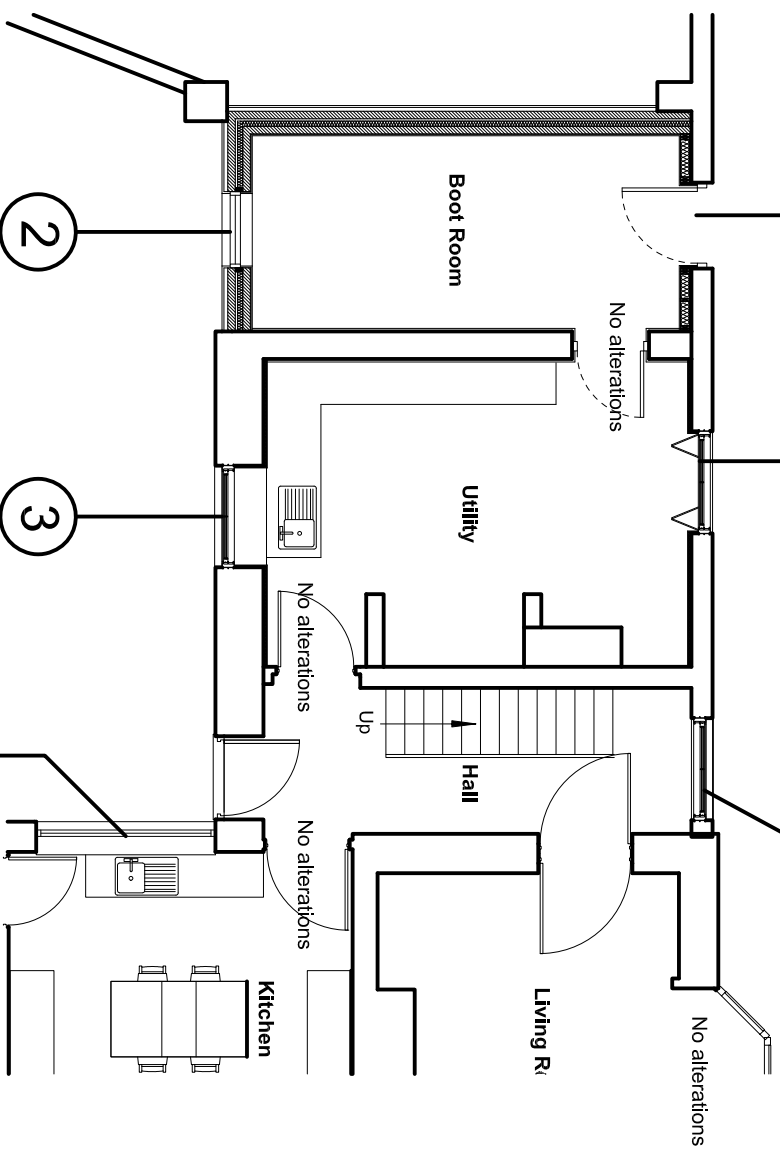

New Window  
Refer to sheet 302

New Glazing to  
existing window  
Refer to sheet 303

8 Replacement window  
Refer to sheets 308, 309

## Ground Floor

New Glazing to  
existing window  
Refer to sheet 307

7

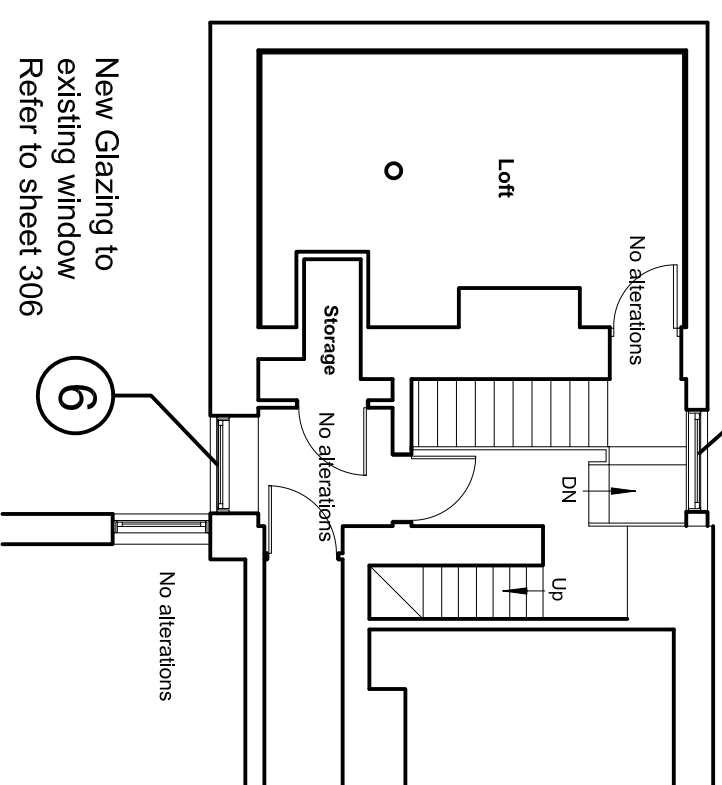

New Glazing to  
existing window  
Refer to sheet 306

6

## First Floor

Revised to client comments

A HB 18.03.24

DESCRIPTION: REV: BY: DATE:

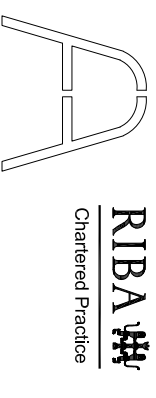

**form:form**  
architects

SUITE 0 FIRST FLOOR  
11, FLEET STREET  
SHREWSBURY, SHROPSHIRE, SY17 2BZ  
T: 01743 831743  
F: 01743 831743  
W: formformarchitects.com

CLIENT: Mr and Mrs Pizzo

PROJECT: Alterations to The Old  
Rectory, Llanysall

TITLE: Window / Door alterations plan

DRAWING NO: 300 REV: / JOB NO: 240104

SCALE: 1:50 @ A3 STATUS: DOC

DATE: 18/03/24 DRAWN: HB

1135

985

Timber hardwood -  
Painted White RAL 9010  
to match existing

A-A

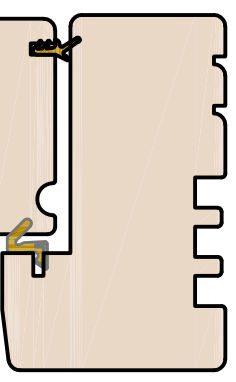
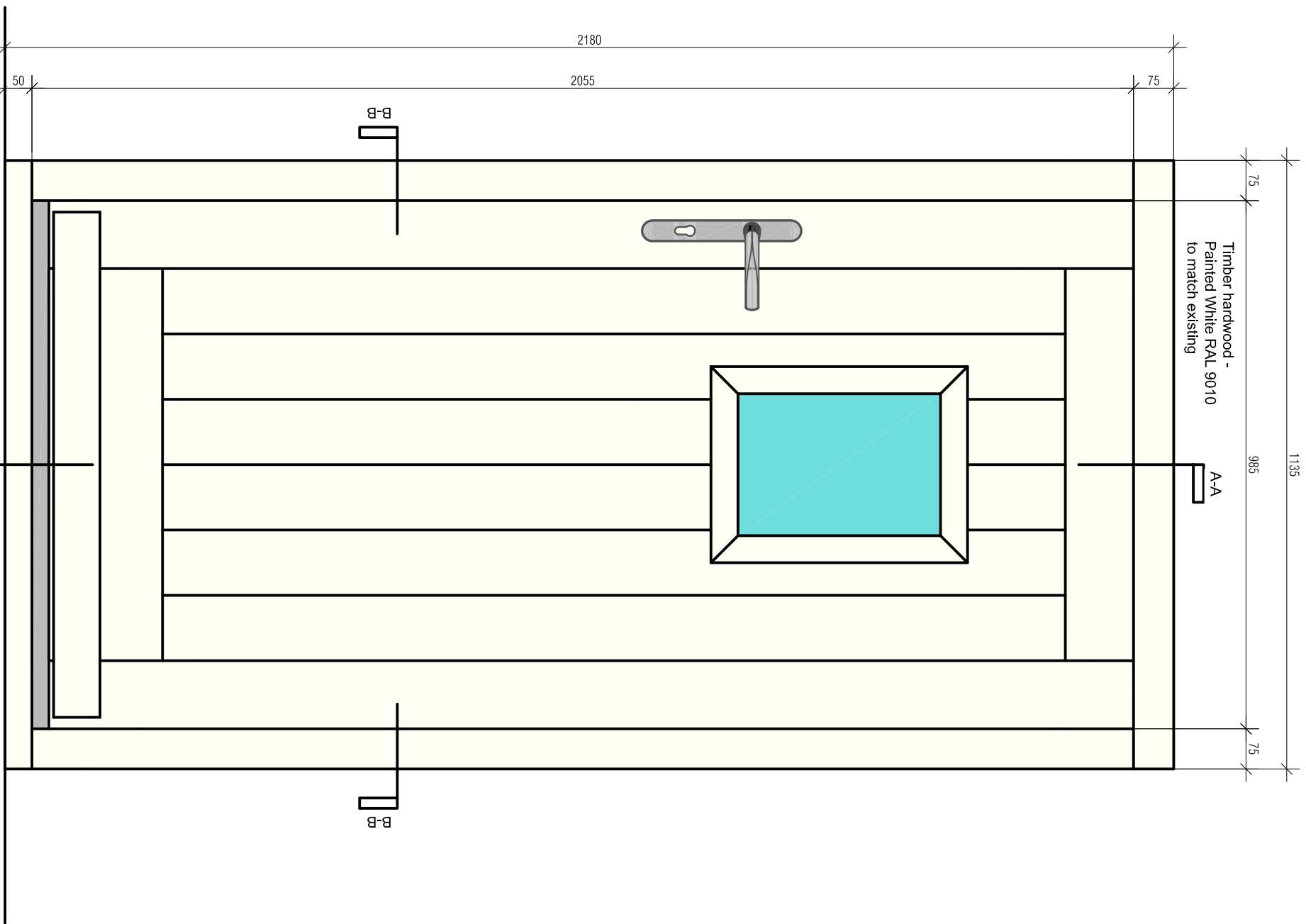

Section A-A  
Door Head

Scale 1:2

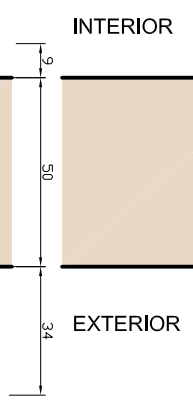

Section A-A  
Door Sill

Scale 1:2

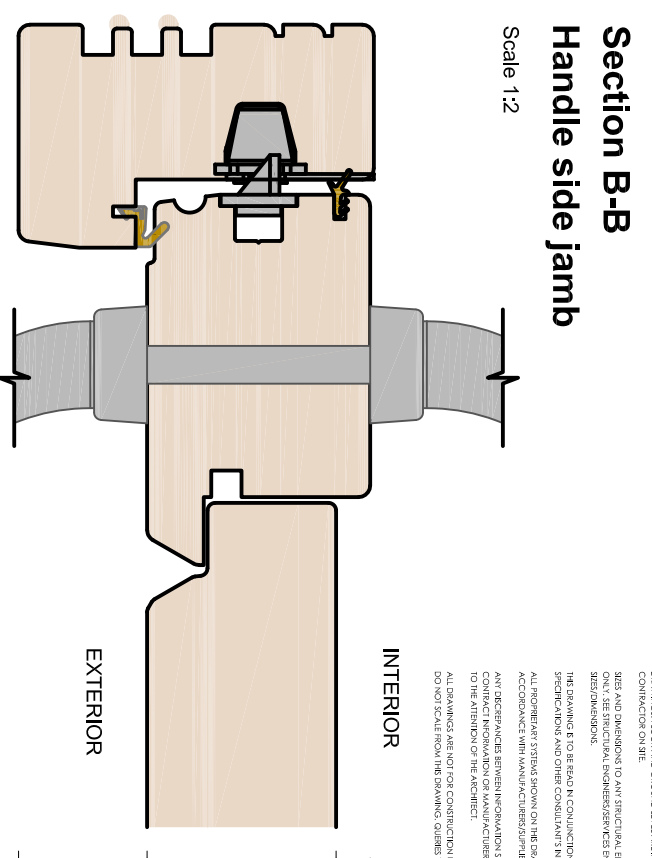

Section B-B  
Handle side jamb

Scale 1:2

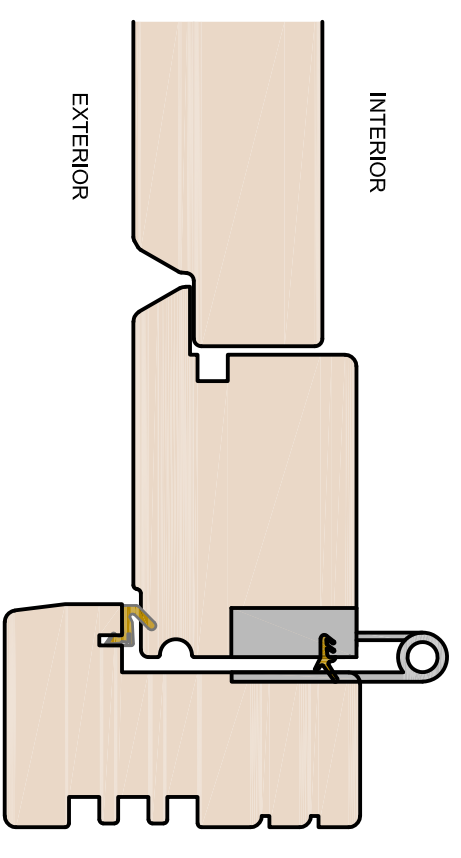

Section B-B  
Hinge side jamb

Scale 1:2

**GENERAL NOTES:**  
THIS DRAWING IS THE PROPERTY OF THE ARCHITECT AND IS TO BE USED ONLY FOR THE PROJECT AND SITE SPECIFICALLY MENTIONED THEREIN. IT IS NOT TO BE REPRODUCED, COPIED, OR TRANSMITTED IN ANY FORM OR BY ANY MEANS, ELECTRONIC OR MECHANICAL, INCLUDING PHOTOCOPYING, RECORDING, OR BY ANY INFORMATION STORAGE AND RETRIEVAL SYSTEM, WITHOUT THE WRITTEN PERMISSION OF THE ARCHITECT.  
ALL MATERIALS AND COMPONENTS MUST BE SUITABLE FOR THEIR INTENDED PURPOSE AND LOCATION AND MUST BE MANUFACTURED AND FINISHED IN ACCORDANCE WITH ALL RELEVANT LOCAL, NATIONAL, AND INTERNATIONAL STANDARDS AND REGULATIONS. THE ARCHITECT'S SPECIFICATIONS SHALL TAKE PRECEDENCE OVER ANY OTHER SPECIFICATIONS.  
ALL DIMENSIONS ARE TO FACE UNLESS SPECIFICALLY MARKED FOR THE PURPOSE. DIMENSIONS FOR AND OPENING LEVELS ARE INDICATED ON THE DRAWING.  
THIS DRAWING IS TO BE READ IN CONJUNCTION WITH ALL OTHER ARCHITECT DRAWINGS, SPECIFICATIONS AND OTHER CONSULTANT'S INFORMATION.  
ALL PROPOSED SYSTEMS SHOWN ON THE DRAWING ARE TO BE INSTALLED IN STRICT ACCORDANCE WITH MANUFACTURER'S RECOMMENDATIONS.  
ANY REQUIREMENTS, NOTES, OR INFORMATION ON THE DRAWING AND ANY OTHER CONTRACT INFORMATION OR MANUFACTURER'S RECOMMENDATIONS TO BE BROUGHT TO THE ATTENTION OF THE ARCHITECT.  
ALL DRAWINGS ARE NOT FOR CONSTRUCTION UNLESS SPECIFICALLY MARKED FOR THE PURPOSE. DO NOT SCALE FROM THE DRAWING. QUERIES TO BE DIRECTED TO THE ARCHITECT.

Revised to client comments A HB 18.03.24

REV: DESCRIPTION: BY: DATE:

**form:form architects**

SUITE 0 FIRM FLOOR  
11, THE FIRM BUILDING  
STREETSURF, STROUD, SYDNEY  
T: +61 (0)1743 631280  
F: +61 (0)1743 631280  
W: formformarchitects.com

**RIBA** Chartered Practice

CLIENT: Mr and Mrs Pizzo

PROJECT: Alterations to The Old Rectory, Lambysall

TITLE: Replacement Door - Bedroom

DRAWING NO:	REV:	JOB NO:
301	/	240104
SCALE:	STATUS:	DOC
As detailed	DOC	
DATE: Mar'24	DRAWN: HB	

1

**GENERAL NOTES:**

ALL WORK SHOWN IS TO BE CONSIDERED BY A FULL BUILDING REGULATORY APPLICATION AND THEREFORE ALL WORK SHOWN MUST COMPLY WITH THE CURRENT BUILDING REGULATORY APPROVED DOCUMENTS AND TO THE SATISFACTION OF THE LOCAL AUTHORITY BUILDING CONTROL OFFICER UNLESS A THIRD PARTY REGULATION IS REFERRED TO IN THE CURS.

ALL MATERIALS AND COMPONENTS MUST BE SUITABLE FOR THEIR INTENDED PURPOSE AND LOCATION AND MUST BE MANUFACTURED AND INSTALLED IN ACCORDANCE WITH ALL RELEVANT MANUFACTURER'S SPECIFICATIONS AND CODES OF PRACTICE (WHEN REFERRED TO) AND MANUFACTURER'S SPECIFICATION.

ALL DRAWINGS ARE TO BE CHECKED ON THE PROJECT COMMENCEMENT OF ANY WORK ON ANY DRAWINGS, FLOOR AND CROSSLING LEVELS, AND INDICATED ON IT AND TO BE COMBINED BY CONSTRUCTION ON SITE.

DESIGN AND CONSTRUCTION TO ANY STRUCTURAL ELEMENTS AND SERVICE ELEMENTS ARE INDICATED ONLY. SEE STRUCTURAL ENGINEER'S SERVICES ENGINEER DRAWINGS FOR ACTUAL DESIGN DIMENSIONS.

THIS DRAWING IS TO BE READ IN CONJUNCTION WITH ALL OTHER ARCHITECT'S DRAWINGS, SPECIFICATIONS AND OTHER CONSULTANT'S INFORMATION.

ALL PROPOSED SYSTEMS SHOWN ON THE DRAWING ARE TO BE INSTALLED IN STRICT ACCORDANCE WITH MANUFACTURER'S/ SUPPLIERS' RECOMMENDED DETAILS.

ANY RELEVANT REGULATORY INFORMATION ON THE DRAWING AND ANY OTHER CONTRACT INFORMATION ON MANUFACTURER'S/ SUPPLIERS' RECOMMENDATIONS IS TO BE BROUGHT TO THE ATTENTION OF THE ARCHITECT.

ALL DRAWINGS ARE NOT FOR CONSTRUCTION UNLESS SPECIFICALLY MARKED FOR THE PURPOSE. DO NOT SCALE FROM THE DRAWING. QUERIES TO BE DIRECTED TO THE ARCHITECT.

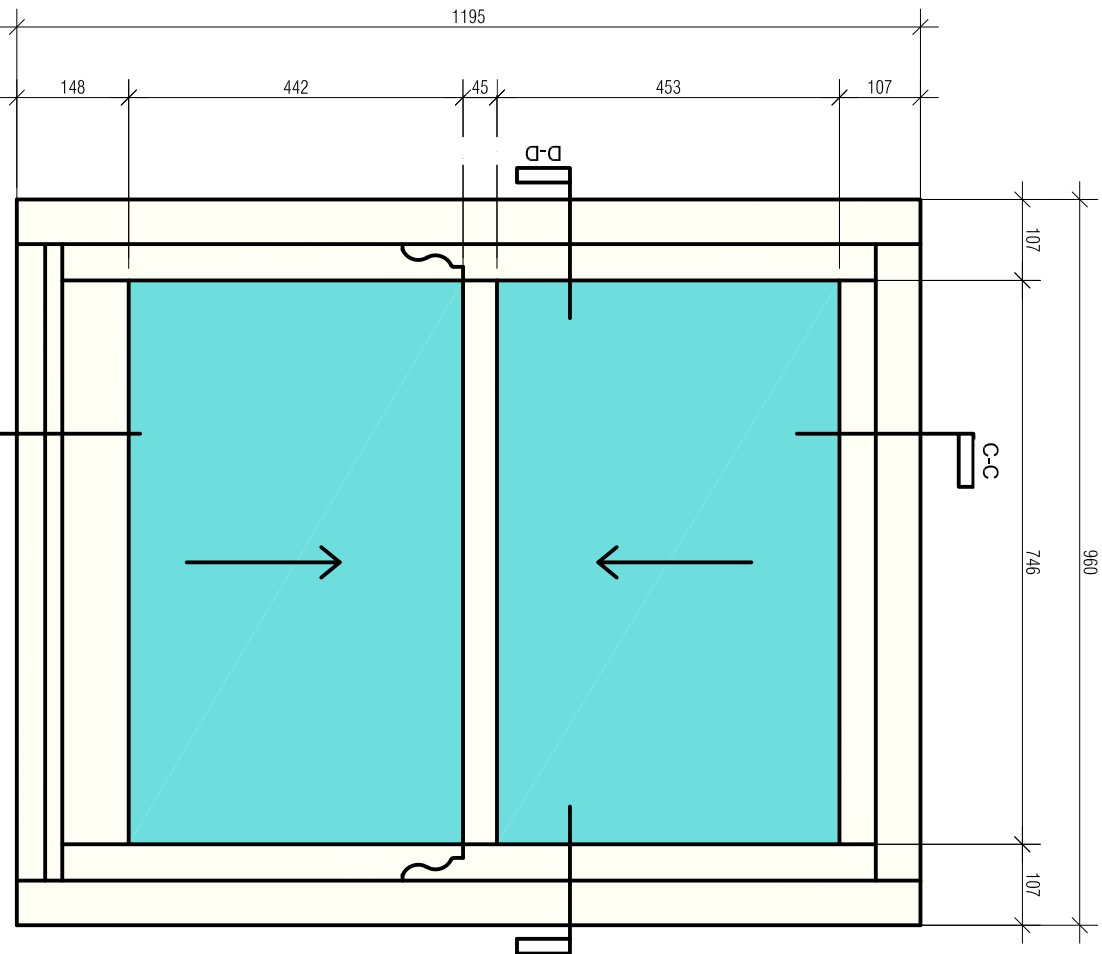

**Elevation**  
Scale 1:10

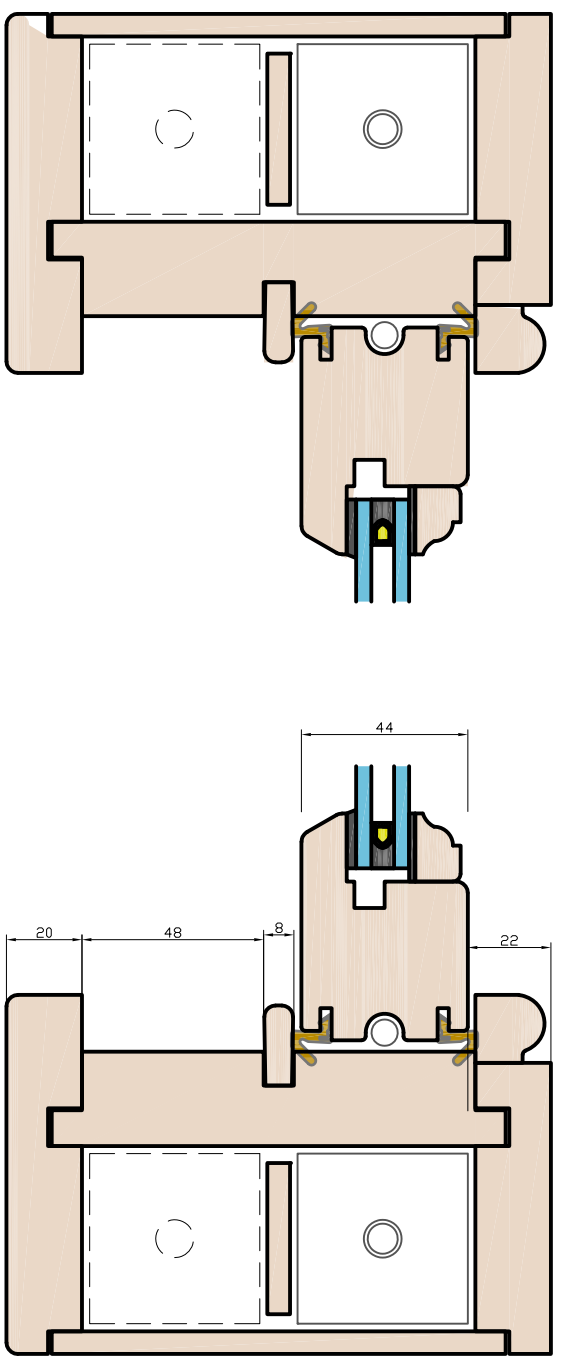

**Section D-D**  
Scale 1:2

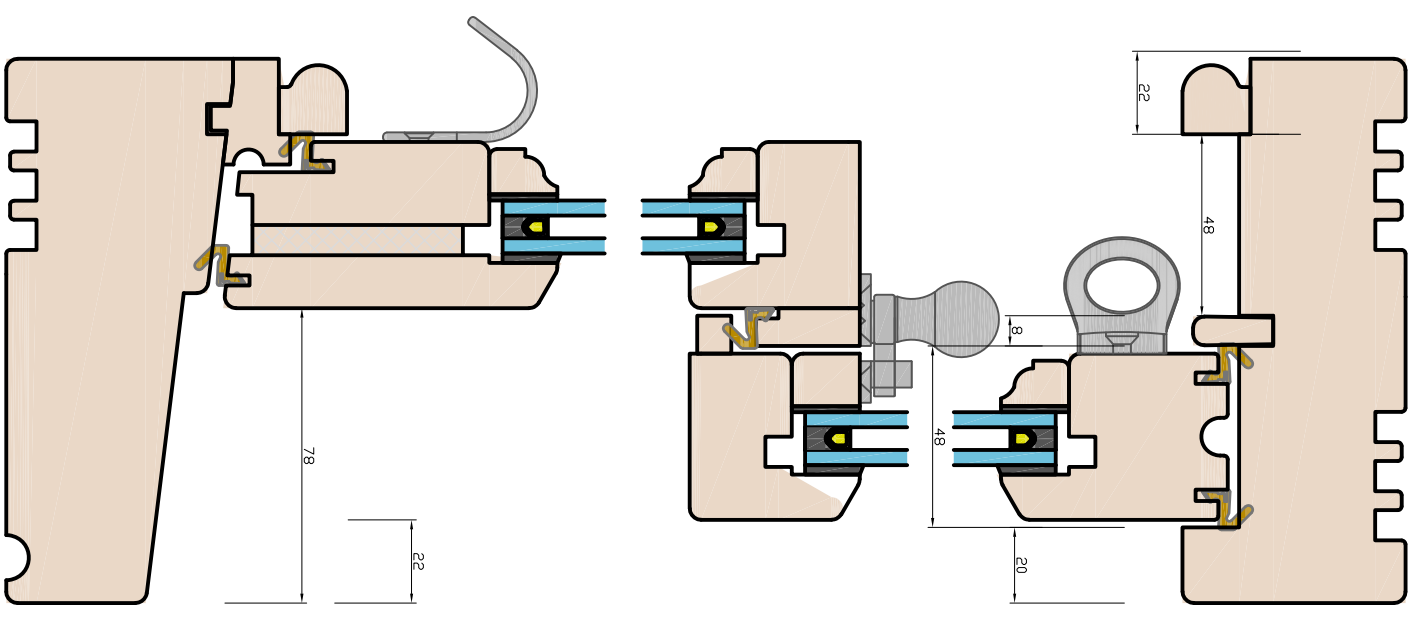

**Section C-C**  
Scale 1:2

2

Revised to client comments A HB 18.03.24  
REV: DESCRIPTION: BY: DATE:



**form:form architects**  
S U I T E 0 F F I R M F I N A N C I A L  
S T R U C T U R A L E N G I N E E R I N G  
S H E W B U R Y, S H R O P S H I R E, S Y 1 2 8 Z  
T : + 4 4 ( 0 ) 1 7 5 3 6 1 1 2 8 0  
E : i n f o @ f o r m f i n a n c i a l . c o m  
W : f o r m f o r m a r c h i t e c t s . c o m

CLIENT: Mr and Mrs Pizzo  
PROJECT: Alterations to The Old Rectory, Lambysall

TITLE: New Window - Bootroom  
DRAWING NO: 302  
JOB NO: 240104  
REV: /  
SCALE: As indicated  
STATUS: DOC  
DATE: Mar'24  
DRAWN: HB

**GENERAL NOTES:**

THIS DRAWING IS TO BE CONSIDERED BY A FULL BUILDING REGULATORY AUTHORITY AND THEREFORE ALL WORK SHOWN MUST COMPLY WITH THE CURRENT BUILDING REGULATORY AUTHORITY DOCUMENT AND TO THE SATISFACTION OF THE LOCAL AUTHORITY BUILDING CONTROL OFFICER UNLESS A DIFFERENT REQUIREMENT IS SPECIFIED BY THE CLIENT.  
 ALL MATERIALS AND COMPONENTS MUST BE SUITABLE FOR THEIR INTENDED PURPOSE AND LOCATION AND MUST BE MANUFACTURED AND INSTALLED IN ACCORDANCE WITH ALL RELEVANT STANDARDS AND REGULATIONS AND BE SUBJECT TO THE REVISIONS AND MANUFACTURER'S SPECIFICATION.  
 ALL DRAWINGS TO BE CHECKED ON THE PROJECT COMMENCEMENT OF ANY WORK ON THE DRAWINGS, FLOOR AND CROSSLING LEVELS, AND INDICATED ON THE DRAWING TO BE COMPLETED BY CONTRACTOR ON SITE.  
 THE DRAWING IS TO BE READ IN CONJUNCTION WITH ALL OTHER ARCHITECT'S DRAWINGS, SPECIFICATIONS AND OTHER CONSULTANT'S INFORMATION.  
 ALL PROPERTIES SHOWN ON THE DRAWING ARE TO BE INSTALLED IN ACCORDANCE WITH ALL RELEVANT STANDARDS AND REGULATIONS AND BE SUBJECT TO THE REVISIONS AND MANUFACTURER'S SPECIFICATION.  
 ANY INFORMATION SHOWN ON THE DRAWING IS FOR INFORMATION ONLY AND IS NOT TO BE USED FOR CONTRACT INFORMATION OR MANUFACTURER'S RECOMMENDATIONS OR TO BE RELIANT TO THE ATTENTION OF THE ARCHITECT.  
 ALL DRAWINGS ARE NOT FOR CONSTRUCTION UNLESS SPECIFICALLY MARKED FOR THE PURPOSE. DO NOT SCALE FROM THE DRAWING. QUERIES TO BE DIRECTED TO THE ARCHITECT.

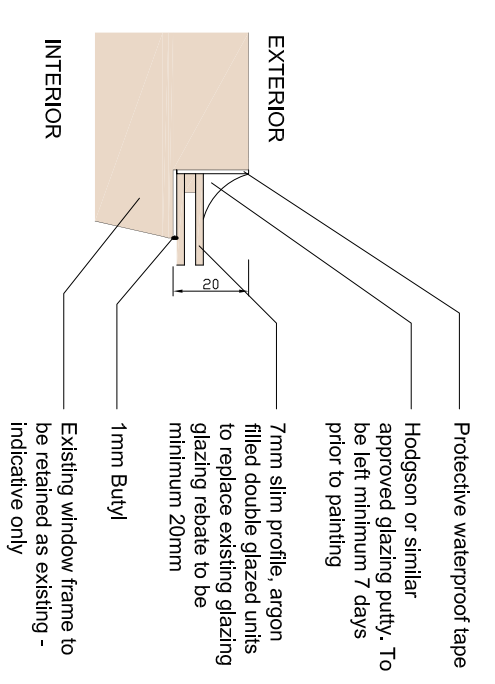
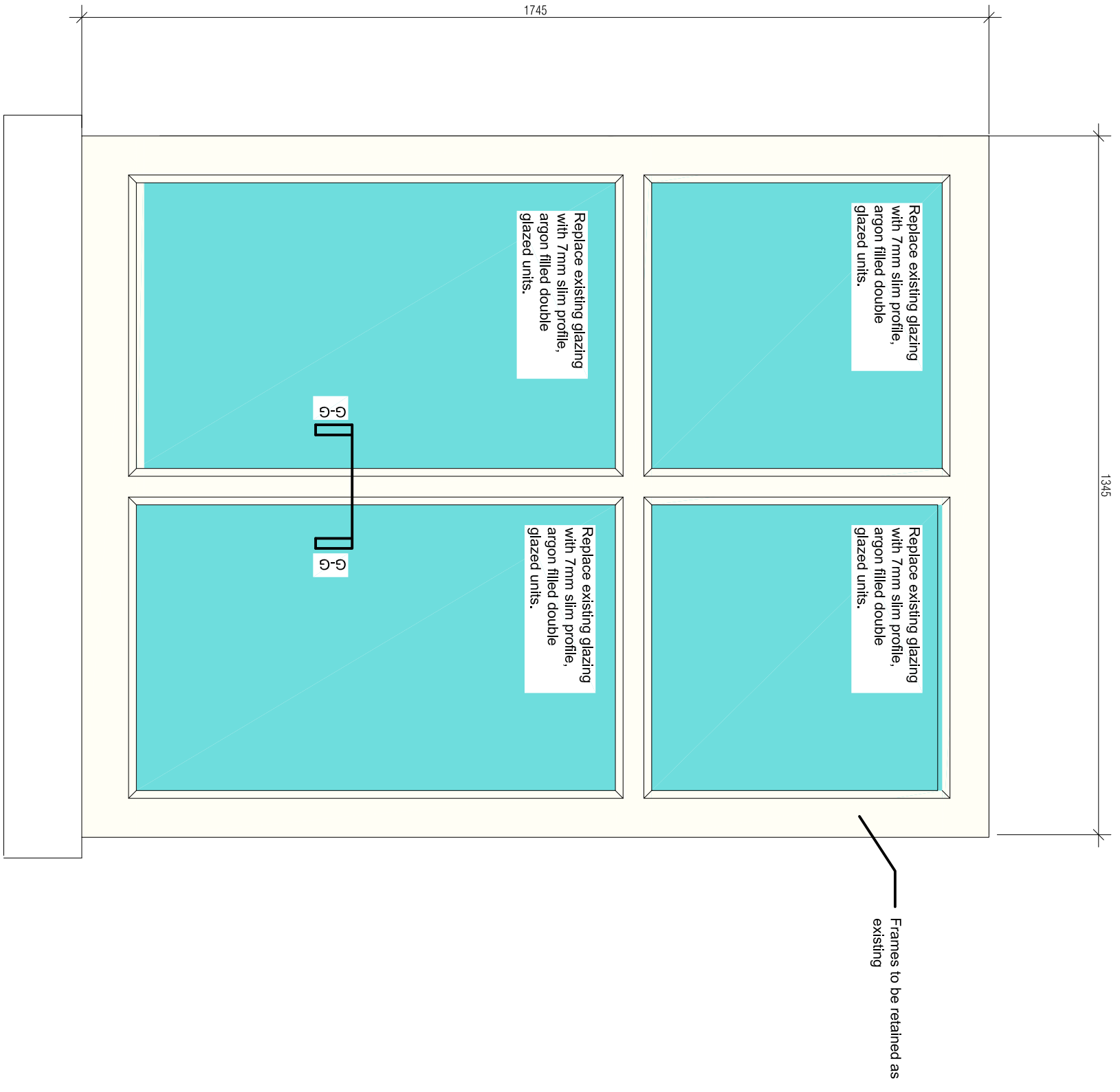

**Section G-G**  
**Replacement glazing detail**  
 Scale 1:2

Revised to client comments A HB 18.03.24

REV: DESCRIPTION: BY: DATE:

**form:form architects**

S U I T E 0 F F I R M F I N A N C I A L  
 S H E R B U R Y, S H R O U B H E, S Y 1 2 8 Z  
 T : 0 1 7 5 3 6 1 2 8 0  
 F : 0 1 7 5 3 6 1 2 8 0  
 W : f o r m f o r m a r c h i t e c t s . c o m

**RIBA** Chartered Practice

CLIENT: Mr and Mrs Pizzo

PROJECT: Alterations to The Old Rectory, Llandysall

TITLE: New Glazing to existing window 3

DRAWING NO:	REV:	JOB NO:
303	/	240104
SCALE:	STATUS:	DOC
As indicated	DOC	
DATE: Mar '24	DRAWN: HB	

3

**GENERAL NOTES:**  
 THIS DRAWING IS TO BE USED IN CONJUNCTION WITH ALL OTHER ARCHITECT'S DRAWINGS, SPECIFICATIONS AND OTHER CONSULTANT'S INFORMATION.  
 ALL PROPERTIES SHOWN ON THIS DRAWING ARE TO BE INCLUDED IN THE CONTRACT INFORMATION ON MANUFACTURERS' SPECIFICATIONS RECOMMENDED BY THE ARCHITECT.  
 ANY INFORMATION ON MANUFACTURERS' SPECIFICATIONS RECOMMENDED BY THE ARCHITECT IS NOT TO BE USED FOR CONSTRUCTION UNLESS SPECIFICALLY MARKED FOR THE PURPOSE. DO NOT SCALE FROM THIS DRAWING. QUERIES TO BE DIRECTED TO THE ARCHITECT.  
 ALL DRAWINGS TO BE CHECKED ON THE SITE AND APPROVED BY THE ARCHITECT BEFORE COMMENCEMENT OF ANY WORK. ON-SITE DRAWINGS, FLOOR AND SECTION LEVELS, AND DIMENSIONS TO BE CHECKED BY THE ARCHITECT AND REPORTED TO THE ARCHITECT.  
 THIS DRAWING IS TO BE USED IN CONJUNCTION WITH ALL OTHER ARCHITECT'S DRAWINGS, SPECIFICATIONS AND OTHER CONSULTANT'S INFORMATION.  
 ALL PROPERTIES SHOWN ON THIS DRAWING ARE TO BE INCLUDED IN THE CONTRACT INFORMATION ON MANUFACTURERS' SPECIFICATIONS RECOMMENDED BY THE ARCHITECT.  
 ANY INFORMATION ON MANUFACTURERS' SPECIFICATIONS RECOMMENDED BY THE ARCHITECT IS NOT TO BE USED FOR CONSTRUCTION UNLESS SPECIFICALLY MARKED FOR THE PURPOSE. DO NOT SCALE FROM THIS DRAWING. QUERIES TO BE DIRECTED TO THE ARCHITECT.

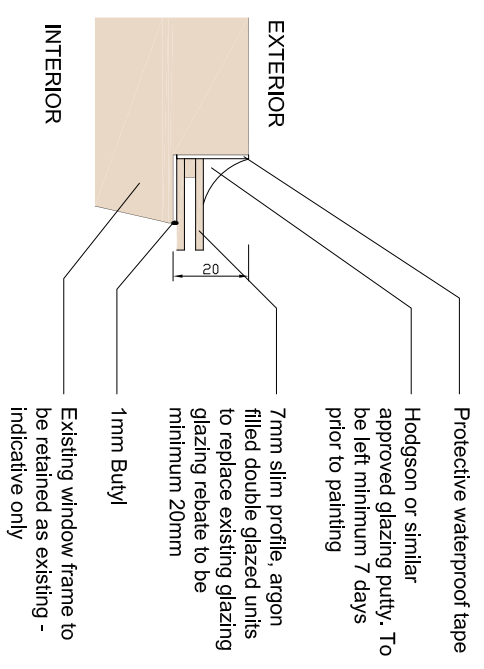
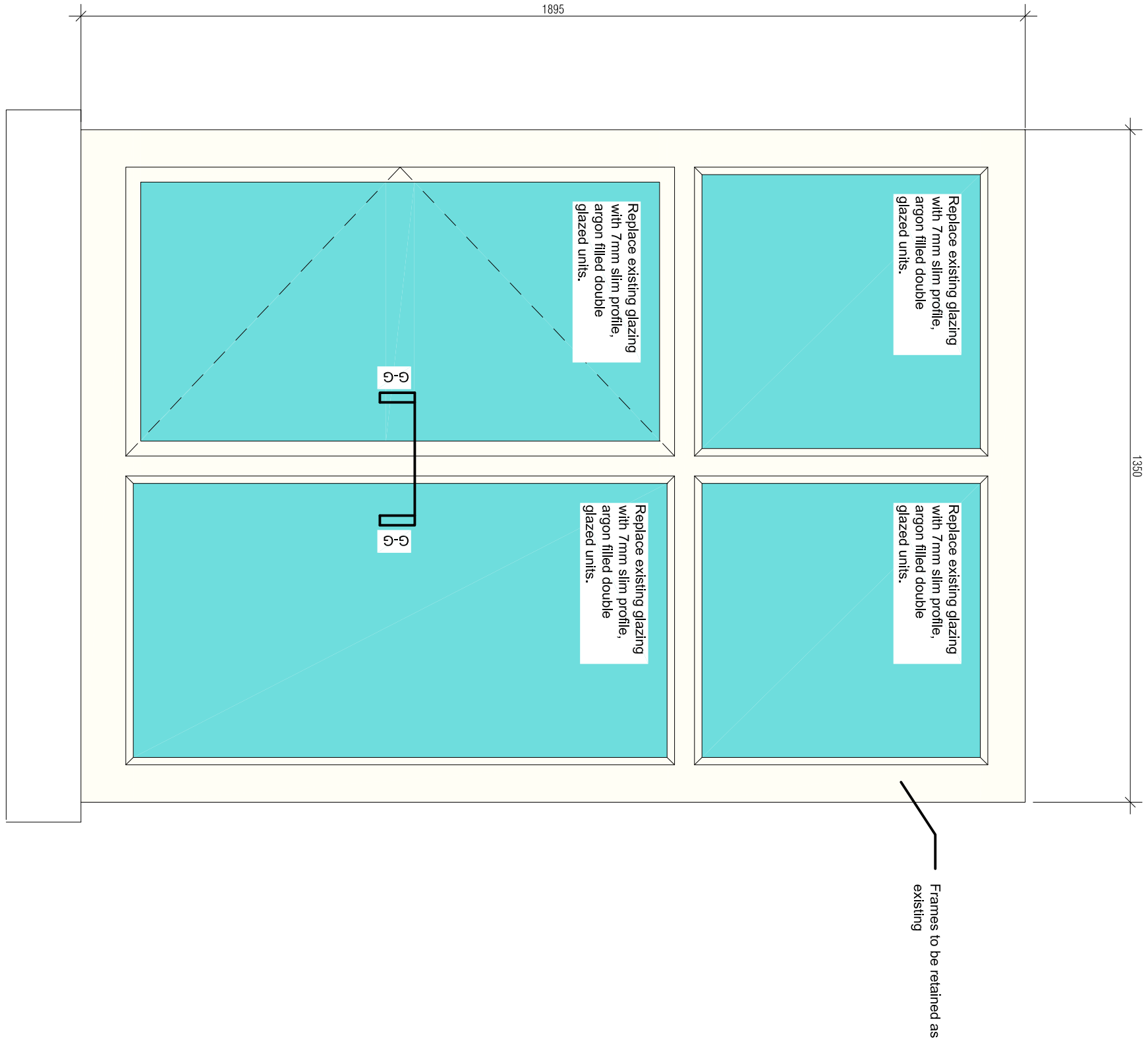

**Section G-G**  
**Replacement glazing detail**  
 Scale 1:2

4

Revised to client comments

REV: DESCRIPTION:	A	HB	18.03.24
BY:	DATE:		

**RIBA**  
 Chartered Practice

**form:form architects**  
 SUITE 0 FIRM FLOOR  
 100 WOODS ROAD  
 SHREWSBURY, SHROPSHIRE, SY17 2SE  
 T: 01743 821280  
 F: 01743 821281  
 W: formformarchitects.com

CLIENT: Mr and Mrs Pizzo  
 PROJECT: Alterations to The Old Rectory, Llanoyvall

TITLE:	New Glazing to existing window 4		
DRAWING NO:	REV:	JOB NO:	
304	/	240104	
SCALE:	STATUS:	DOC	
As Issued	DOC		
DATE: Mar '24	DRAWN: HB		

**GENERAL NOTES:**

THESE DRAWINGS HAVE BEEN PREPARED BY A FULL TIME REGULARLY EMPLOYED ARCHITECT AND SHOULD BE USED IN ACCORDANCE WITH THE CURRENT BUILDING REGULATIONS AND ALL WORK SHOWN SHOULD COMPLY WITH THE CURRENT BUILDING REGULATIONS AND TO THE SATISFACTION OF THE LOCAL AUTHORITY BUILDING CONTROL OFFICER UNLESS A FURTHER REVISION IS NOTED IN THE CURR. ALL MATERIALS AND COMPONENTS MUST BE SUITABLE FOR THEIR INTENDED PURPOSE AND LOCATION AND MUST BE MANUFACTURED AND INSTALLED IN ACCORDANCE WITH ALL RELEVANT MANUFACTURER'S SPECIFICATIONS AND CODES OF PRACTICE. REVISIONS AND MANUFACTURER'S SPECIFICATIONS.

ALL DRAWINGS TO BE CHECKED ON THE SITE FOR ACCURACY OF ANY WORK SHOWN. DRAWINGS, FLOOR AND SECTION LEVELS, DIMENSIONS AND TO BE CORRECTED BY CONTRACTOR ON SITE.

REVISIONS TO BE MADE TO ANY STRUCTURAL, PLUMBING AND SERVICES DRAWINGS MUST BE MADE TO THE ORIGINAL DRAWINGS AND NOT TO ANY COPY.

THE DRAWING IS TO BE READ IN CONJUNCTION WITH ALL OTHER ARCHITECT'S DRAWINGS, SPECIFICATIONS AND OTHER CONSULTANT'S INFORMATION.

ALL PROPOSED WORK SHOWN ON THE DRAWING ARE TO BE INSTALLED IN ACCORDANCE WITH ALL RELEVANT MANUFACTURER'S SPECIFICATIONS AND CODES OF PRACTICE. REVISIONS AND MANUFACTURER'S SPECIFICATIONS.

ANY INFORMATION ON THE DRAWING IS TO BE INSTALLED IN ACCORDANCE WITH ALL RELEVANT MANUFACTURER'S SPECIFICATIONS AND CODES OF PRACTICE. REVISIONS AND MANUFACTURER'S SPECIFICATIONS.

ALL DRAWINGS ARE NOT FOR CONSTRUCTION UNLESS SPECIFICALLY MARKED FOR THE PURPOSE. DO NOT SCALE FROM THE DRAWING. DIMENSIONS TO BE DIRECTED TO THE ARCHITECT.

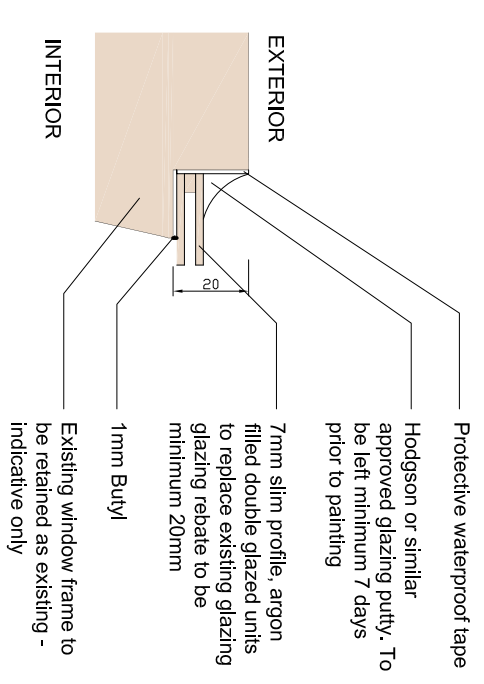
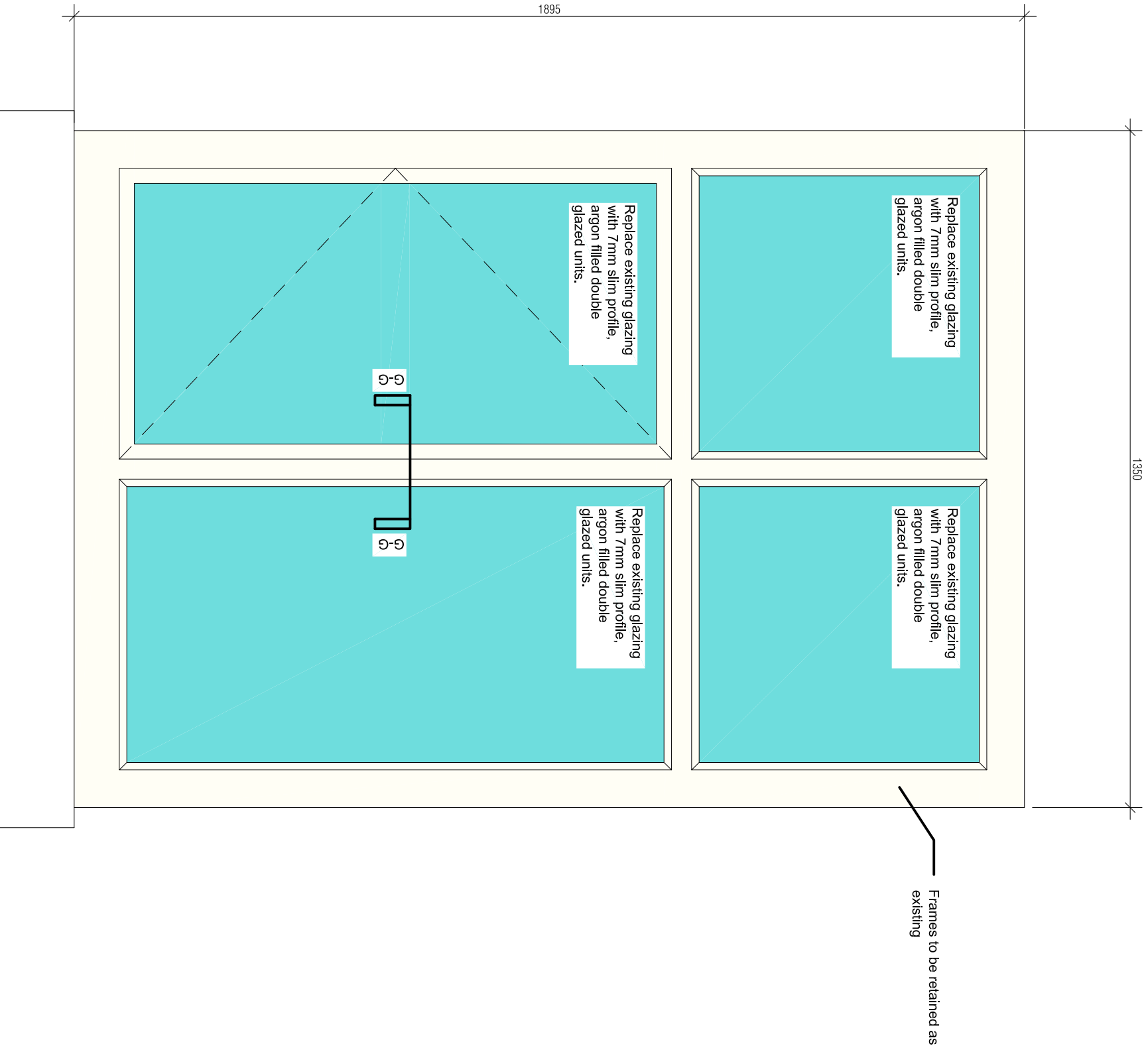

**Section G-G  
Replacement glazing detail**

Scale 1:2

Revised to client comments A HB 18.03.24

REV: DESCRIPTION: BY: DATE:

**form:form architects**

S U I T E 0 1 F I R M F L O O R  
100, High Street, 1st Floor  
Shrewsbury, Shropshire, SY1 2BZ  
t : +44 (0)1743 631280  
f : +44 (0)1743 631281  
w : formformarchitects.com

**RIBA** Chartered Practice

CLIENT: Mr and Mrs Pizzo  
PROJECT: Alterations to The Old Rectory, Llanvysall

TITLE: New Glazing to existing window 5

DRAWING NO:	REV:	JOB NO:
305	/	240104
SCALE:	STATUS:	DOC
As indicated	DOC	
DATE: Mar '24	DRAWN: HB	

5

**GENERAL NOTES:**

THIS DRAWING IS TO BE CONSIDERED AS A FULL BUILDING REGULATION APPLICATION AND THEREFORE ALL WORK SHOWN MUST COMPLY WITH THE CURRENT BUILDING REGULATIONS APPLICABLE TO THE PROJECT AND TO THE SATISFACTION OF THE LOCAL AUTHORITY BUILDING CONTROL OFFICER UNLESS A DIFFERENT REQUIREMENT IS SPECIFIED IN THE CONTRACT. ALL MATERIALS AND COMPONENTS MUST BE SUITABLE FOR THEIR INTENDED PURPOSE AND LOCATION AND MUST BE MANUFACTURED AND INSTALLED IN ACCORDANCE WITH ALL RELEVANT BUILDING REGULATIONS AND THE CODES OF PRACTICE, WITH RESPECT TO THE RELEVANT MANUFACTURER'S SPECIFICATION. ALL DRAWINGS TO BE CHECKED ON THE PROJECT COMMENCEMENT OF ANY WORK ON THIS DRAWING. FLOOR AND CEILING LEVELS, WHERE APPLICABLE, MUST BE INDICATED ON ALL DRAWINGS AND CHECKED ON SITE. THE DRAWING IS TO BE READ IN CONJUNCTION WITH ALL OTHER ARCHITECT'S DRAWINGS, SPECIFICATIONS AND OTHER CONSULTANT'S INFORMATION. ALL PROPERTIES SHOWN ON THE DRAWING ARE TO BE REGULARLY MAINTAINED IN ACCORDANCE WITH MANUFACTURER'S RECOMMENDATIONS. ANY INFORMATION ON MANUFACTURER'S RECOMMENDATIONS IS TO BE OBTAINED FROM THE MANUFACTURER'S SPECIFICATION. ALL DRAWINGS ARE NOT FOR CONSTRUCTION UNLESS SPECIFICALLY MARKED FOR THE PURPOSE. DO NOT SCALE FROM THE DRAWING. QUERIES TO BE DIRECTED TO THE ARCHITECT.

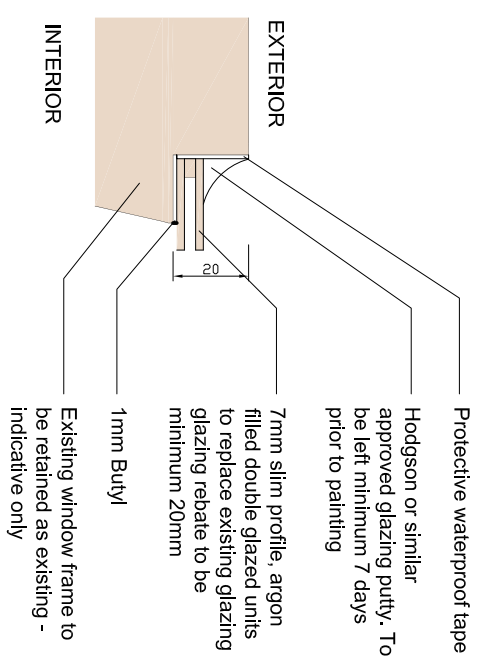
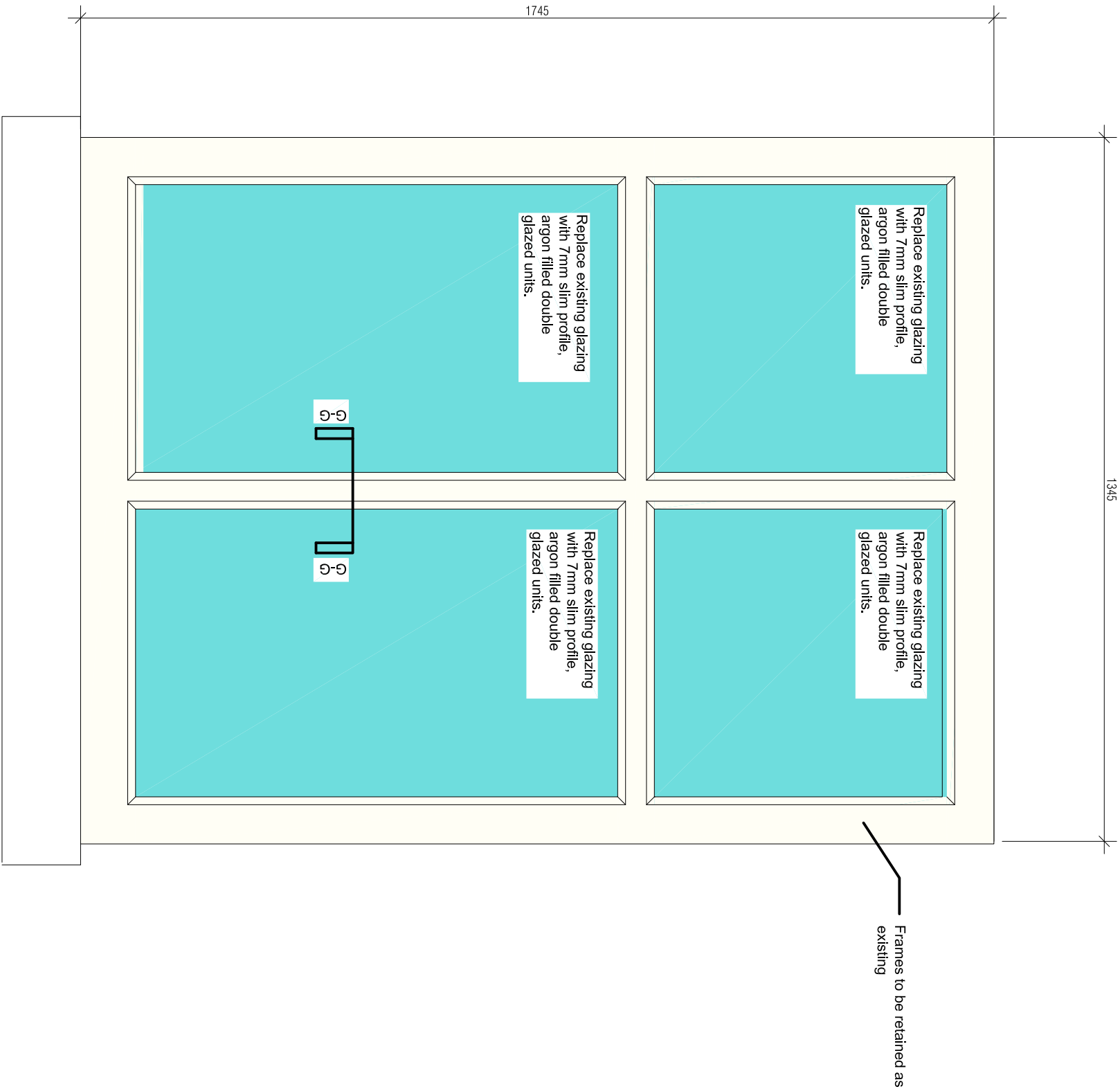

**Section G-G**  
**Replacement glazing detail**  
 Scale 1:2

6

Revised to client comments A HB 18.03.24  
 REV: DESCRIPTION: BY: DATE:

**form:form architects**  
 SUITE 6 FIRST FLOOR  
 100-102, STATION SQUARE  
 STREETSURF, STROPSHIRE, SY1 2BZ  
 T: 01469 431743  
 F: 01469 431744  
 W: www.formformarchitects.com

**RIBA**  
 Chartered Practice

CLIENT: Mr and Mrs Pizzo  
 PROJECT: Alterations to The Old Rectory, Llanrysgall

TITLE: New Glazing to existing window 6

DRAWING NO:	REV:	JOB NO:
306	/	240104
SCALE:	STATUS:	DOC
As indicated	DOC	
DATE: Mar '24	DRAWN: HB	

**GENERAL NOTES:**

THESE DRAWINGS HAVE BEEN PREPARED BY A FULL TIME REGISTERED ARCHITECT AND THEREFORE ALL WORK SHOWN MUST COMPLY WITH THE CURRENT BUILDING REGULATIONS APPLICABLE TO THE PROJECT AND TO THE JURISDICTION OF THE LOCAL AUTHORITY BUILDING CONTROL OFFICE UNLESS A FURTHER REVISION IS SPECIFICALLY NOTED BY THE CLIENT.  
 ALL MATERIALS AND COMPONENTS MUST BE SUITABLE FOR THEIR INTENDED PURPOSE AND LOCATION AND MUST BE MANUFACTURED AND INSTALLED IN ACCORDANCE WITH ALL RELEVANT BUILDING REGULATIONS AND CODES OF PRACTICE. THIS REQUIREMENT INCLUDES RELEVANT MANUFACTURER SPECIFICATIONS.  
 ALL DRAWINGS TO BE CHECKED ON THE PROJECT COMMENCEMENT OF ANY WORK ON THIS PROJECT. FLOOR AND CEILING LEVELS, APPLICABLE TO ALL DRAWINGS, MUST BE INDICATED ON ALL DRAWINGS AND CHECKED ON SITE.  
 THIS DRAWING IS TO BE READ IN CONJUNCTION WITH ALL OTHER ARCHITECT'S DRAWINGS, SPECIFICATIONS AND OTHER CONSULTANT'S INFORMATION.  
 ALL PROPOSED STAFFS SHOWN ON THE DRAWING ARE TO BE INSTALLED IN ACCORDANCE WITH ALL RELEVANT BUILDING REGULATIONS AND CODES OF PRACTICE. THIS REQUIREMENT INCLUDES RELEVANT MANUFACTURER SPECIFICATIONS.  
 ANY PERFORMANCE SPECIFICATIONS OR INFORMATION ON THE DRAWING AND ANY OTHER CONTRACT INFORMATION OR MANUFACTURER'S RECOMMENDATIONS IS TO BE BROUGHT TO THE ATTENTION OF THE ARCHITECT.  
 ALL DRAWINGS ARE NOT FOR CONSTRUCTION UNLESS SPECIFICALLY MARKED FOR THE PURPOSE. DO NOT SCALE FROM THE DRAWING. QUERIES TO BE DIRECTED TO THE ARCHITECT.

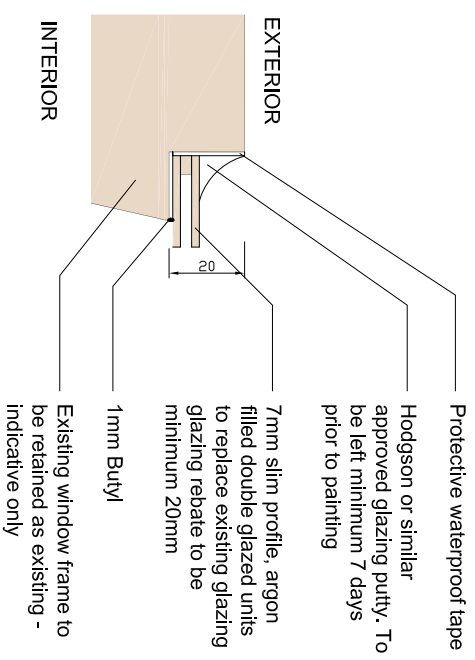
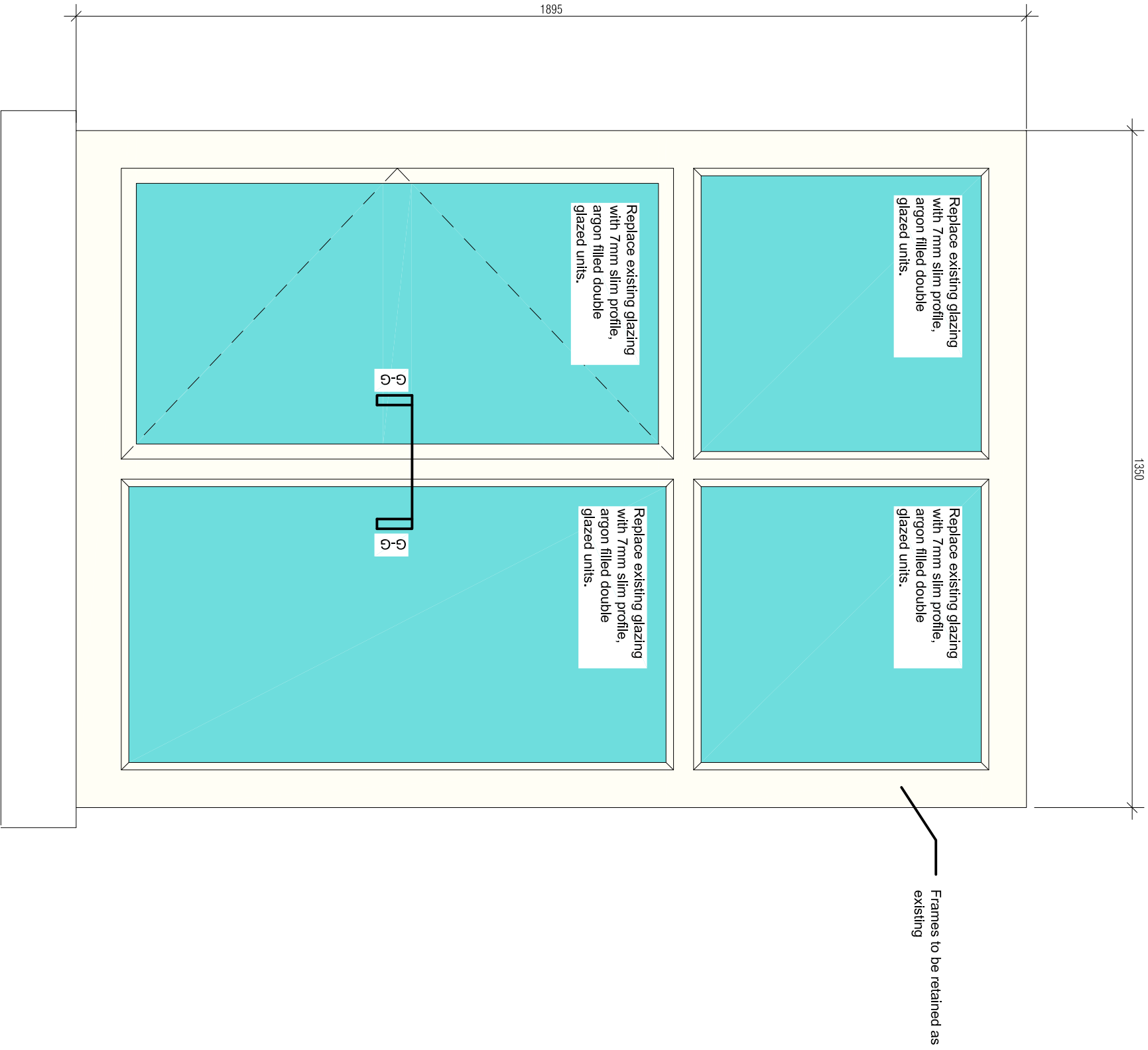

**Section G-G**  
**Replacement glazing detail**  
 Scale 1:2

7

**form:form architects**  
 SUITE 0 FIFTH FLOOR  
 100, MARKET STREET  
 SHEFFIELD, S11 2BQ  
 T: 0114 236 1280  
 F: 0114 236 1281  
 W: formformarchitects.com



**CLIENT:** Mr and Mrs Pizzo  
**PROJECT:** Alterations to The Old Rectory, Llandysall

<b>TITLE:</b> New Glazing to existing window 7	<b>REV:</b> /	<b>JOB NO:</b> 240104
<b>DRAWING NO:</b> 307	<b>STATUS:</b> As Issued	<b>DOC</b>
<b>DATE:</b> Mar '24	<b>DRAWN:</b> HB	

<b>REV:</b> Revised to client comments	<b>BY:</b> A	<b>DATE:</b> HB 18.03.24
----------------------------------------	--------------	--------------------------



**GENERAL NOTES:**

ALL DRAWINGS TO BE CHECKED ON SITE FOR COMPLIANCE WITH ALL OTHER ARCHITECT'S DRAWINGS, SPECIFICATIONS AND OTHER CONSULTANT'S INFORMATION.  
 ALL PROPOSED STAIRS SHOWN ON THE DRAWING ARE TO BE INSTALLED IN ACCORDANCE WITH MANUFACTURER'S SPECIFICATIONS RECOMMENDED BY THE ARCHITECT.  
 ANY REPAIRS AND ALTERATIONS TO EXISTING STRUCTURE AND SERVICES SHALL BE TO THE SATISFACTION OF THE ARCHITECT.  
 ALL DRAWINGS ARE NOT FOR CONSTRUCTION UNLESS SPECIFICALLY MARKED FOR THE PURPOSE. DO NOT SCALE FROM THE DRAWING. QUERIES TO BE DIRECTED TO THE ARCHITECT.

ALL DRAWINGS TO BE CHECKED ON SITE FOR COMPLIANCE WITH ALL OTHER ARCHITECT'S DRAWINGS, SPECIFICATIONS AND OTHER CONSULTANT'S INFORMATION.  
 ALL PROPOSED STAIRS SHOWN ON THE DRAWING ARE TO BE INSTALLED IN ACCORDANCE WITH MANUFACTURER'S SPECIFICATIONS RECOMMENDED BY THE ARCHITECT.  
 ANY REPAIRS AND ALTERATIONS TO EXISTING STRUCTURE AND SERVICES SHALL BE TO THE SATISFACTION OF THE ARCHITECT.

Timber hardwood -  
 Painted White RAL 9010  
 to match existing

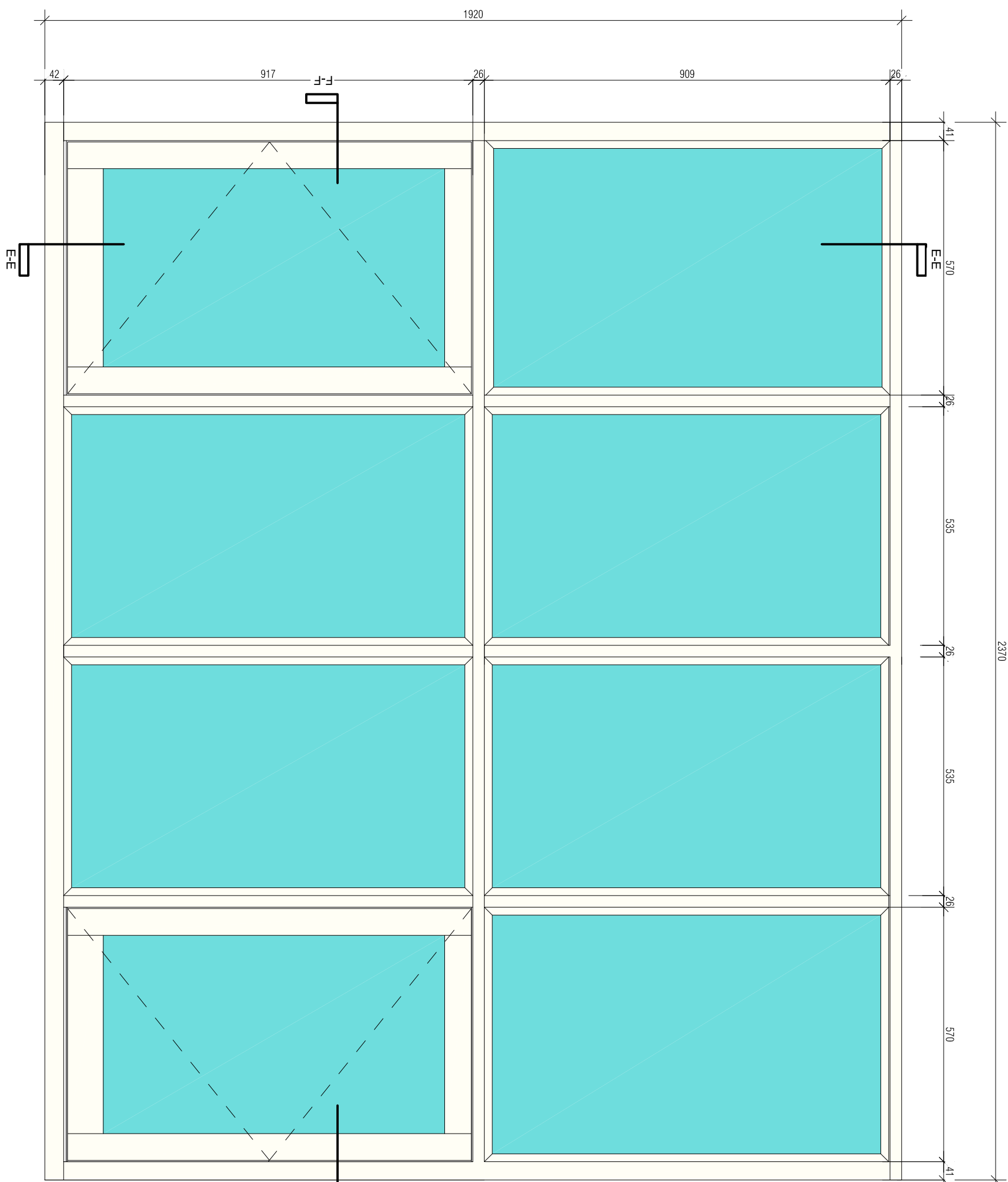

Elevation  
 Scale 1:10

8

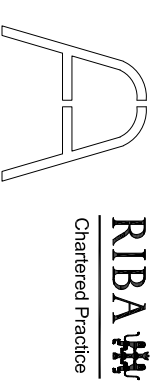

**form:form architects**  
 SUITE 0 FIRST FLOOR  
 11, FINE LINE  
 STREETS, STROUSEBURY, STROUSEBURY, ST17 2BZ  
 T: 01453 743012  
 F: 01453 743013  
 W: formformarchitects.com

CLIENT: Mr and Mrs Pizzo  
 PROJECT: Alterations to The Old Rectory, Llandysall

TITLE:	Replacement Window - Kitchen - Elevation		
DRAWING NO:	REV:	JOB NO:	
308	/	240104	
SCALE:	STATUS:	DOC	
1:10 @ A3	DOC		
DATE: 18/07/24	DRAWN: HB		

REV:	DESCRIPTION:	BY:	DATE:
	Revised to client comments	A	HB 18.03.24

**GENERAL NOTES:**

THE DRAWING IS TO BE CONSIDERED BY A FULL BUILDING REGULATORY AUTHORITY AND THEREFORE ALL WORK SHOWN MUST COMPLY WITH THE CURRENT BUILDING REGULATIONS APPLICABLE TO THE JURISDICTION OF THE LOCAL AUTHORITY BUILDING CONTROL OFFICE UNLESS A DIFFERENT BUILDING REGULATION IS SPECIFIED IN THE CONTRACT. ALL MATERIALS AND COMPONENTS MUST BE SUITABLE FOR THEIR INTENDED PURPOSE AND LOCATION AND MUST BE MANUFACTURED AND INSTALLED IN ACCORDANCE WITH ALL RELEVANT MANUFACTURER'S SPECIFICATIONS AND CODES OF PRACTICE (INCLUDING RELEVANT MANUFACTURER'S SPECIFICATIONS). ALL DRAWINGS TO BE CHECKED ON THE PROJECT COMMENCEMENT OF ANY WORK ON THE DRAWINGS, FLOOR AND CROSSLING LEVELS, AND INDICATED ON THE DRAWING BY ACTUAL DIMENSIONS ON SITE. THE DRAWING IS TO BE COMBINED BY THE ARCHITECT AND OTHER CONSULTANTS' INFORMATION. SPECIFICATIONS AND OTHER CONSULTANTS' INFORMATION. ALL PROPRIETARY SYSTEMS SHOWN ON THE DRAWING ARE TO BE INSTALLED IN ACCORDANCE WITH MANUFACTURER'S SPECIFICATIONS RECOMMENDED BY THE ARCHITECT. ANY PERFORMANCE SPECIFICATIONS SHOWN ON THE DRAWING ARE TO BE BROUGHT TO THE ATTENTION OF THE ARCHITECT. ALL DRAWINGS ARE NOT FOR CONSTRUCTION UNLESS SPECIFICALLY MARKED FOR THE PURPOSE. DO NOT SCALE FROM THE DRAWING. QUERIES TO BE DIRECTED TO THE ARCHITECT.

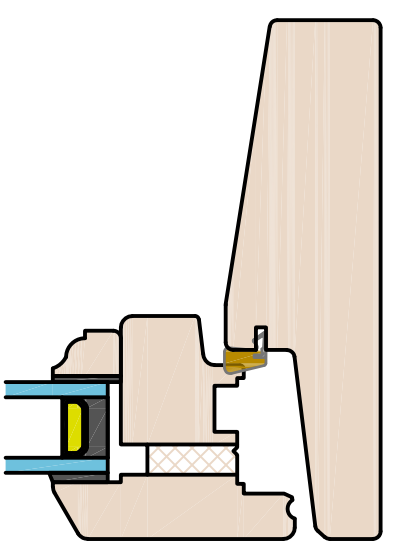

95  
24  
17.5

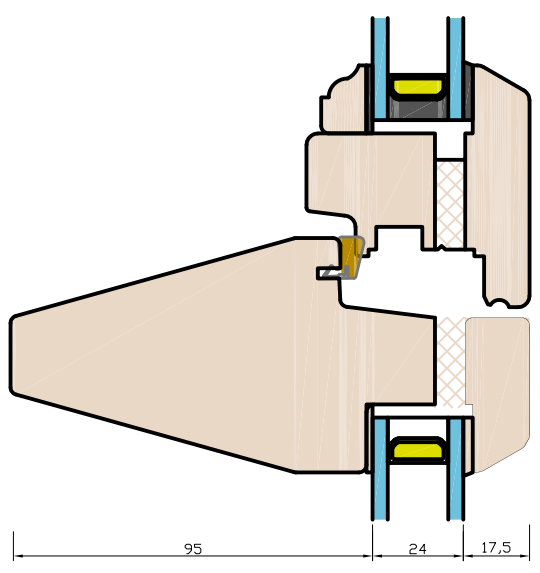
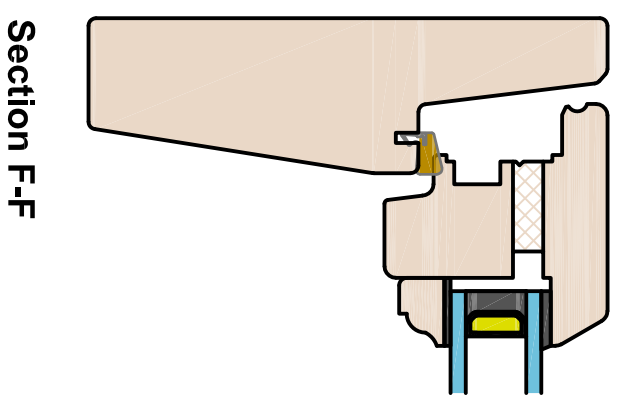
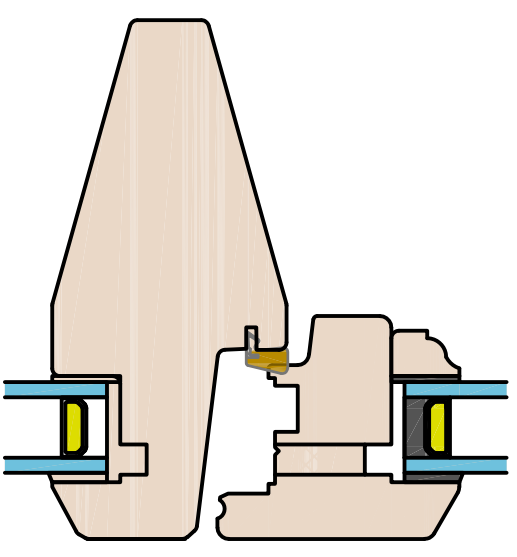

95  
24  
17.5

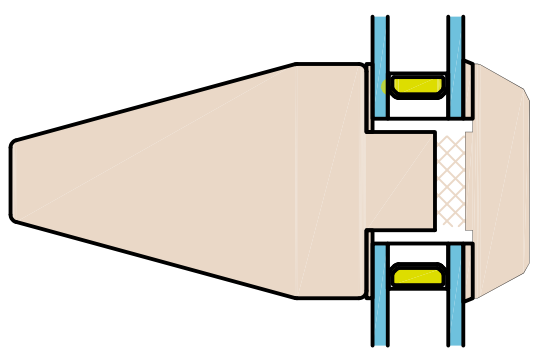

**Section F-F**

Scale 1:2

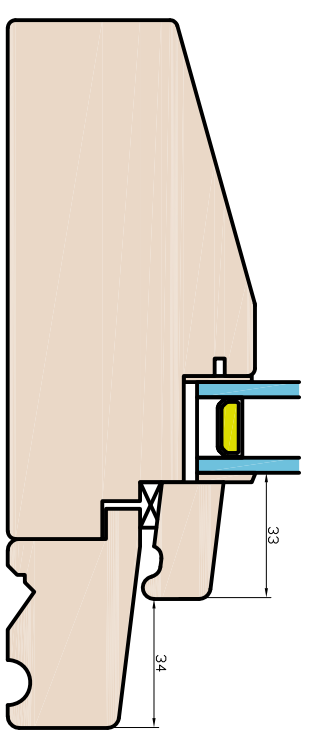

33  
34

**Section E-E**

Scale 1:2

9

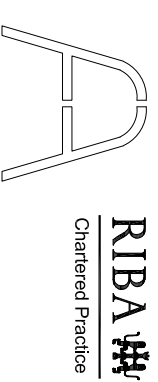

**form:form architects**  
S U I T E 0 1 F I R M F L O O R  
1 1 S H A R P L E Y S T R E E T  
S H R O U S B U R Y, S H R O U S B U R Y, S Y 1 2 8 J  
T : + 4 4 ( 0 ) 1 7 5 3 6 6 1 2 8 0  
F : + 4 4 ( 0 ) 1 7 5 3 6 6 1 2 8 0  
W : f o r m f o r m a r c h i t e c t s . c o m

CLIENT: Mr and Mrs Pizzo  
PROJECT: Alterations to The Old Rectory, Llandysall

TITLE: Replacement Window - Kitchen - Details	REV: /	JOB NO: 240104
DRAWING NO: 309	STATUS: DOC	
SCALE: 1:2 @ A3	DATE: Mar 24	DRAWN: HB

REV: /	DESCRIPTION: Revised to client comments	BY: /	DATE: A HB 18.03.24
--------	-----------------------------------------	-------	---------------------