

Proposed North - East Elevation (1:50)

ROOF:
Spanish Slates. Code 4 Lead throughout. Sarking board to have 3mm gap in between to allow for installation of breather membrane (Daltex Roofsheild). Fascia/Soffits - White

DRAINAGE:
New 68mm Ø PVCu RWP connected into existing drainage, 120mmØ Deepflow RWG - colour: Black. Bracket and support to be fixed at 500mm horizontal centres, 1.8m vertical centres

WINDOWS & DOOR:
Windows to be External White / Internal White Optiwhite argon gas filled double glazed with 'KS' inner pane coating with warm air edge spacer (1.3 W/m²K U-value Windows & 1.4 W/m²K U-value Doors). Opening parts shown. Glass in doors and any adjacent windows to be toughened on inside pane; laminated on outer, designed to resist human impact as set in BS6262 Part 4: 2005. Trickle vents to be fitted to opening sashes as shown to achieve 12000mm² rate of ventilation. 25mm Kingspan insulation to be fitted at window jamb, head and cills to prevent thermal bridging

WALL:
White Blockwork Dry Dashed to Basecourse, Dado & Full Height Wall

FASCIA & SOFFIT:
White uPVC

RAINWATER GOODS:
Black uPVC

Any discrepancies or queries regarding any part of the works to be discussed prior to any affected work being carried out.

Drawings not to be scaled and all sizes to be checked on site.

Lighting / Electrical Items all as per Specification and to final positions to be agreed on site by customer.

ANY Sub floor ventilator covered by works to be re-routed to external air.

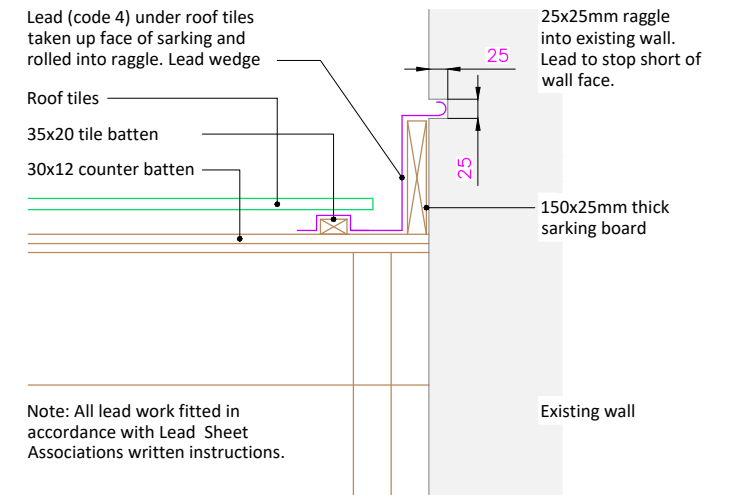

Raggle Details - Tiled Roof (1:10)

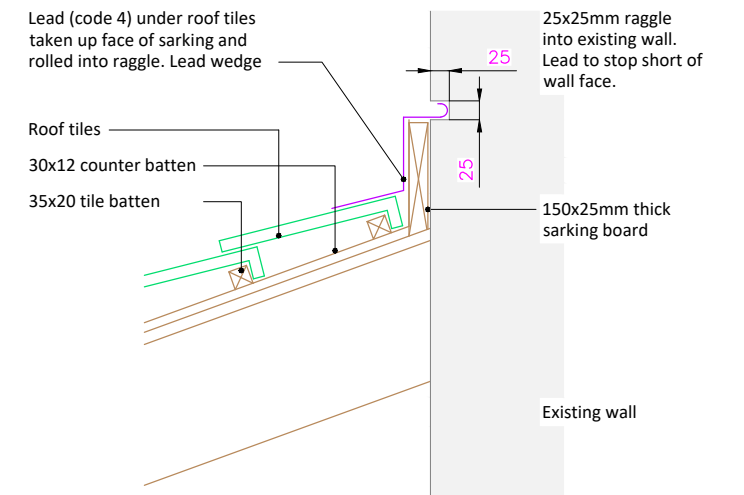

Raggle Details - Tiled Roof (1:10)

GENERAL NOTES

ALL ELECTRICAL WORK TO BE CARRIED OUT IN STRICT ACCORDANCE WITH THE LATEST I.E.E REGULATIONS AND TO COMPLY WITH THE 18TH EDITION OF THE BS 7671: 2018 'THE REQUIREMENTS FOR ELECTRICAL INSTALLATIONS'.

ANY DISCREPANCIES OR QUERIES REGARDING ANY PART OF THE WORKS TO BE DISCUSSED PRIOR TO ANY AFFECTED WORK BEING CARRIED OUT.

WHILST THE HIGHLIGHTED AREAS ARE INDICATIONS OF SERVICES BELOW GROUND THERE MAY BE OTHERS OUT WITH, THEREFORE ALL EXCAVATIONS SHOULD INCORPORATE EXTREME CARE AND DILIGENCE.

DRAWINGS TO BE READ AND UNDERSTOOD PRIOR TO WORK COMMENCING. FIGURED DIMENSIONS TO TAKE PREFERENCE OVER SCALED DIMENSIONS. ALL DIMENSIONS AND LEVELS TO BE CHECKED ON SITE. EXISTING DRAINAGE AND SERVICES POSITIONS TO BE CONFIRMED ON SITE. ANY DISCREPANCIES TO BE REPORTED BACK TO ARCHITECT.

CUSTOMER APPROVAL		
SALES ADVISER		
SALES MANAGER		
APPROVAL	DATE	SIGNATURE

2	ISSUED FOR PLANNING & WARRANT APPROVAL	T.ELLIS	09/04/2024	
1	ISSUED TO CUSTOMER FOR APPROVAL	T.ELLIS	08/03/2024	
0	ISSUED TO SALES FOR APPROVAL	T.ELLIS	29/02/2024	
No.	REVISION	DRAWN BY	CHECKED BY	DATE

CUSTOMER:
MR & MRS BEATTIE
10 DEEMOUNT AVENUE
ABERDEEN
AB11 7UF

PROJECT:
PROPOSED KITCHEN EXTENSION

THISTLE CONTRACT NO: **41447**

THISTLE HOUSE, WOODSIDE ROAD
BRIDGE OF DON, ABERDEEN, AB23 8EF
TEL: 01224 706555 WWW.THISTLE.GROUP

DATE	FEB '24	DRAWING NO:	205
SCALE	1:50		

