

Planning Department
The Royal Borough of Windsor and Maidenhead
Town Hall
St Ives Road
Maidenhead
SL6 1RF

Cheyenne House
West Street
Farnham
Surrey, GU9 7EQ

01252 916655
rosalind@solveplanning.co.uk
solveplanning.co.uk

29th March 2024

Dear Planning Department

Discharge of Condition Application
The Arcade, High Street, Cookham, Maidenhead SL6 9TA

Planning permission was granted on 14th March 2024 under appeal reference APP/T0355/W/23/3329117 for the following development:

Use of the building for office space at The Arcade, High Street, Cookham

This planning permission is subject to a condition requiring the submission of details of bicycle parking facilities as set out below:

Condition 1) Unless within one month of the date of this decision, details of bicycle parking facilities are submitted in writing to the local planning authority for approval, and unless the approved details are implemented within one month of the local planning authority's approval, the occupation of the development shall cease until such time as details are approved and implemented. Upon implementation, the approved bicycle parking facilities specified in this condition shall be permanently retained.

If no details in accordance with this condition are approved within four months of the date of this decision, the occupation of the development shall cease until such time as details approved by the local planning authority have been implemented.

In the event of a legal challenge to this decision, or to a decision made pursuant to the procedure set out in this condition, the operation of the time limits specified in this condition will be suspended until that legal challenge has been finally determined.

A drawing showing the position of the Sheffield stand which will provide the required cycle parking facility to serve the approved use of the building. The Sheffield stand is compliant with the requirements of planning policy and allows flexibility in the number and type of bicycles that can be parked here.

The stand will be positioned to the left, inside of the entrance gate to the site and set 1m from the fence to allow sufficient space for the bicycles to access the stand. This accords with the requirements of the Council in respect of cycle parking.

Detailed specification of the Sheffield stand are also included below:

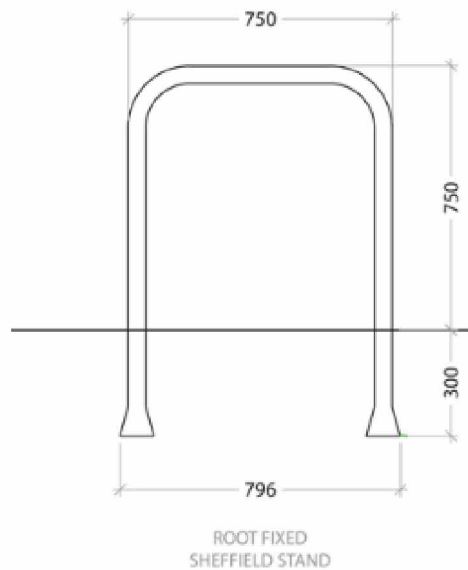

I trust the above and accompanying documents provide sufficient information to enable the application to be registered but please let me know if you require anything further.

Yours sincerely



**Rosalind Graham BA Hons DipTP MRTPI
Associate**

