

Proposed Roof Plan 1:200

NOTES
Internal dimensions are finished sizes unless otherwise stated.

REVISION SCHEDULE

Rev	Description	Date
A	Development site boundary adjusted to include the access to the site	22.03.24

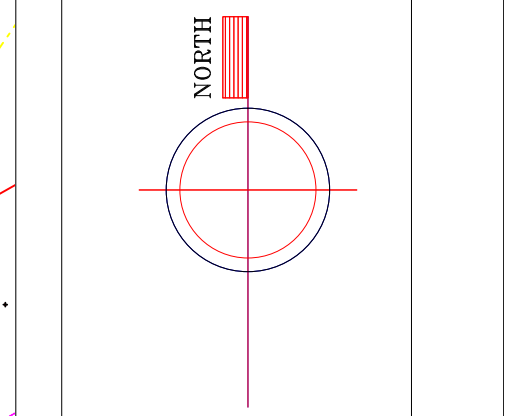

PLANNING PERMISSION APPLICATION

DO NOT SCALE FROM DRAWING :: SITE CHECK DIMENSIONS
All dimensions to be site checked by the Contractor and all discrepancies to be advised to the Architect prior to the work being commenced.
Use stated dimensions only.
This Drawing Is Copyright.

This is the drawing referred to in my application
Dated :: *11th March 2024*
Signed :: *Eric McMillan*

CLIENT :: **Mr Will Oakley**

PROJECT :: **3 Mains Road
Ballantrae
South Ayrshire
KA26 0NJ**

DRAWING :: **Proposed Site Plan Over
Topographical Plan**

Scale 1:200	Date 12/01/24	Drawn by emcm
Job No. 22022	Drawing No. DD 105	Revision No. A

McMILLAN & CRONIN
chartered architects & planning consultants
24 MAIN STREET, LARGS :: KA30 8AB
tel. (44) 01475 686818
fax. (44) 01475 686331
mail@mcmillancronin.co.uk