

THE OLD BAKEHOUSE

The Old Bakehouse, Six Bells Lane, Sevenoaks, Kent TN13 1JE.

The drawing is copyright of SIXTHART LTD. This drawing shall not be scaled. All dimensions are in mm unless otherwise stated. All dimensions shall be checked on site prior to commencing the works and any discrepancies to be reported to SIXTHART LTD. All works shall conform to the current edition of the building regulations and other statutory requirements. All materials and workmanship shall conform with the relevant British Standard specifications and codes of practice. If this drawing forms part of an application for planning permission, it shall not be used for any other purpose without the express permission of SIXTHART LTD. This drawing may incorporate information from other professionals. SIXTHART LTD cannot accept responsibility for the integrity and accuracy of such information. Any clarification and/or additions that are required appertaining to such information should be sought from the relevant profession or their appointment representative.

Drawings, specifications and schedules are to be read in conjunction with the following where applicable: Employer's Requirements documents, Agreements to Lease, Structural Engineer's drawings and specifications, Civil Engineer's drawings and specifications, Survey Drawings, Party Wall/Boundary Awards. Other specialist design consultant's requirements as appointed by the Main Contractor. Other specialist design sub-contractor's requirements as appointed by the Main Contractor.

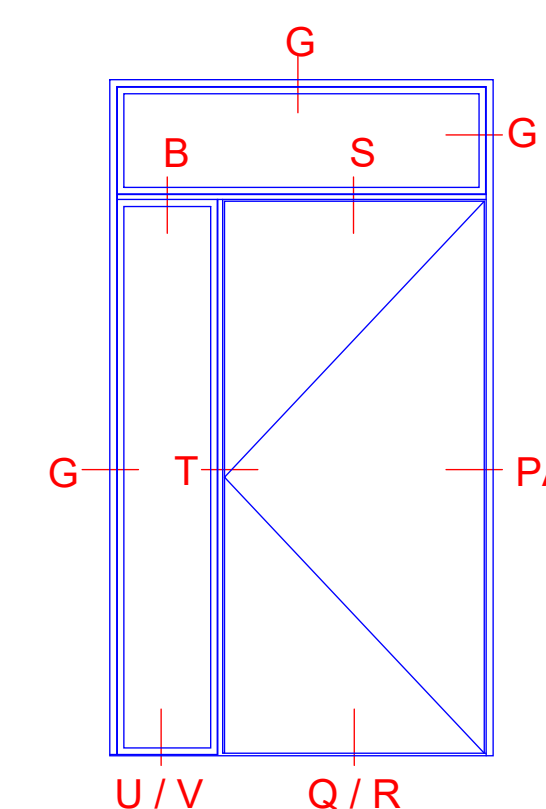
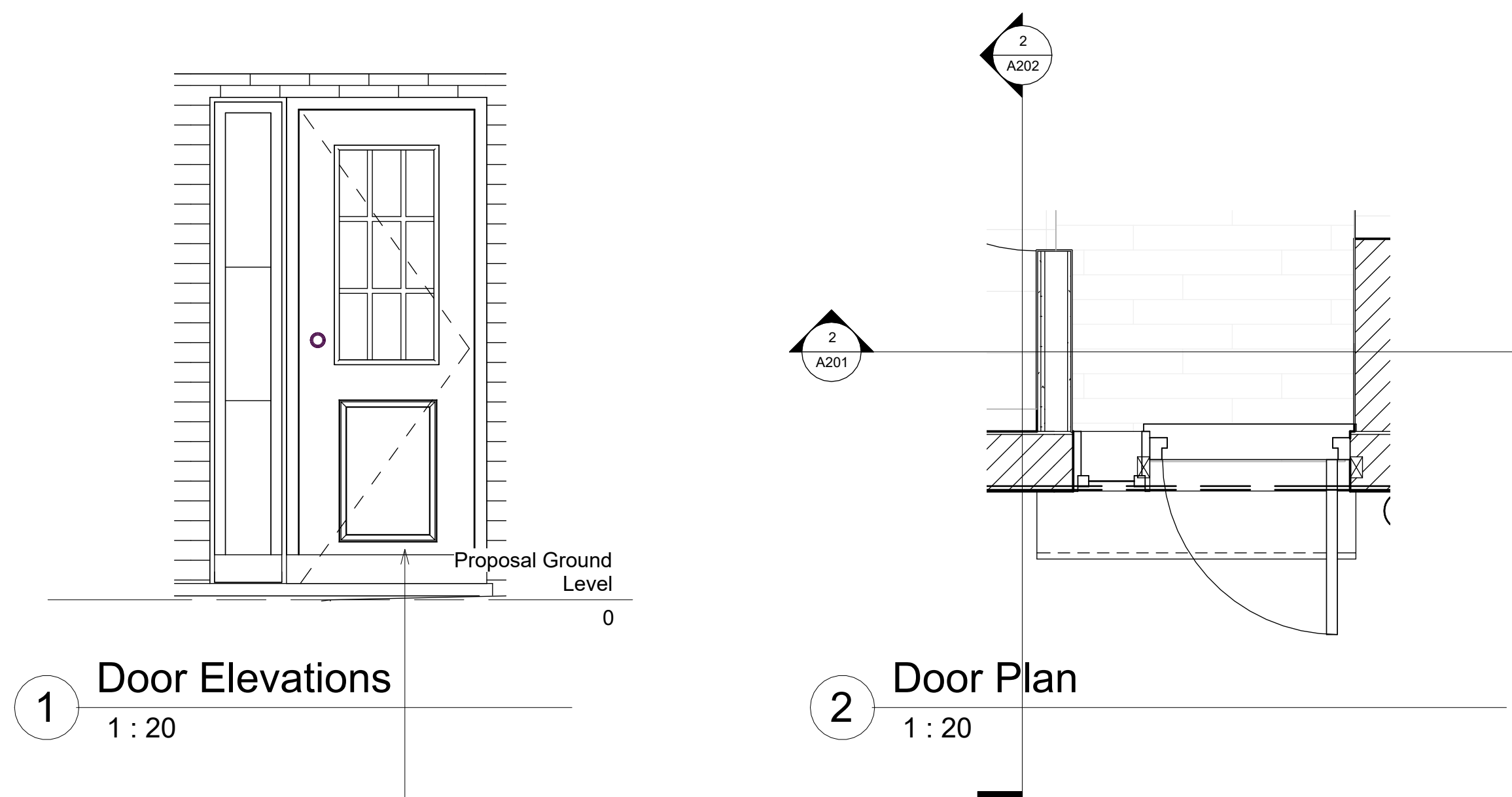
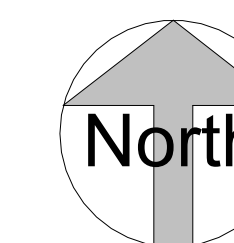

All new doors and windows will perfectly match the colors of the main house windows and doors.

NEW AND REPLACEMENT DOORS

New and replacement doors to achieve a U-Value of 1.4W/m²K. Glazed areas to be double glazed with 16-20mm argon gap and soft low-E glass. Glass to be toughened or laminated safety glass to BS 6206, BS EN 14179 or BS EN ISO 12543-1 and Part K (Part N in Wales) of the current Building Regulations.

Insulated plasterboard to be used in reveals to abut jambs and to be considered within reveal soffits. Fully insulated and continuous cavity closers to be used around reveals.

Windows and door frames to be taped to surrounding openings using air sealing tape.

INTERNAL DOORS

A lintel suitable for the loads above will be required; a single door will generally require a 150mm deep concrete lintel with 100mm bearings onto masonry.

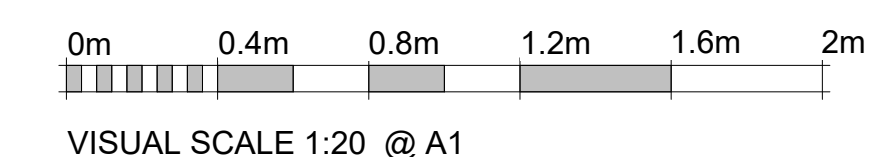
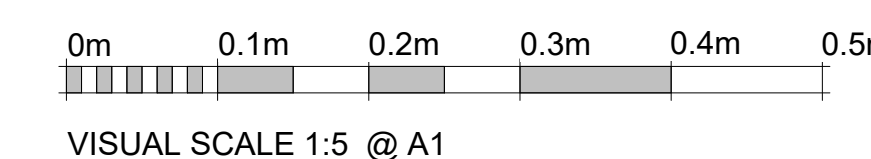

TN13 1JE

Conversion of existing outbuildings of the Old Bakehouse into a one-bedroom annexe.

TITLE		
DOOR DETAILS		
DATE	SCALE	PROJECT NUMBER
Issue Date	1:20	Project Number
STAGE	REVISION	DRAWING NO
BC		DG-115

SIXTHART
ARCHITECTURAL DESIGN STUDIO
12 EATON ROW SW1W 0JA
LONDON UK
www.sixthart.co.uk
erhan@sixthart.co.uk

THE OLD BAKEHOUSE

**The Old Bakehouse,
Six Bells Lane, Sevenoaks,
Kent
TN13 1JE.**

The drawing is copyright of SIXTHART LTD. This drawing shall not be scaled. All dimensions are in mm unless otherwise stated. All dimensions shall be checked on site prior to commencing the works and any discrepancies to be reported to SIXTHART LTD. All works shall conform to the current edition of the building regulations and other statutory requirements. All materials and workmanship shall conform with the relevant British Standard specifications and codes of practice. If this drawing forms part of an application for planning permission, it shall not be used for any other purpose without the express permission of SIXTHART LTD. This drawing may incorporate information from other professionals. SIXTHART LTD cannot accept responsibility for the integrity and accuracy of such information. Any clarification and/or additions that are required appertaining to such information should be sought from the relevant profession or their appointment representative.

Drawings, specifications and schedules are to be read in conjunction with the following where applicable: Employer's Requirements documents, Agreements to Lease, Structural Engineer's drawings and specifications, Civil Engineer's Party Wall/Boundary Awards. Other specialist design consultant's requirements as appointed by the Main Contractor. Other specialist design sub-contractor's requirements as appointed by the Main Contractor.

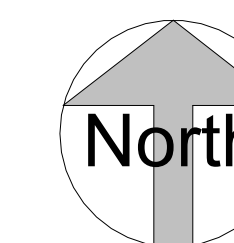

All new doors and windows will perfectly match the colors of the main house windows and doors.

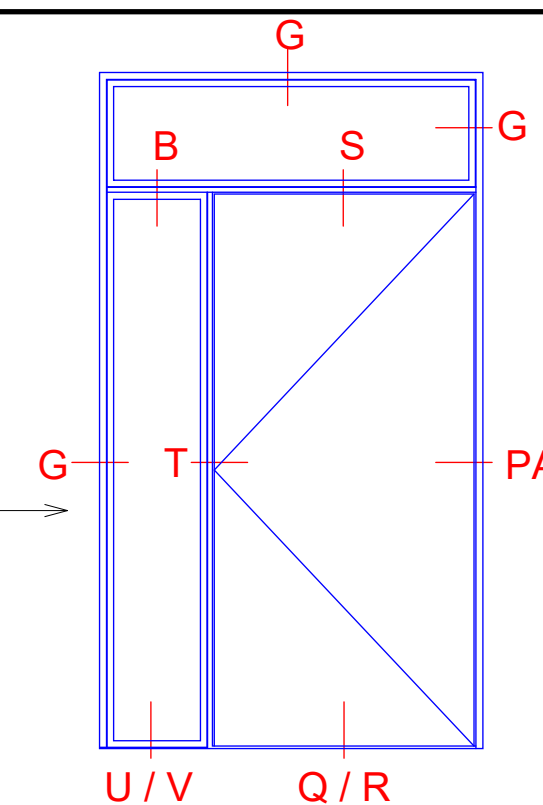

PB: (3014.0583)

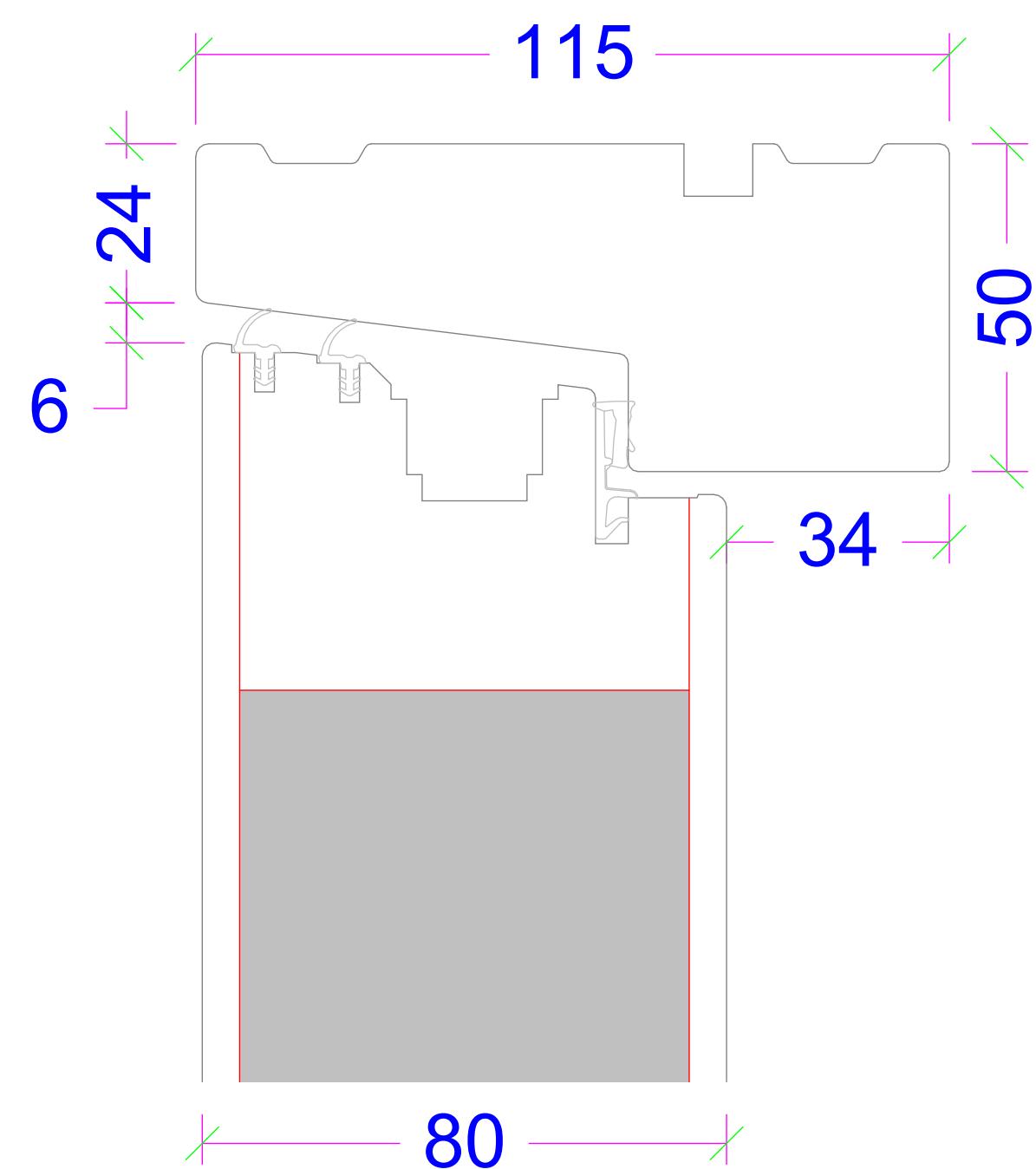

PA: (3014.2333)

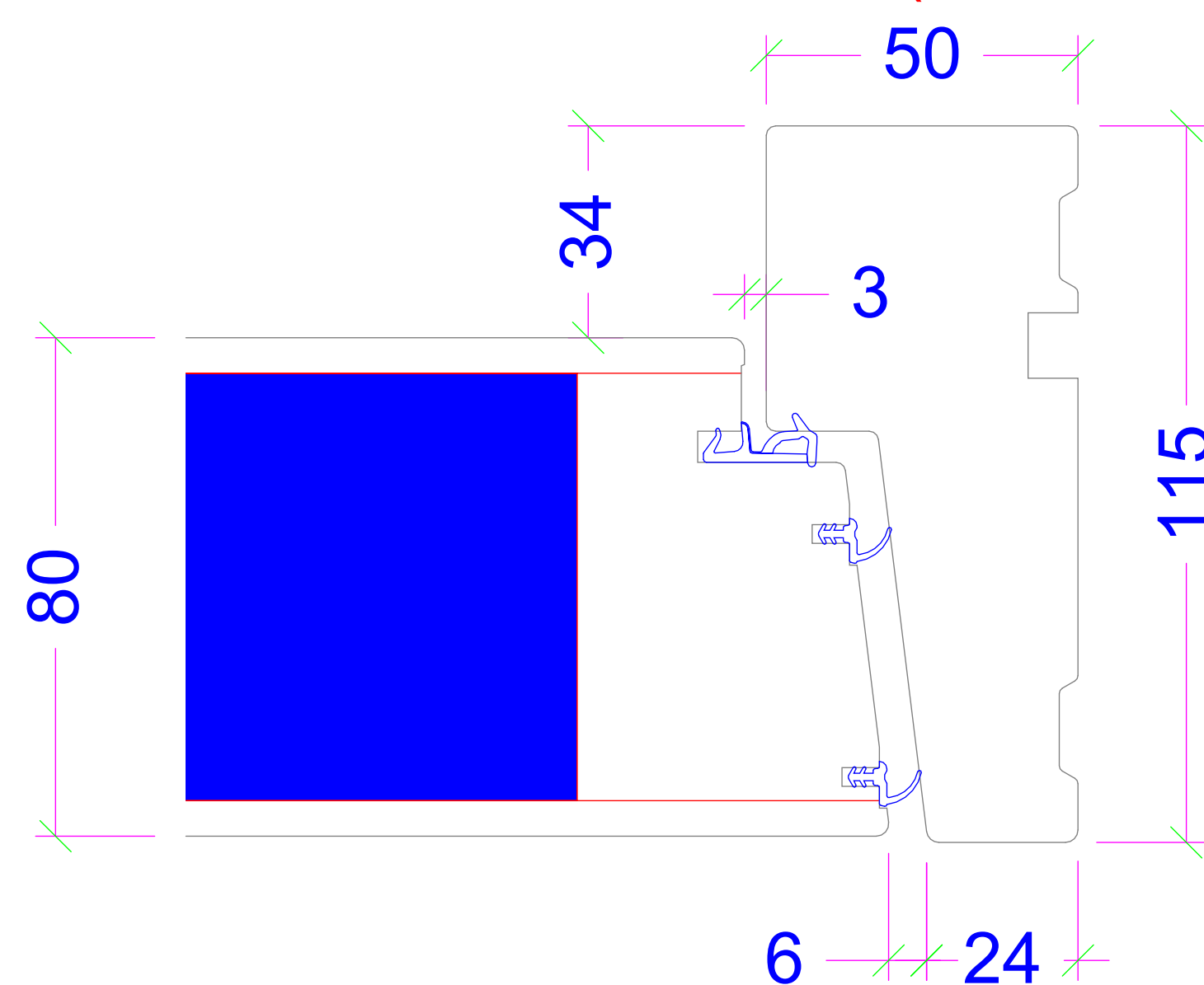

**R: (3014.0574)
(Alu and wood)**

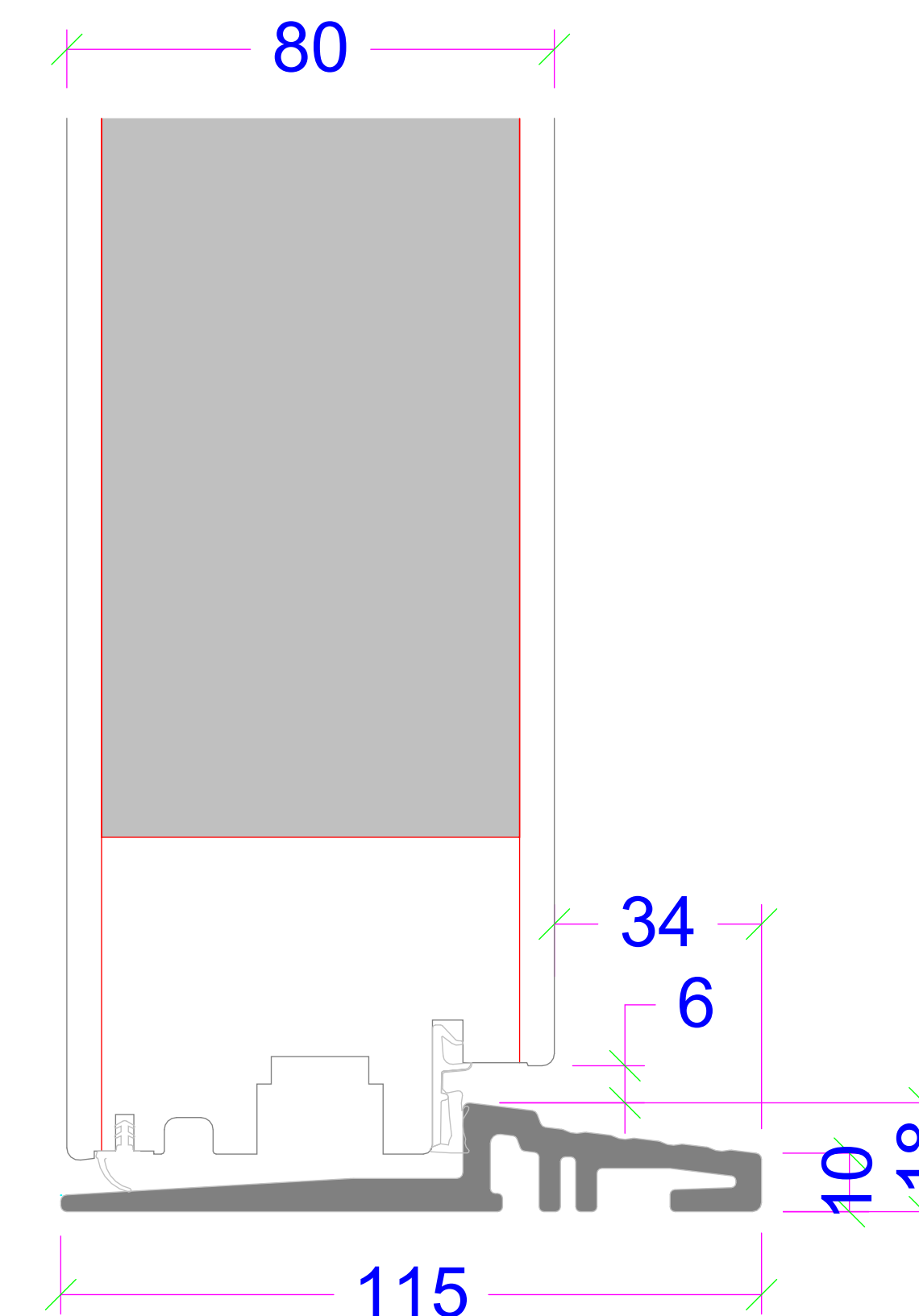

**B: (3014.1916)
(Window and sidelight)**

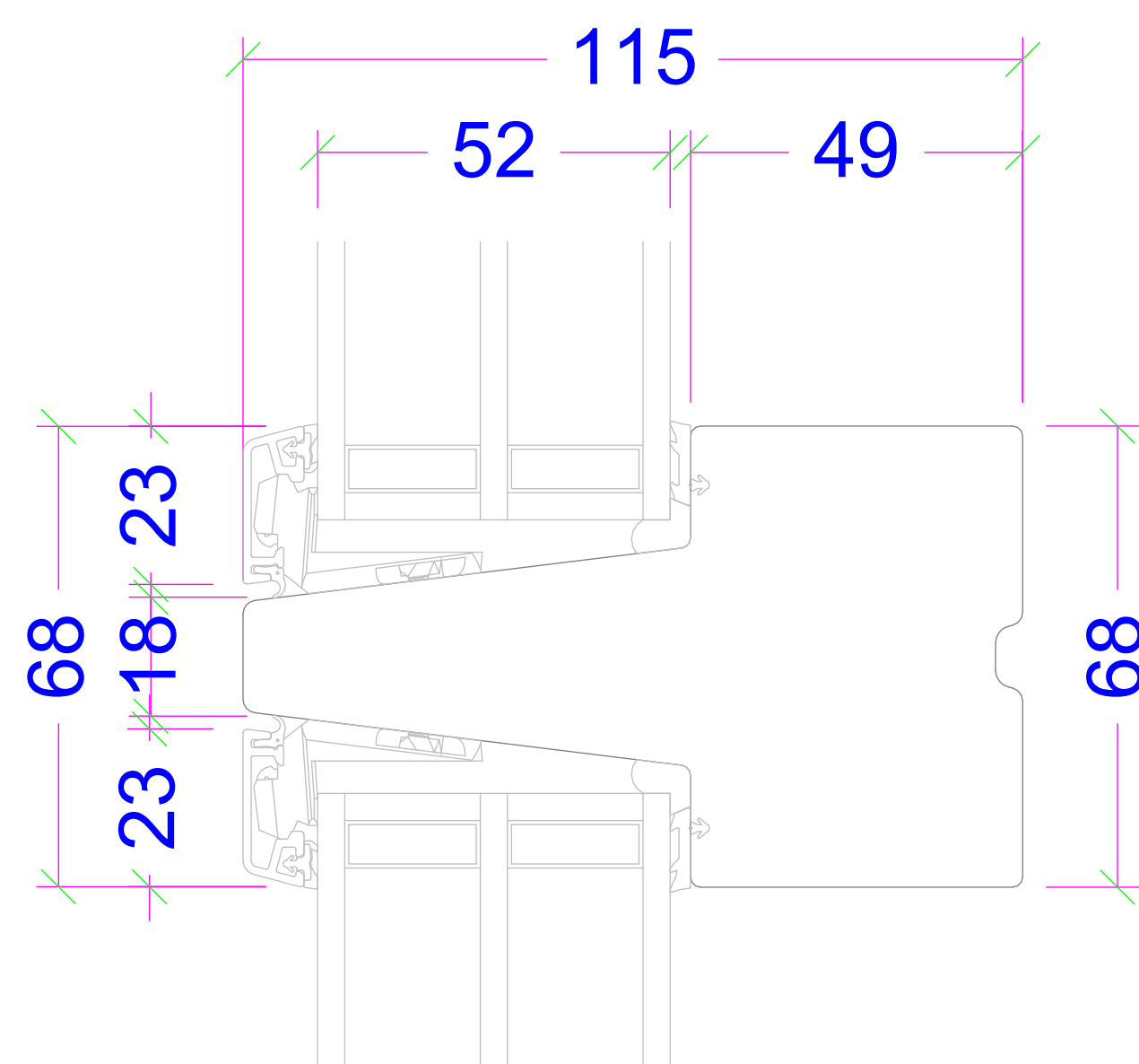

**G: (3014.1913)
(Window and sidelight / glazed / flush)**

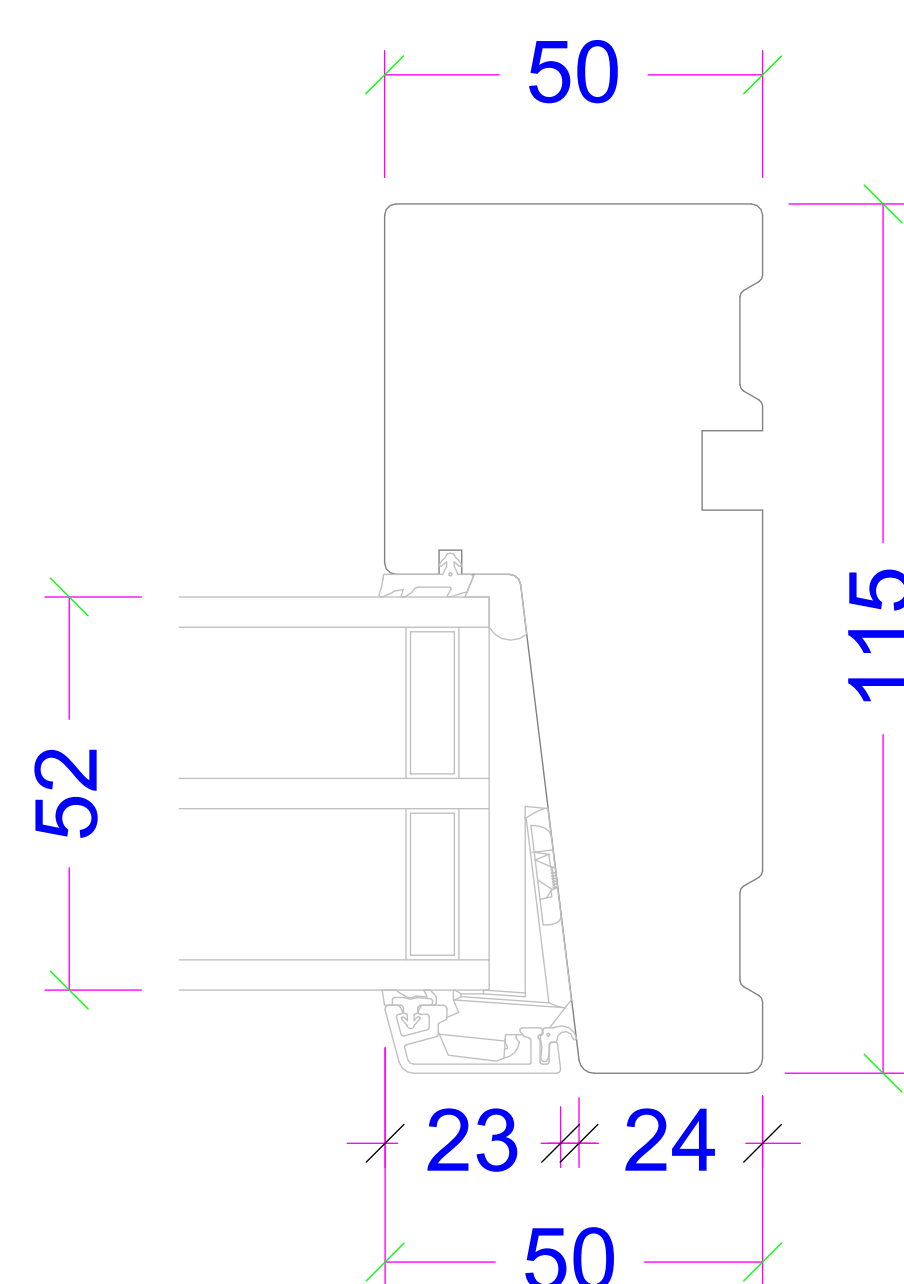

**U: (3014.2079)
(Alu and wood)**

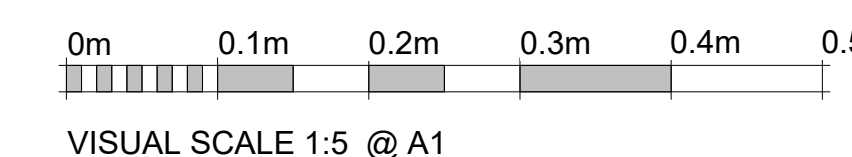
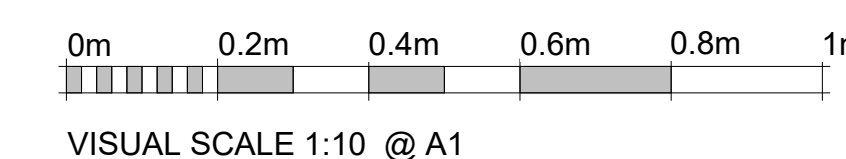
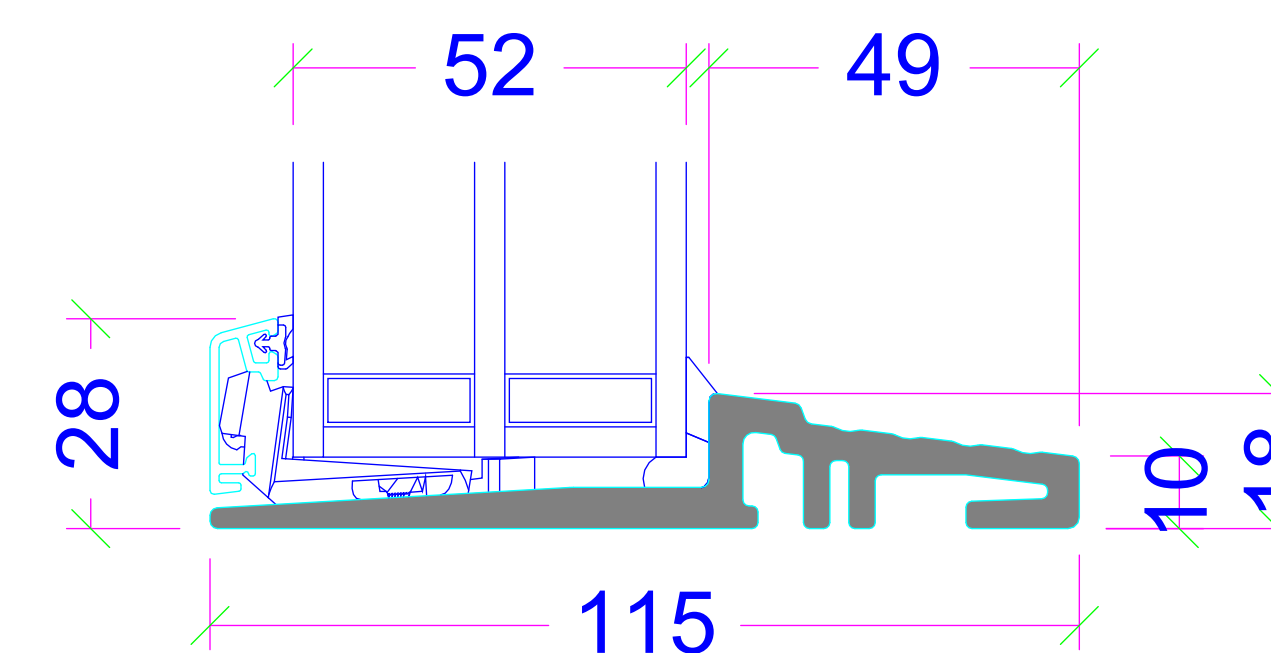

TN13 1JE

Conversion of existing outbuildings of the Old Bakehouse into a one-bedroom annexe.

TITLE		
DOOR DETAILS 1		
DATE	SCALE	PROJECT NUMBER
Issue Date		Project Number
STAGE	REVISION	DRAWING NO
BC		DG-115

**SIXTHART
ARCHITECTURAL DESIGN STUDIO**
12 EATON ROW SW1W 0JA
LONDON UK
www.sixthart.co.uk
erhan@sixthart.co.uk

THE OLD BAKEHOUSE

The Old Bakehouse,
Six Bells Lane, Sevenoaks,
Kent
TN13 1JE.

The drawing is copyright of SIXTHART LTD. This drawing shall not be scaled. All dimensions are in mm unless otherwise stated. All dimensions shall be checked on site prior to commencing the works and any discrepancies to be reported to SIXTHART LTD. All works shall conform to the current edition of the building regulations and other statutory requirements. All materials and workmanship shall conform with the relevant British Standard specifications and codes of practice. If this drawing forms part of an application for planning permission, it shall not be used for any other purpose without the express permission of SIXTHART LTD. This drawing may incorporate information from other professionals. SIXTHART LTD cannot accept responsibility for the integrity and accuracy of such information. Any clarification and/or additions that are required appertaining to such information should be sought from the relevant profession or their appointment representative.

Drawings, specifications and schedules are to be read in conjunction with the following where applicable: Employer's Requirements documents, Agreements to Lease, Structural Engineer's drawings and specifications, Civil Engineer's Party Wall/Boundary Awards. Other specialist design consultant's requirements as appointed by the Main Contractor. Other specialist design sub-contractor's requirements as appointed by the Main Contractor.

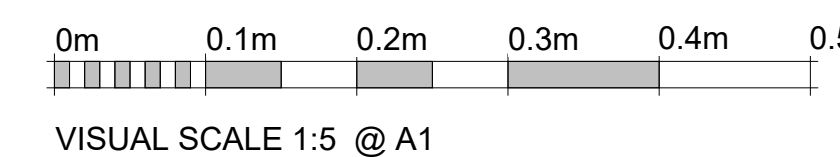
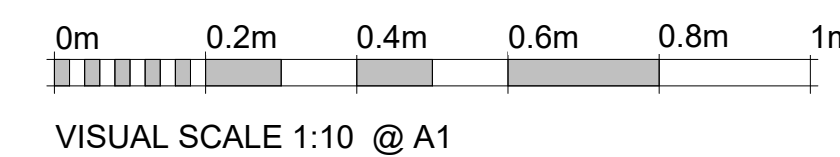
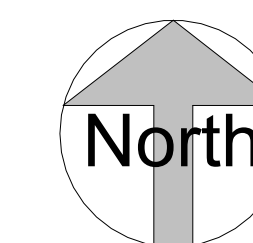

TN13 1JE

Conversion of existing outbuildings of the Old Bakehouse into a one-bedroom annexe.

TITLE		
DOOR DETAILS 2		
DATE	SCALE	PROJECT NUMBER
Issue Date		Project Number
STAGE	REVISION	DRAWING NO
BC		DG-115

SIXTHART
ARCHITECTURAL DESIGN STUDIO
12 EATON ROW SW1W 0JA
LONDON UK
www.sixthart.co.uk
erhan@sixthart.co.uk

15/04/2024 15:11:11

V: (3014.2358)
(Wood - glazed / flush)

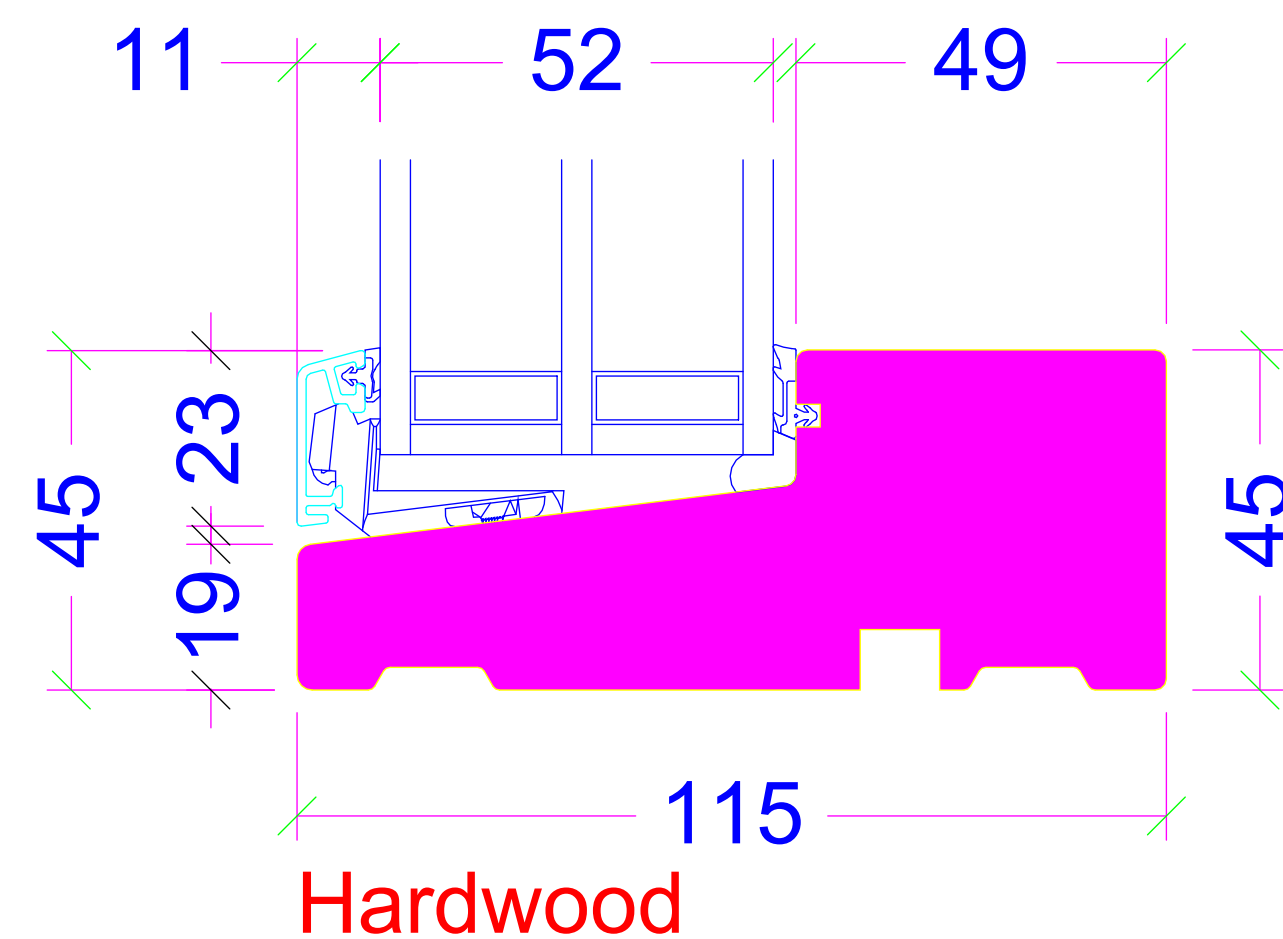

Q: (3014.0855)

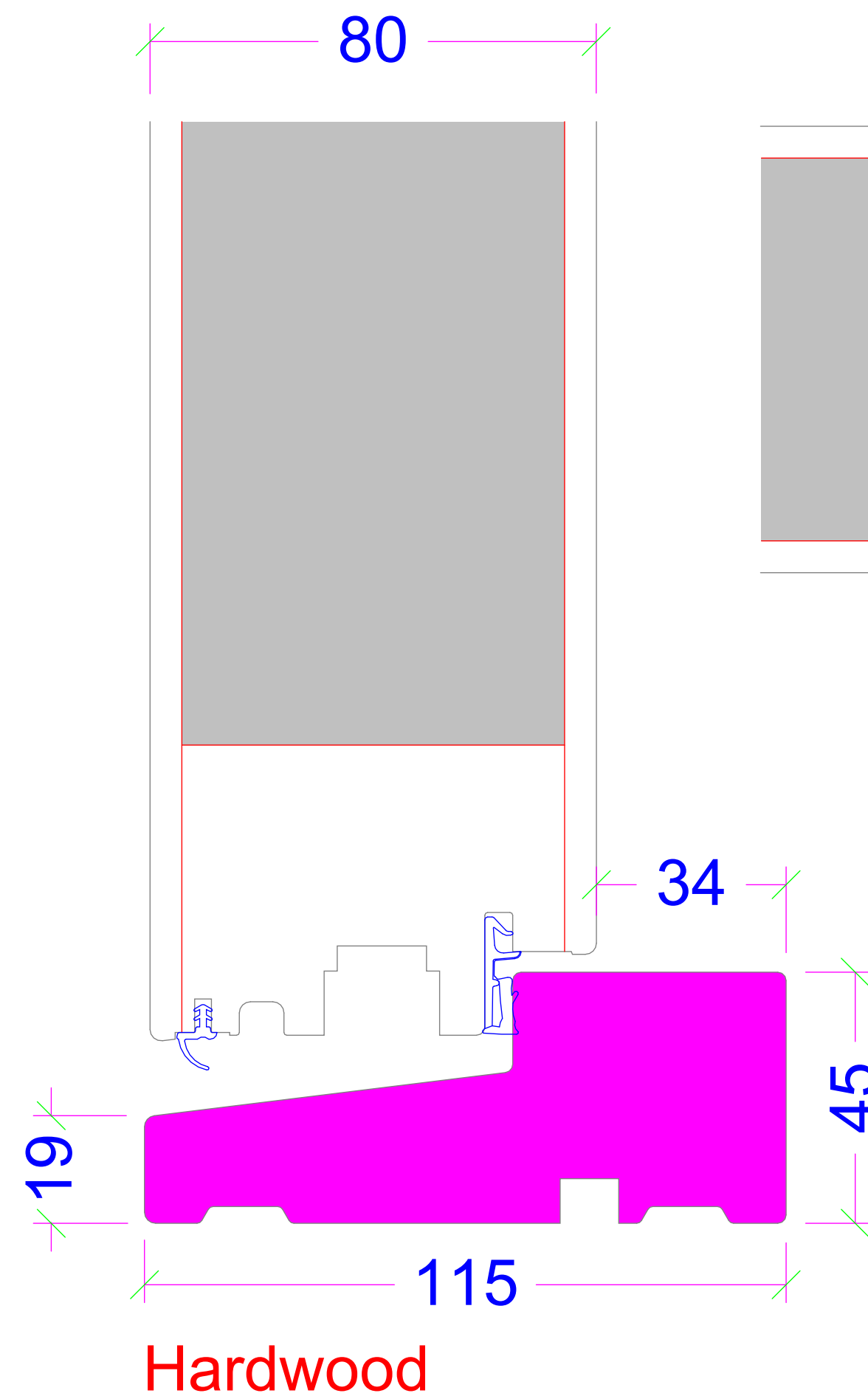

X: (3014.2335)
(Alu and wood)

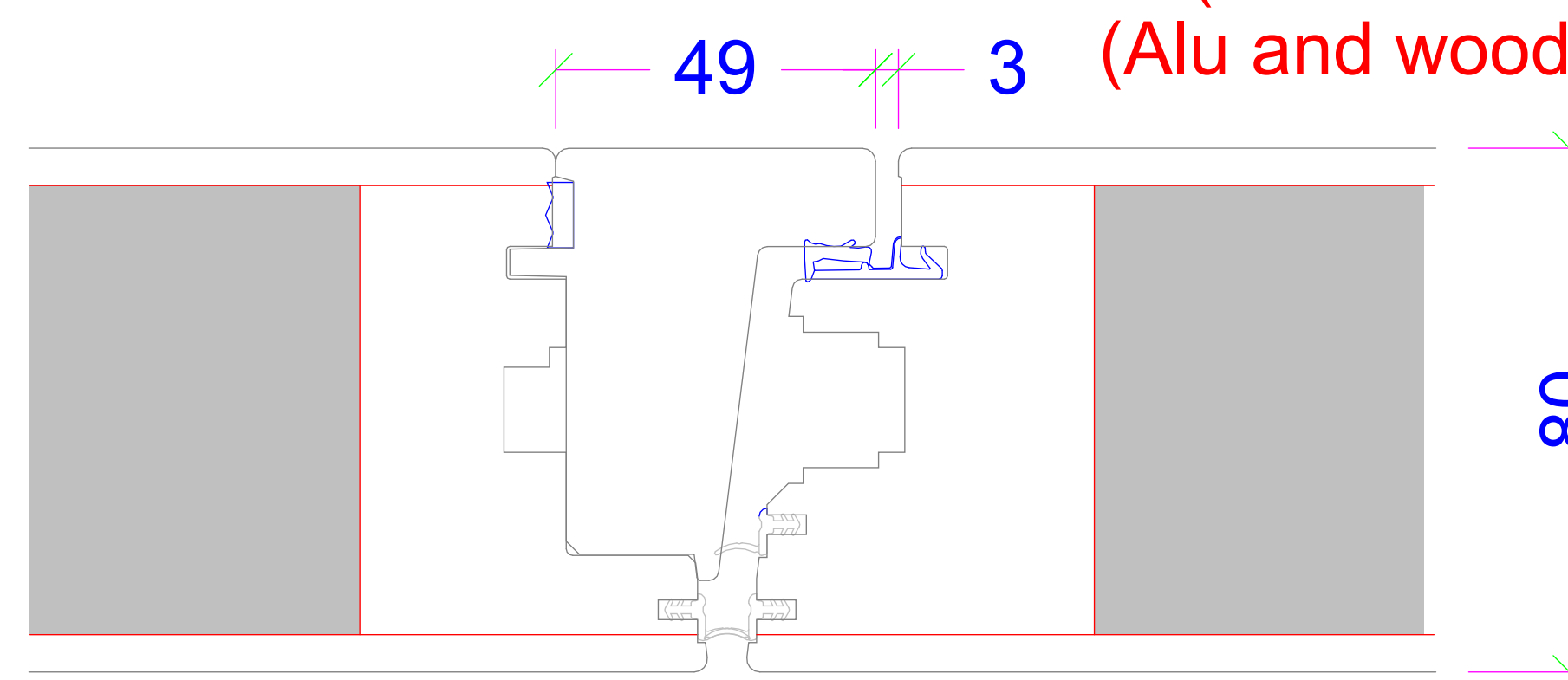

S: (3014.2337)

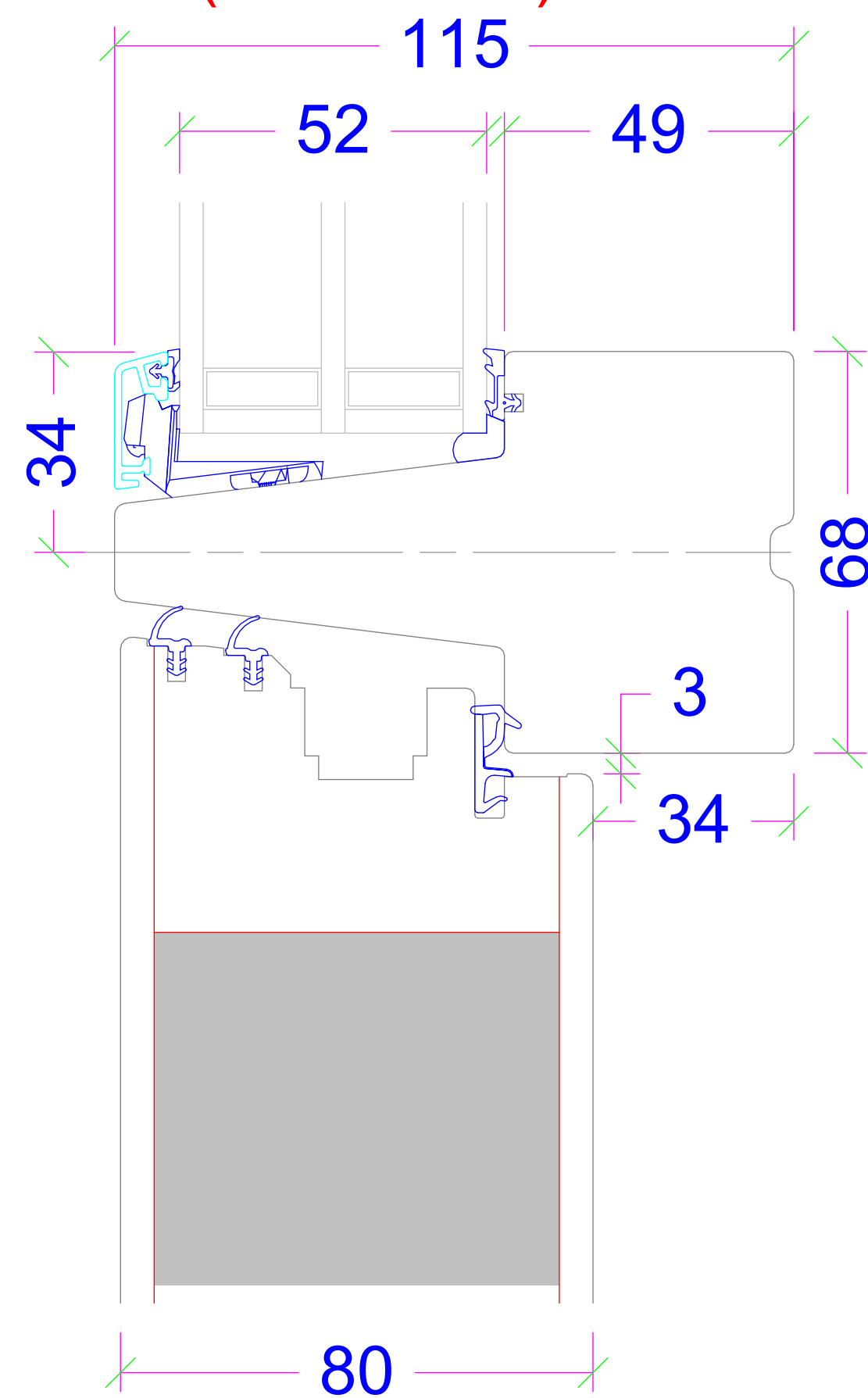

T: (3014.2338)

