

2489: Proposed replacement dwelling at
Tattershall Road,
Billinghay, LN4 4BP

SDA

STEVEN DUNN ARCHITECTS

T: 01526 860757 E: steve@stevendunnarchitects.co.uk
HADLEIGH HOUSE, HIGH STREET, WALCOTT, LINCOLN, LN43SN

Tree Protection Fencing

- The protective fencing for this site should be located as shown on the Tree Protection Plan (drawing 2489-A3-06b) - as illustrated with a thick purple line.
- The precise fencing location may need to be slightly adjusted on site due to site conditions but is not expected to differ from that shown on the TPP. The final fencing position must be agreed by the LPA before the commencement of any site works.
- The protective fencing will be appropriate to the degree and proximity of likely construction works. In this instance, the default BS 5837:2012 tree protection fencing is deemed disproportionate. It is suggested (if acceptable by the LPA) an adequate level of protection for the trees could be provided by 'Heras' type fencing, of welded mesh panels on rubber or concrete feet.
- The fencing should be joined together using a minimum of two anti-tamper couplers, installed so that they can only be removed from inside the fence. The fencing panels should be supported on the inner side by stabilizer struts, which should normally be attached to a base plate secured with ground pins or mounted on a block tray (see Appendix 1 for an example).
- The area enclosed by the fencing is referred to as the Construction Exclusion Zone (CEZ); this area should be considered a restricted area. No pedestrians, vehicles, storage of materials, equipment or machinery should be allowed within the CEZ. The site manager must ensure that all personnel are aware of the restrictions that apply to the fenced-off area.
- Once the fencing is erected, waterproof warning signs labelled 'Tree Protection Area' should be placed at 3m intervals to ensure that all personnel are aware of the restrictions that apply to the fenced-off area.
- The protective fencing should be inspected for faults or damage by the site manager or other responsible named person on a regular basis and a written record kept. Any faults or defects should be repaired or replaced as soon as is reasonably practicable. The Tree Protection Fencing shall not be removed, breached or altered without prior written authorisation from the local planning authority and under arboricultural supervision by a suitable named responsible individual appointed by the site manager.

2489: Proposed replacement dwelling at
Tattershall Road,
Billinghay, LN4 4BP

SDA

STEVEN DUNN ARCHITECTS

T: 01526 860757 E: steve@stevendunnarchitects.co.uk
HADLEIGH HOUSE, HIGH STREET, WALCOTT, LINCOLN, LN43SN

Tree Protection Fencing

APPENDIX 1:

Example of Tree Protection Fencing

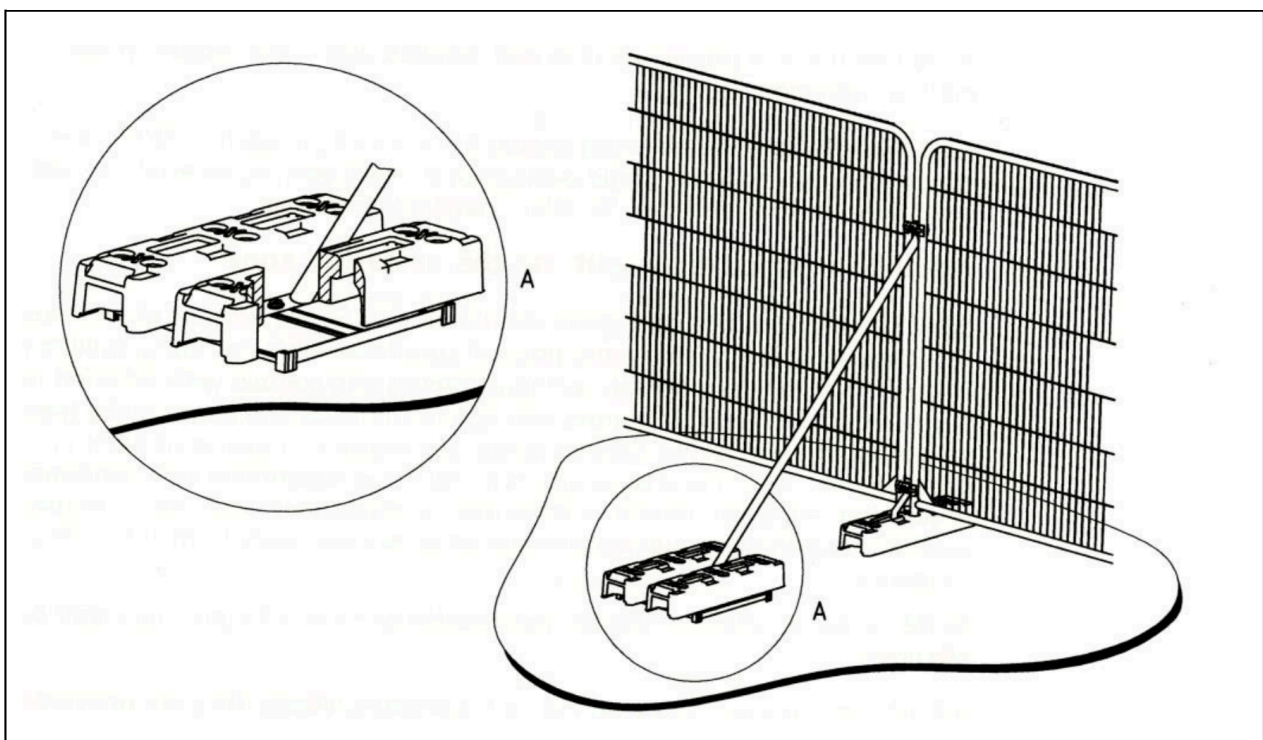
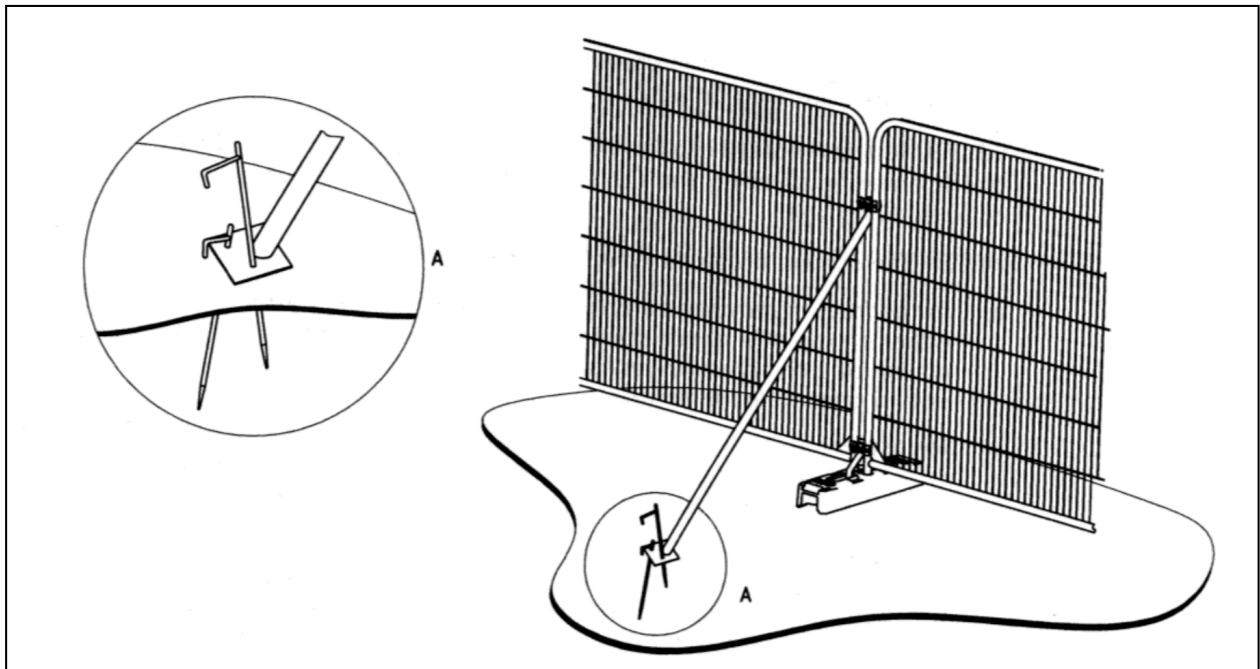

2489: Proposed replacement dwelling at
Tattershall Road,
Billinghay, LN4 4BP

SDA

STEVEN DUNN ARCHITECTS

T: 01526 860757 E: steve@stevendunnarchitects.co.uk
HADLEIGH HOUSE, HIGH STREET, WALCOTT, LINCOLN, LN43SN

Tree Protection Fencing

APPENDIX 2:

Example of Tree Protection Signage

