

- Notes:
1. ALL CONSTRUCTION DETAILS TO COMPLY WITH SOUTH LANARKSHIRE COUNCIL, ROADS DEVELOPMENT GUIDE AND THE DESIGN MANUAL FOR ROADS AND BRIDGES.
 2. THE SPECIFICATION FOR THIS PROJECT IS THE SPECIFICATION FOR HIGHWAY WORKS.
 3. ALL DRAINAGE TO COMPLY WITH "SEWERS FOR SCOTLAND 4"
 4. ALL STORM AND FOUL SEWERS TO BE JETTED ON COMPLETION AND CCTV INSPECTION CARRIED OUT.
 5. ALL STORM AND FOUL SEWERS TO BE ADOPTED BY SCOTTISH WATER.
 6. SURFACE WATER DRAINAGE HAS BEEN DESIGNED TO INCORPORATE THE REQUIREMENTS OF CIRIA DOCUMENT "THE SUDS MANUAL" C753. PIPE DRAINAGE COMPLIES WITH SEWERS FOR SCOTLAND 4 AND BS EN 752: 2008
 7. FOUL WATER DRAINAGE DESIGNED TO COMPLY WITH SEWERS FOR SCOTLAND 4.

SUDS BASIN
 Contributing Area = 10,090 sqm
 Treatment Volume
 0.015 x 10,090sqm = 151.35 cum
 12 Hour Drain Down Flow
 151.35 x 1000 / 12 / 3600 = 3.5/s

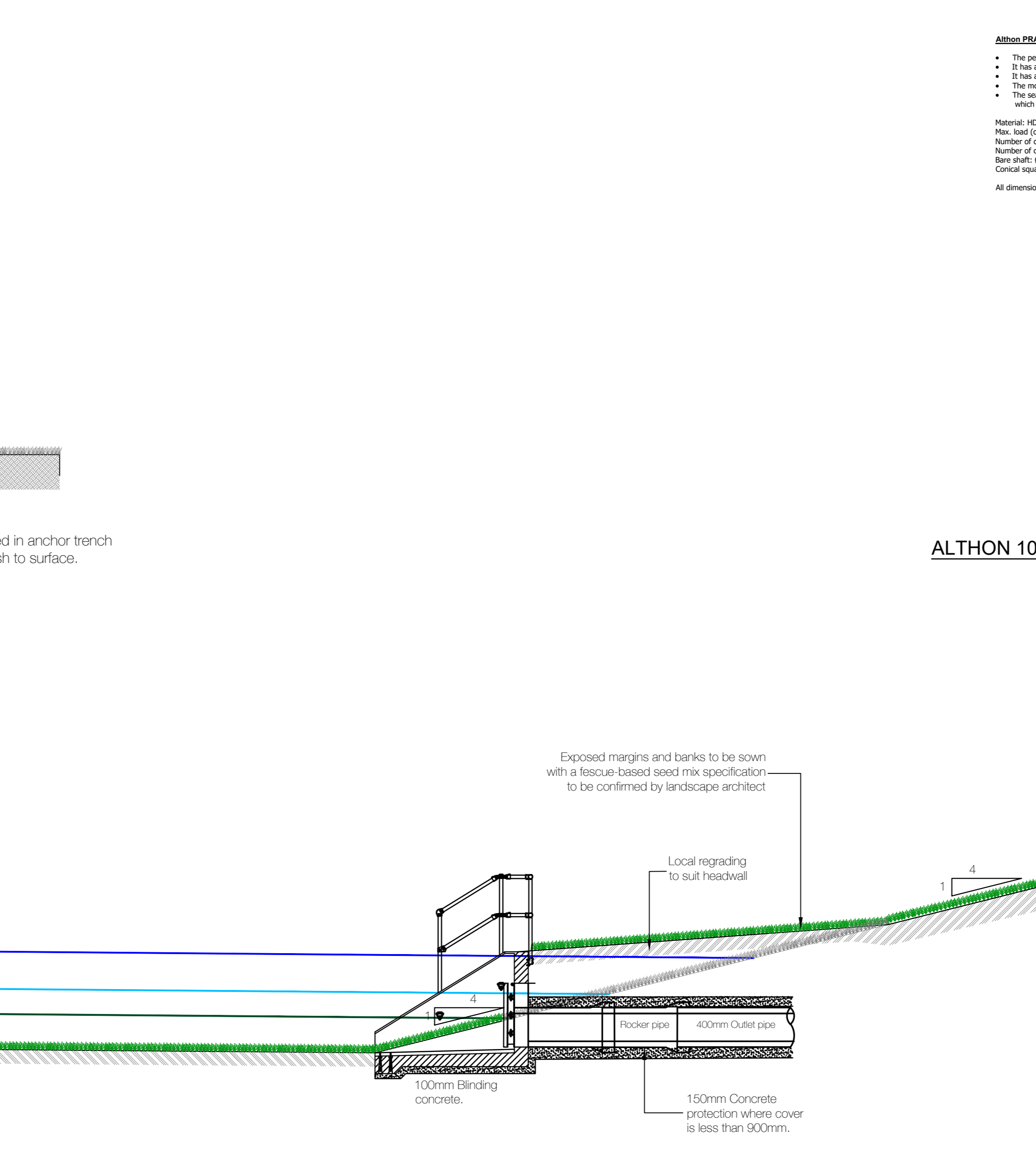
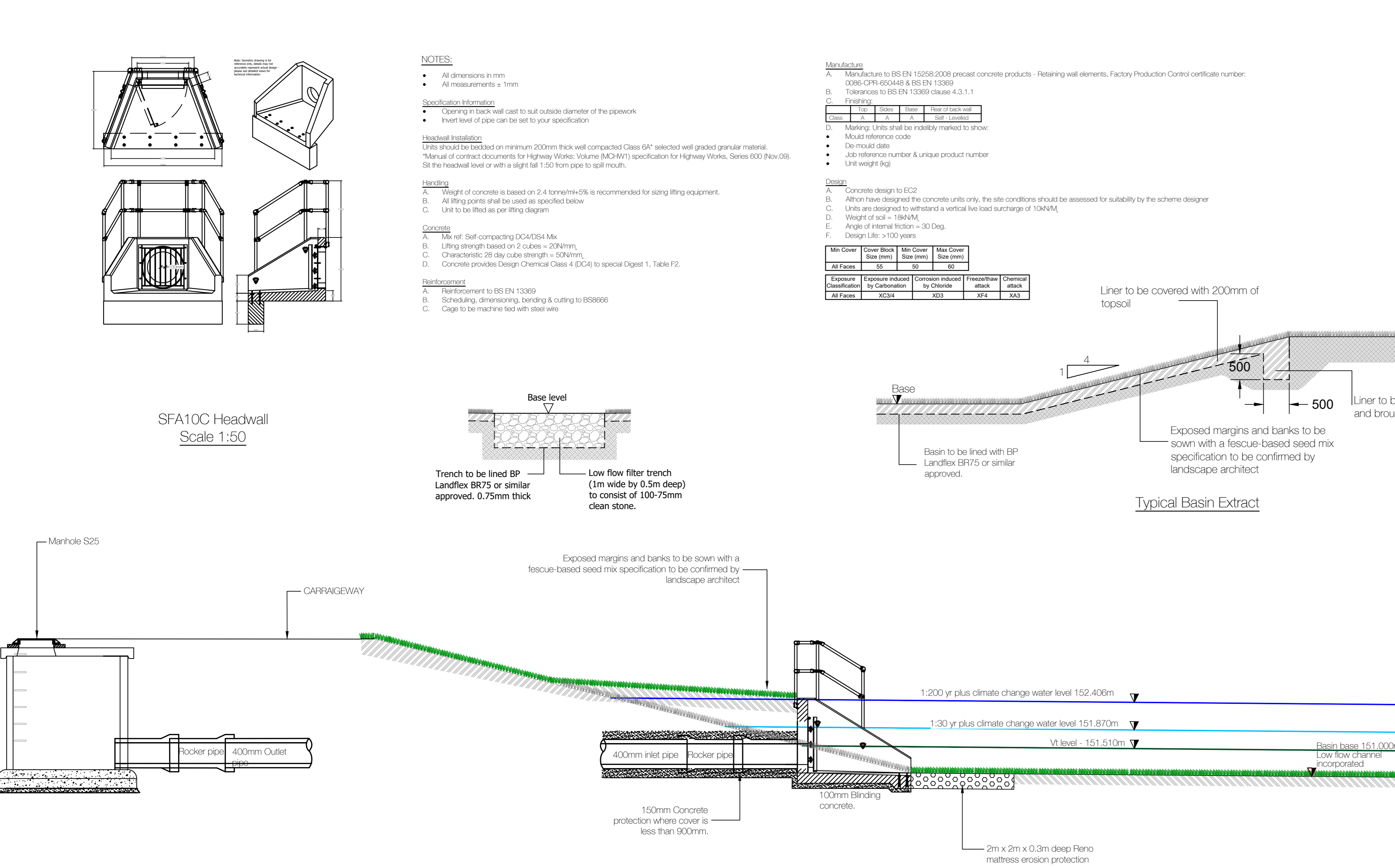
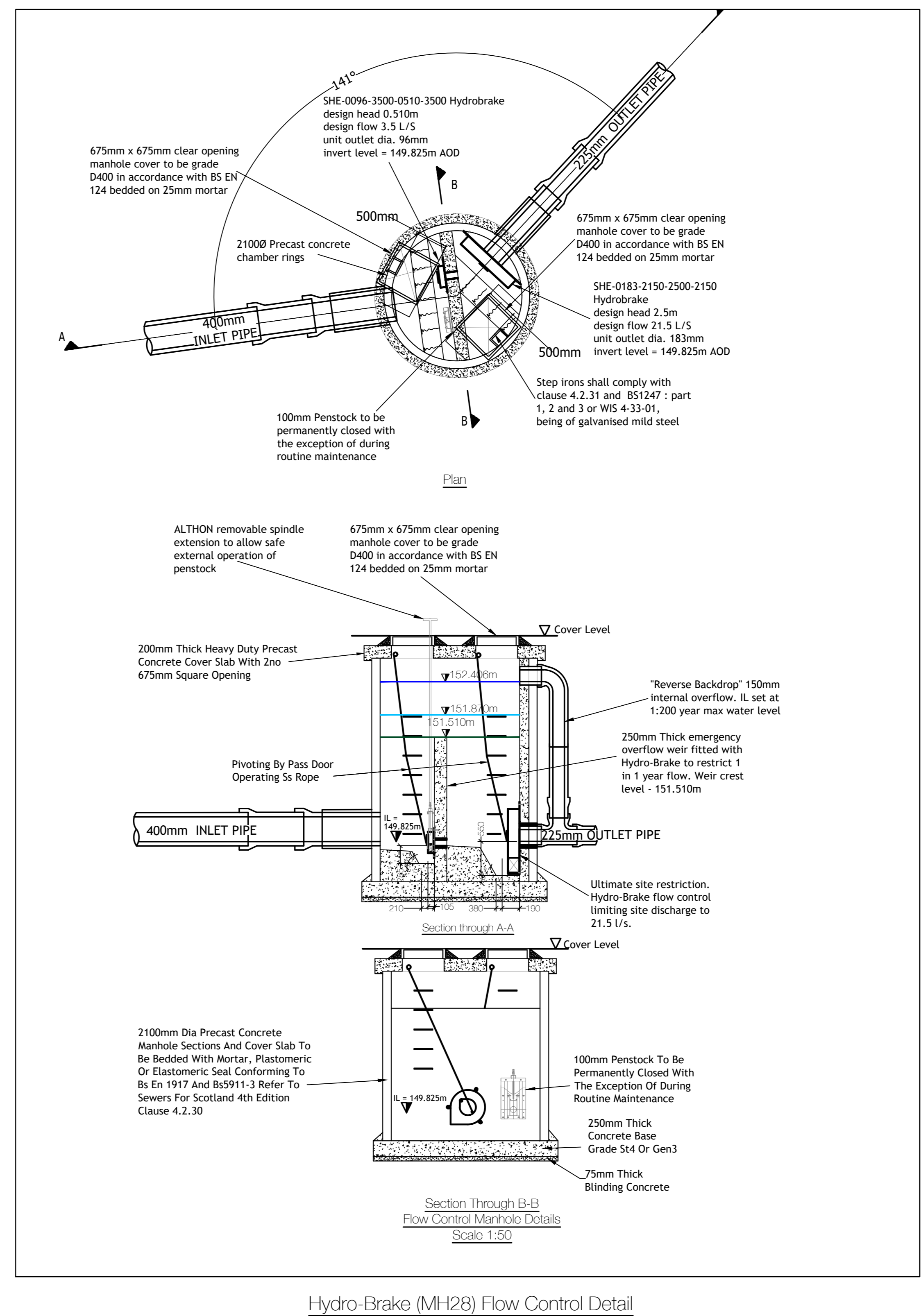
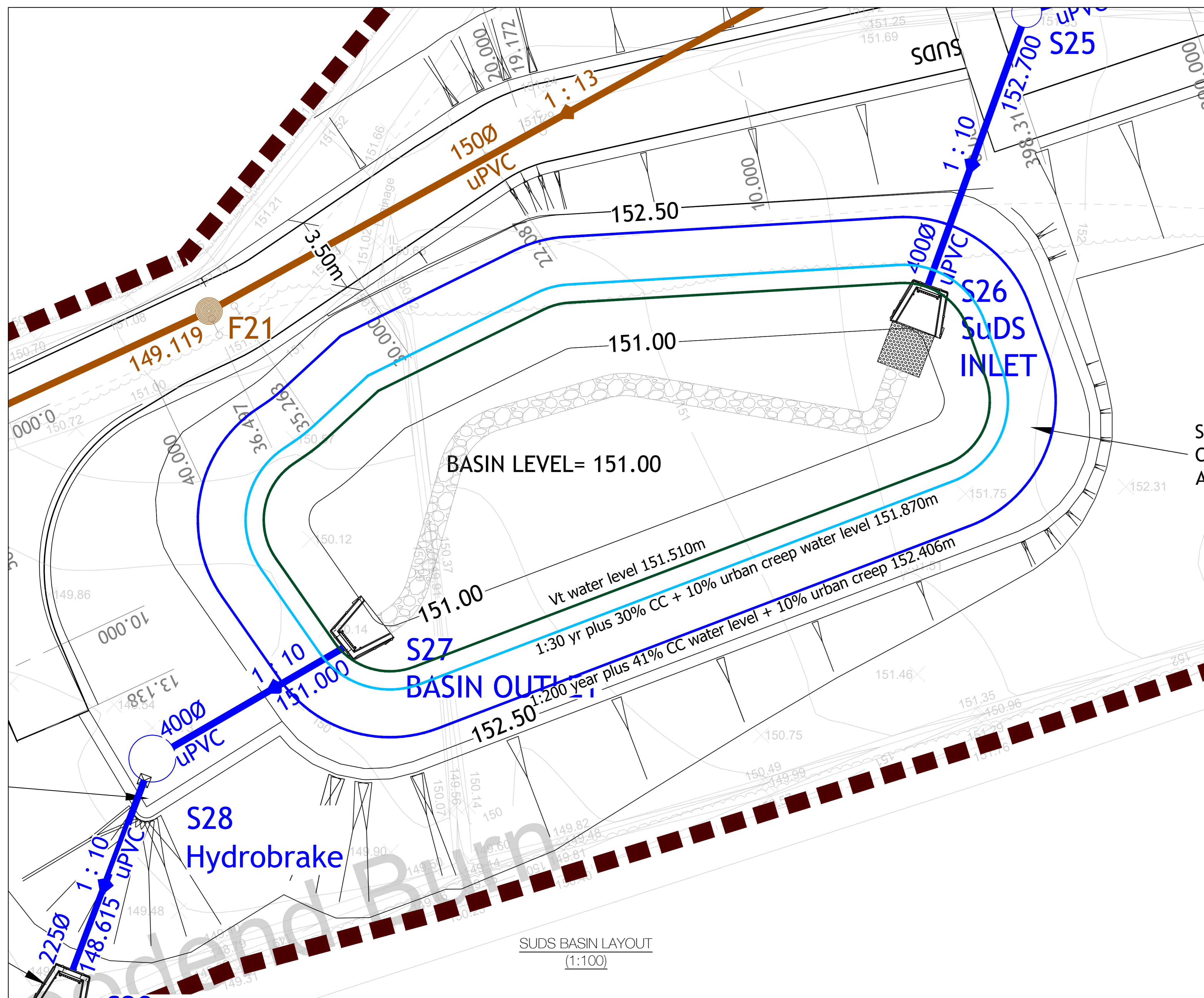

ALTHON PBA-G-100 HDPES Penstock Specification Information

- The penstock is supplied with a non-ripping spindle as standard
- It has an SCS grade bearing and an HPS back plate
- It has an HPS roofing plate provided with HPS ribs, different with HPS spindle back
- The roofing material and the spindle are made of S155
- The seal between the roofing and back plate consists of an integral EPDM to seal, which does not require any adjustment after installation

Material: HDPES, S2016, EPDM and HPS
 New Seal (Oval Profile): 1.5mm from bottom (invert level B.L.L.)
 Number of chemical anchors: 160 tops
 Number of chemical anchors: 160 tops
 New Seal: 1.5mm
 Control square socket removed when using grade extension

All dimensions in mm

THIS IS THE DRAWING REFERRED TO IN THE APPLICATION

DATE: 12.07.23

SIGNED: [Signature]

FOR DBA (AGENTS) ON BEHALF OF LGRR DESIGN & BUILD LTD

Client: LGRR DESIGN & BUILD LTD

Project: BELLEFIELD, LANARK

Drawing Title: SUDS DETAILS

Checked: S.McD. Date: 12.07.23

Checked: I.R. Date: 12.07.23

Scale: VARIES @A0

Proj No: 18243-500-106

App Status: APPROVAL

Color: COLOUR

Dougal Baillie Associates
 3 Glenfield Road, Kelvin
 East Kilbride, G75 5BA
 T: 01753 264400
 F: 01753 221991
 E: enquiries@dba.co.uk
 W: www.dougalbaillie.com