

LOFT PLAN

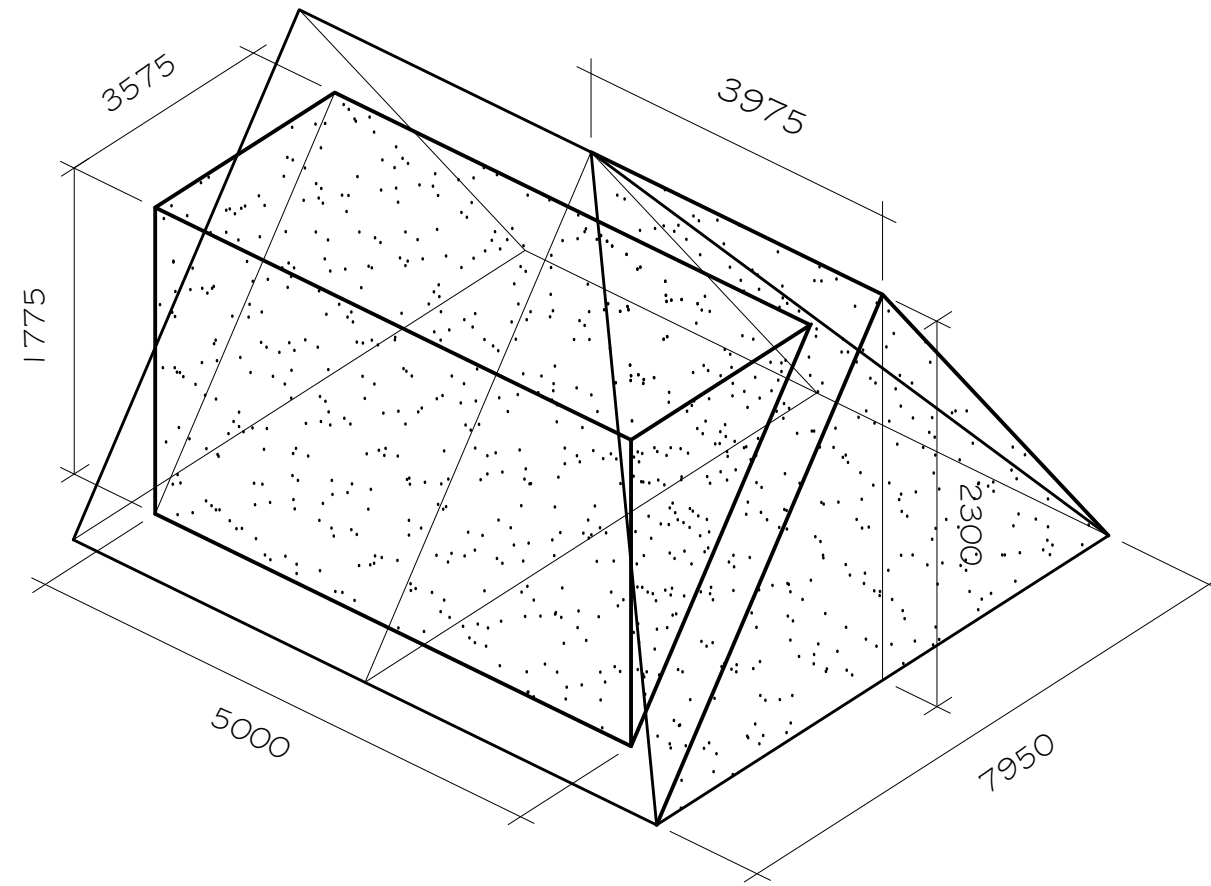

PROPOSED ROOF DORMER
 H : 1775mm
 W : 5000mm
 L : 3575mm
 VOLUME : 15.6 M3

PROPOSED HIP TO GABLE
 H : 2300mm
 W : 3975mm
 L : 7950mm
 VOLUME : 12.11 M3

TOTAL PROPOSED VOLUME:
 27.71 M3 < 40 M3

DIAGRAM ABOVE IS INDICATIVE -
 FOR ILLUSTRATION PURPOSES ONLY

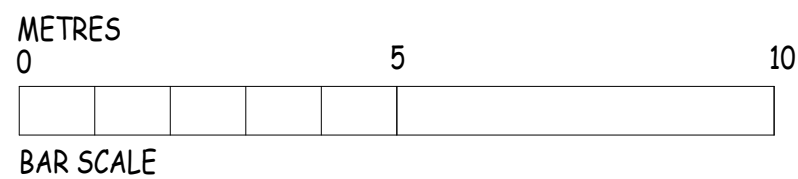

DISCLAIMER
 DOCUMENT IS COPYRIGHT AND MAY NOT BE REPRODUCED WITHOUT PERMISSION. REPRODUCTION IN WHOLE OR IN PART IS FORBIDDEN WITHOUT WRITTEN SANCTION OF ABSTRACT PLANS LTD. THIS DRAWING MUST BE READ IN CONJUNCTION WITH ALL OTHER DOCUMENTATION AND RELEVANT DRAWINGS.
 ABSTRACT PLANS LTD ACCEPTS NO LIABILITY FOR ANY EXPENSE, LOSS OR DAMAGE OF WHATSOEVER NATURE AND HOWEVER ARISING FROM ANY VARIATION WHICH HAS NOT BEEN REFERRED TO ABSTRACT PLANS LTD, AND THEIR APPROVAL OBTAINED.

PLANNING ONLY
 PLANNING CONDITIONS: It is the Clients responsibility Prior to commencement on site all relevant planning conditions to be discharged, including Tree Protection, Material Samples, Working hours etc. to your Councils Planning Dept

ABSTRACT PLANS
 STRUCTURAL • ARCHITECTURAL
 TEL: 01483 77 00 73
 Email: info@abstract-plans.co.uk
 Web: www.abstract-plans.co.uk

Project
 LOFT CONVERSION
 Address:
 41 STOCKERS LANE, WOKING, GU22 9DB
 Drawing Title
 PROPOSED LOFT PLANS & VOLUMES

Client THOMAS
 Drawing No. APL 1863 - P02
 Date MARCH 2024
 Drawn by APL
 Drg Size - A3 - 1:100