

NOTES:

1. For PSV, See SD01-013
2. Where necessary to match in with existing footway, concrete footway may be laid using the same construction as shown on SD 01-009 for 'All other crossovers'. Infill corners to be wed in block paved areas.
3. Manhole's to have grip top applied to match or similar.
4. Bedding and pointing may be substituted for proprietary specialist products as directed by Employers Representative.
5. Sub-Base depth to be increased, as required by the Employer's Representative, and geotextile membrane laid in poor ground conditions (CBR <2%).
6. Design of footways and cycleways to DMRB CD239.

**VEHICLE CROSSOVER TO PRIVATE DRIVES - FLEXIBLE CONSTRUCTION**  
(see BCC Standard Detail SD01-009)

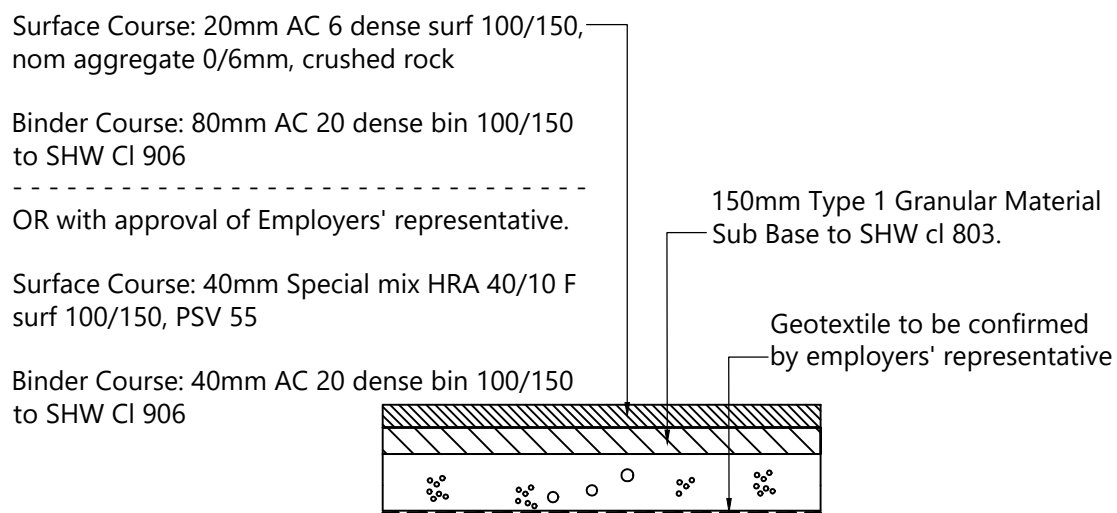

**TYPICAL EDGE DETAIL FOR CARRIAGEWAY**  
(see BCC Standard Detail SD01-010)

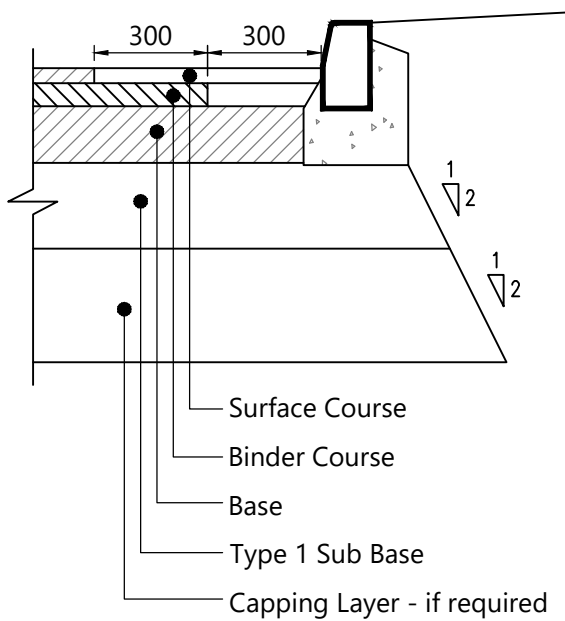

**TYPICAL TIE-IN DETAIL FOR FOOTWAY / VEHICLE CROSSOVER**  
(see BCC Standard Detail SD01-010)

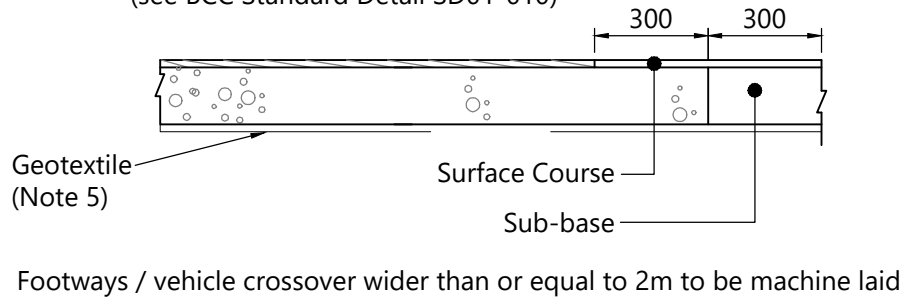

NOTES:

© Crown copyright and database rights 2024 OS Licence AC0000855217.

Based on 3bd Architects Proposed Site Plan ref. 588WR-PLA-101 and Lansdowne Surveys Ltd topographical survey for 130 Westbury Road, Bristol dated 9/1/23 Revision A.

Any road markings removed during construction to be reinstated.

ISSUE	REASON FOR REVISION	BY	DATE

PROJECT: <b>130 WESTBURY ROAD WESTBURY-ON-TRYM</b>		
CLIENT: <b>3bd ARCHITECTS</b>		
PROJECT REF: 22174	DRAWING NUMBER: 104	SCALE (AT A3): NTS
SHEET NUMBER: SHEET NUMBER 1 OF 1		
SCALE BAR:		
<b>HighgateTransportation</b> <small>www.highgatetransportation.co.uk          First Floor, 43-45 Park Street          Bristol BS1 5NL          01179 349 121          © Highgate Transportation Limited</small>		
TITLE: <b>PROPOSED MODIFIED ACCESS SURFACING DETAILS</b>		
DATE: 03.04.2024	DRAWN BY: BGS	CHECKED: FB