

NOTES:

1. ALL DIMENSIONS ARE IN MILLIMETERS UNLESS OTHERWISE NOTED
2. DO NOT SCALE FROM THIS DRAWING
3. ALL DIMENSIONS AND LEVELS ARE TO BE CONFIRMED
4. ALL DRAWINGS ARE TO BE READ IN CONJUNCTION WITH ALL OTHER RELEVANT DRAWINGS AND SPECIFICATIONS
5. ANY DISCREPANCIES BETWEEN ARCHITECTURAL, STRUCTURAL AND SERVICES DRAWINGS SHALL BE BROUGHT TO THE ENGINEERS NOTICE PRIOR TO EXECUTION OF ANY WORK ON SITE
6. THE CONTRACTOR SHALL BE RESPONSIBLE FOR PRODUCING A COMPLETE SET OF DETAILED, COORDINATED SHOP DRAWINGS FOR CONSULTANTS APPROVAL PRIOR TO EXECUTION OF ANY WORK ON SITE
7. THESE DRAWINGS ARE THE EXCLUSIVE PROPERTY OF NBBJ AND HAVE BEEN PREPARED FOR USE IN THE EXECUTION OF THE ENCLOSED PROJECT. USE OR REPRODUCTION FOR ANY OTHER PURPOSE WITHOUT THE WRITTEN PERMISSION OF NBBJ IS PROHIBITED.
8. DRAWINGS ARE INTENDED TO BE VIEWED ELECTRONICALLY OR TO BE PRINTED IN COLOUR.

ADDITIONAL NOTES: GIBSON LEVEL 3 AND ROOF HAVE BEEN MODELLED AND DRAWN ON ASSUMED INFORMATION

LEGEND:

- RETAINED
- DEMOLITION - WALLS
- DEMOLITION - AREA
- REMOVED AND REPLACED

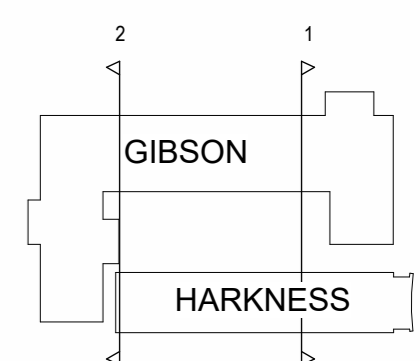

KEY PLAN

DRAWING ISSUE HISTORY:

ISSUE	DATE	DESCRIPTION
P03	28.03.2024	PLANNING ISSUE
P02	09.02.24	ISSUED FOR PLANNING AND STAGE 3
P01	15.12.23	ISSUED FOR LAYOUT FREEZE

DRAWING SUITABILITY CODE:
S4 - FOR STAGE APPROVAL

REVISION STATUS:
PRELIMINARY

PROJECT NAME:
Oxford Institute of Digital Health (OIDH)

PROJECT NUMBER: 103079.00 PROJECT STAGE: STAGE 3

DRAWN: SB CHECKED: DP APPROVED: TW
SCALE: As indicated@ A1 ISSUE DATE: 28.03.2024

DRAWING NAME:
DEMOLITION - SECTIONAL ELEVATION 2

DRAWING NUMBER: 598-NBBJ-ZZ-XX-DR-A-003011 ISSUE: P03



2 Demolition - Elevation - Courtyard - West
1 : 100

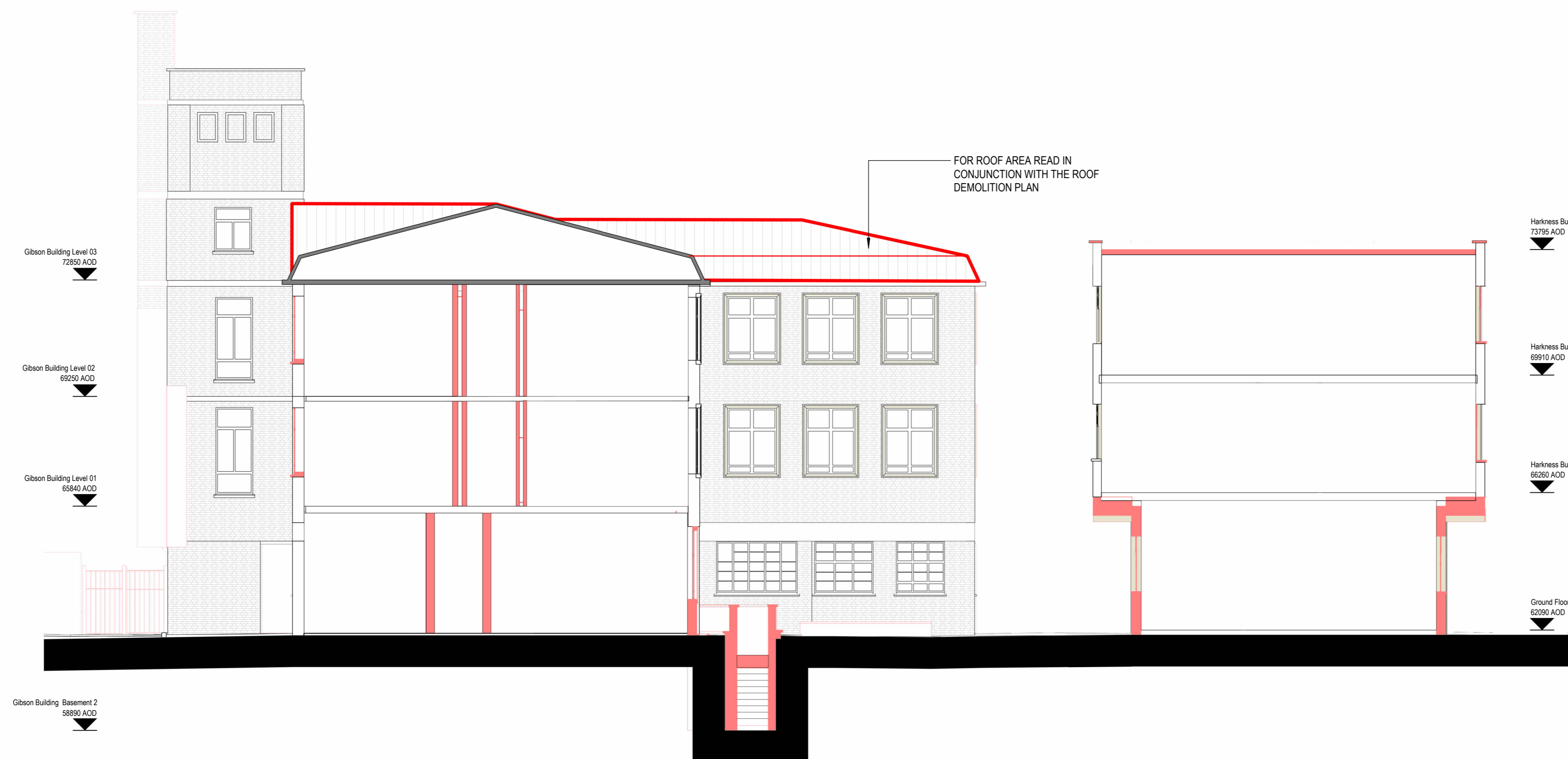

1 Demolition - Elevation - Courtyard - East
1 : 100

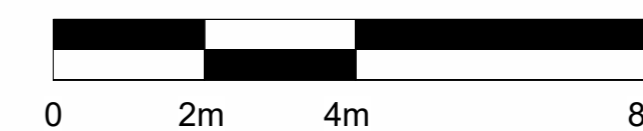

SCALE: 1:100