

# Liquistore<sup>®</sup>/Firestore<sup>®</sup>



**Ease and speed of assembly.** No sealants are used on the tank shell. This means that site installation can make full use of hydraulic jacking with the confidence in knowing that the integrity of the tank is not reliant on a large number of individual panel seals.

**Simplicity of foundations.** All that is required to site the tank is a flat load bearing surface, typically of reinforced concrete. The bottom rolled angle at the tank base is simply bolted to the concrete floor.

**Low maintenance.** Whether the high grade galvanised steel or marine alloy aluminium tank shell material is chosen, the result is a highly corrosion resistant exterior finish to the tank. Internally the tank shell is separated and therefore protected from the corrosive effects of the stored water, by the hot-vulcanised, tailor-made membrane liner. The internal liner will not rot or deteriorate in the same way as other coatings and finishes to the interior of tanks will.

Liquistore<sup>®</sup>/Firestore<sup>®</sup> tanks can be used for the storage of:

- Drinking water
- Fire protection/fire sprinkler water
- Process water
- Raw water

Using components that are assembled on site, consisting of overlapped and bolted panels of either a high grade galvanised steel, or a marine alloy of aluminium, together with an internal tailor-made waterproof liner, the Liquistore<sup>®</sup>/Firestore<sup>®</sup> tank offers a long-life, low maintenance water storage solution.

Standard tanks are available in a range of diameters and capacities to suit a wide range of applications. Covers are available in either a flat trough deck or pitched aluminium form and are also designed for assembly on site. Internal liners are available in a range of materials, to suit customers' requirements.

Liquistore<sup>®</sup> tanks are approved by the UK Water Research Advisory Scheme for the storage of drinking water.

Firestore<sup>®</sup> tanks are approved by the UK Loss Prevention Certification Board Factory Mutual Approvals for the storage of water for fire sprinkler systems.

# Liquistore®/Firestore® Technical Data

<b>Capacities</b>	From 10m <sup>3</sup> to 2,222m <sup>3</sup> in standard sizes. Larger capacities are available upon request. Maximum 1,300m <sup>3</sup> for UK LPC approval.
<b>Dimensions</b>	From 3.06m to 21.39m in diameter, maximum height is dependent upon diameter. At 21.39m diameter maximum height is 6.33m. Larger diameters available upon request.
<b>Ancillaries/Accessories</b>	A wide range of extra equipment and fittings are available, including: Ball float valves, high/low level switches, internal ladders, sump liners, fire brigade couplings, low level manways. Standard accessories include: Immersion heater, anti-vortex device, contents gauge, external ladder and landing, WRc Type 'AB' airgap.
<b>Foundations</b>	All that is required is a flat load bearing slab. A suggested layout for each of our standard tank dimensions is available on request. Foundation loading is based upon the rim height of the tank multiplied by 9.81 + kN/m <sup>2</sup> . Level tolerance should be +/- 6.0mm across base.
<b>Design</b>	Liquistore/Firestore tanks are designed to withstand normal UK conditions including moderate wind loads, when fully complete and filled. Designs to meet non-standard requirements, such as severe wind loads and potential seismic conditions are available on request.

Typical 135m<sup>3</sup> Firestore® Fire Sprinkler water storage tank. 6.11m diameter x 5.142m high.

Elevation

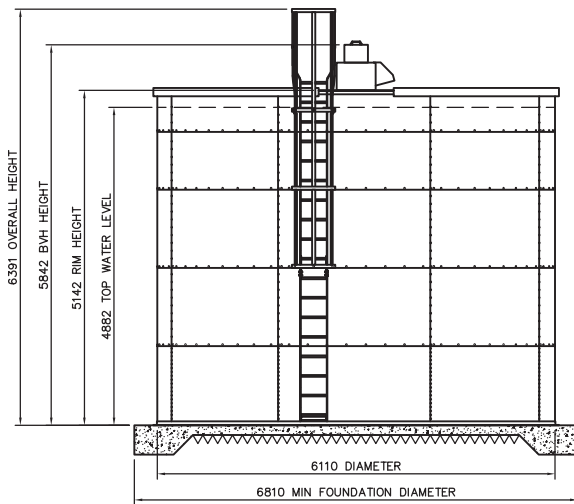

Plan

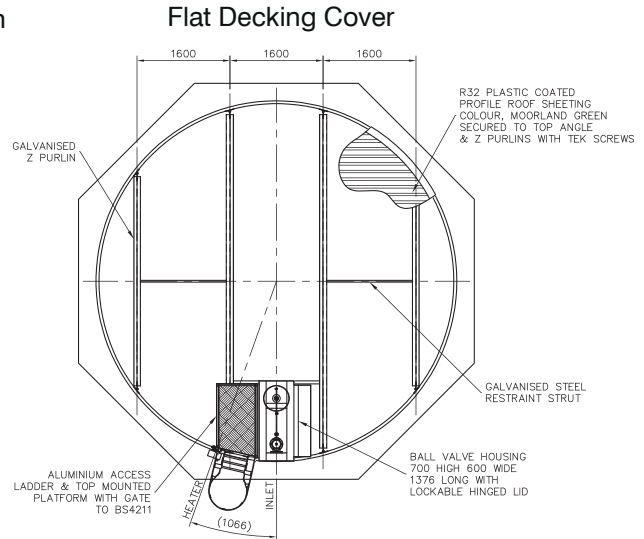

Pitched Aluminium Cover

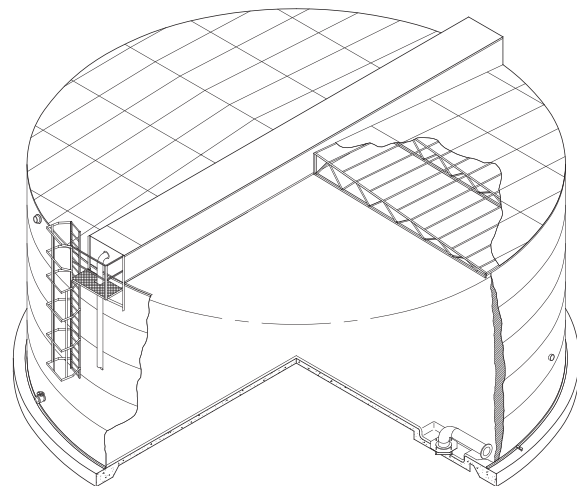

Typical connection through tank wall

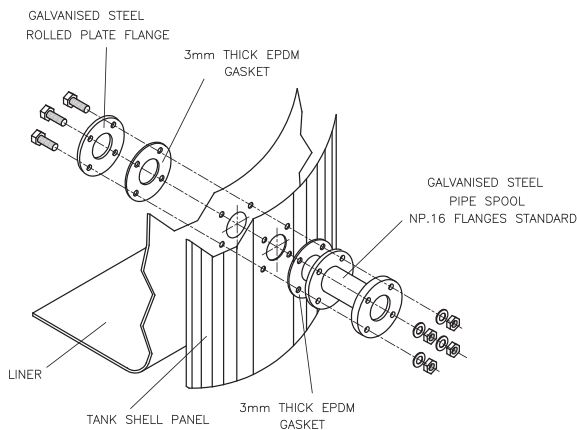

**Franklin Hodge Industries Ltd**  
 Jubilee Building, Westfields Trading Estate  
 Faraday Road, Hereford HR4 9NS  
 Telephone: +44 (0) 1432 269605  
 Fax: +44 (0) 1432 277454  
 Web: [www.franklinhodge.com](http://www.franklinhodge.com)