

**SITE MANAGER - ENSURE NO OPERATIONS WITHIN RPA WITHOUT CONSULTATION WITH PROJECT ARBORICULTURAL CONSULTANT (INCLUDES ECOLOGICAL MEASURES SUCH AS REPTILE FENCING)**



**TREE PROTECTION AREA  
KEEP OUT!**

TREES ENCLOSED BY THIS FENCE ARE PROTECTED BY PLANNING CONDITIONS AND/OR ARE THE SUBJECT OF A TREE PRESERVATION ORDER. CONTRAVENTION OF A TREE PRESERVATION ORDER, MAY LEAD TO CRIMINAL PROSECUTION. THIS FENCING MUST NOT BE REMOVED WITHOUT PERMISSION FROM THE TREE AND LANDSCAPE OFFICER

**ATTENTION!**

**TREE PROTECTION**

Tree protection comprises two elements;

1. Fencing AND;
2. ground protection

Do not assume that because you are outside the fence you are outside the RPA.

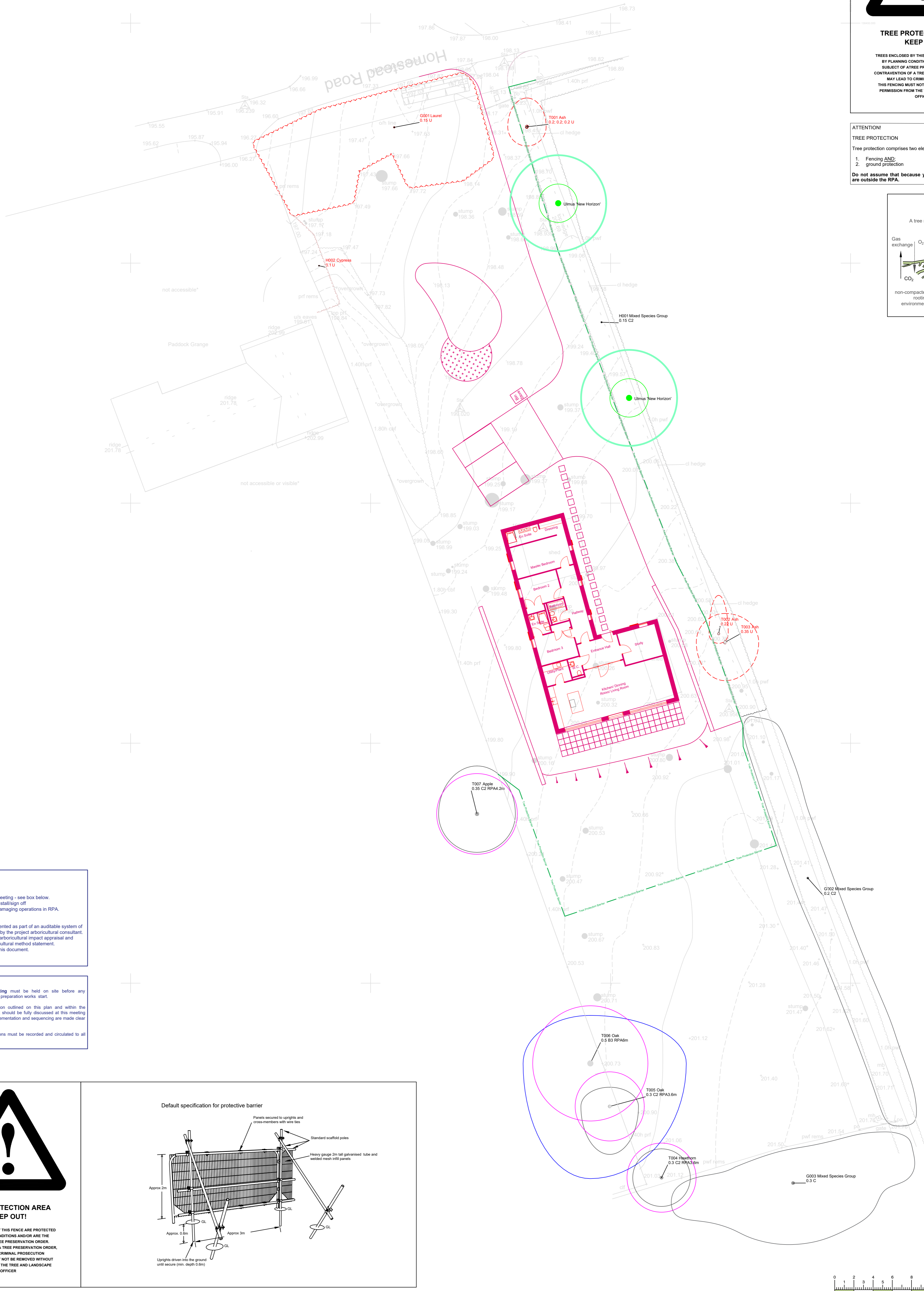
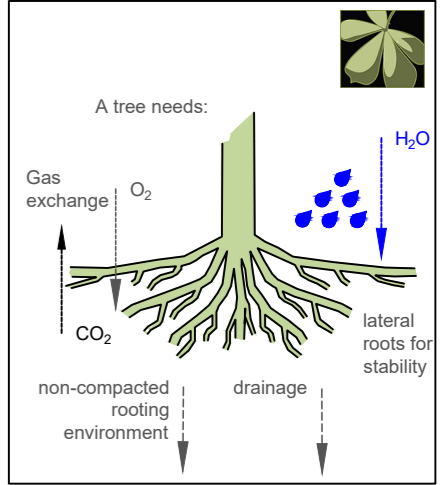

**TREE PROTECTION PLAN**

**Arboricultural supervision**  
Minimum expectations:  
1. pre-commencement meeting - see box below.  
2. protective measures installed/sign off  
3. any other potentially damaging operations in RPA.  
The above should be documented as part of an auditable system of arboricultural site monitoring by the project arboricultural consultant. Refer to relevant sections of arboricultural impact appraisal and operation guidance in arboricultural method statement. If in doubt contact author of this document.

**Important note**  
A pre-commencement meeting must be held on site before any development, demolition or site preparation works start.  
The methods of tree protection outlined on this plan and within the associated arboricultural report should be fully discussed at this meeting so that all aspects of their implementation and sequencing are made clear to all parties.  
Any clarifications or modifications must be recorded and circulated to all parties in writing.

**TREE PROTECTION AREA  
KEEP OUT!**

TREES ENCLOSED BY THIS FENCE ARE PROTECTED BY PLANNING CONDITIONS AND/OR ARE THE SUBJECT OF A TREE PRESERVATION ORDER. CONTRAVENTION OF A TREE PRESERVATION ORDER, MAY LEAD TO CRIMINAL PROSECUTION. THIS FENCING MUST NOT BE REMOVED WITHOUT PERMISSION FROM THE TREE AND LANDSCAPE OFFICER

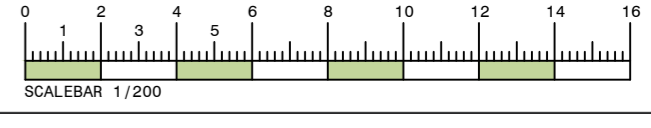
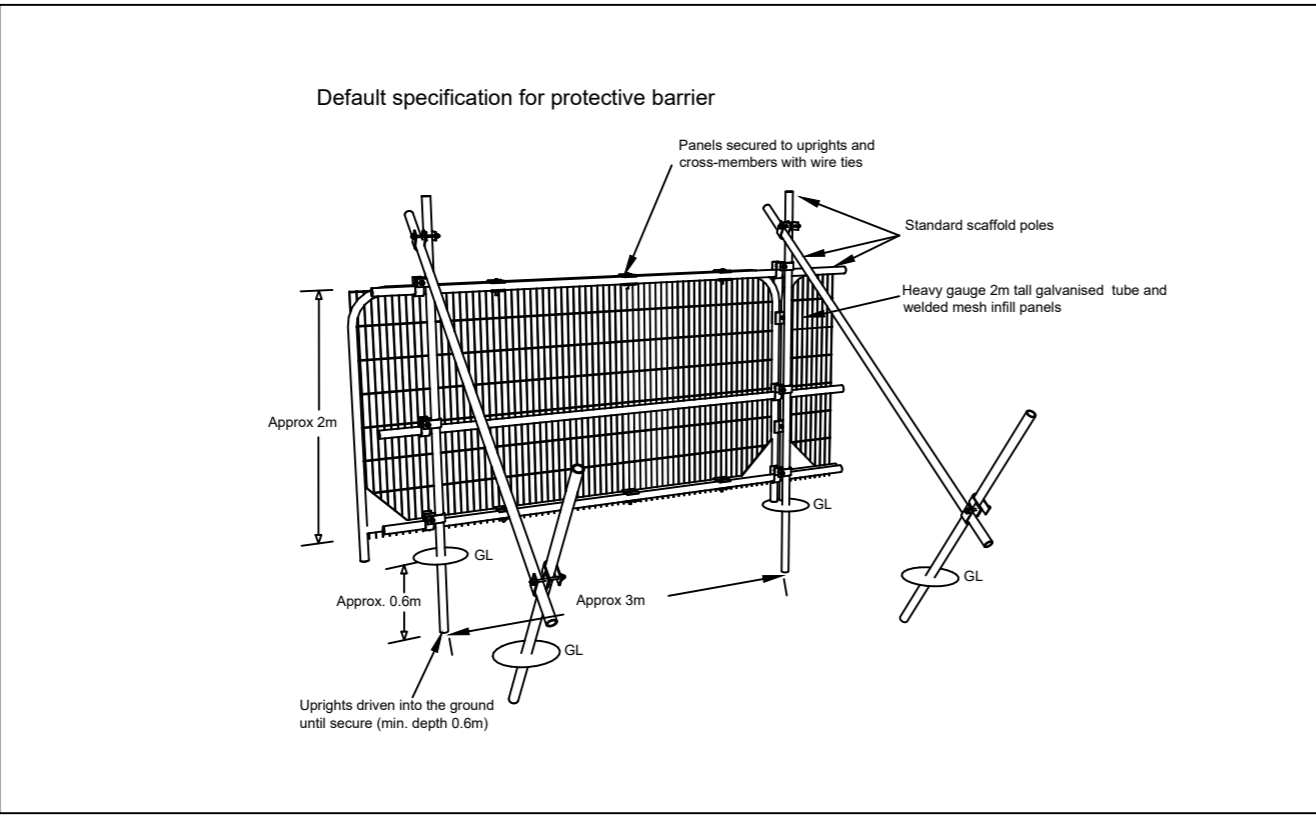

**Legend**

- Tree number
- Common name
- Tag number (where tags used)
- Root protection area (RPA) for retained trees
- Indicative crown spread based on measurements at cardinal points (N,S,E,W). Trees for removal shown with dotted red canopy line
- Stem diameter in metres
- Stem collar shown at stem diameter
- British Standard category in words
- root protection area (RPA) radius in metres (retained trees only)
- British Standard category as colour coded circle and crown spread (retained trees only)
- Indicative location and suggested species of new semi mature tree. Crown spread shown as estimated after 25 years (thin circle)(data from Hillier's design guide) and ultimate crown spread (thicker circle)(data from Gruffydd - Tree Form, Size and Colour). Species selection guided by the above and Tree Species Selection for Green Infrastructure (Hirons and Spoman, 2016)

- Proposed new development.
- Tree Protection barrier - Protective fencing to BS5837:2012. Refer to BS5837 figure 2 and figure 3 as appropriate.

**Technical Arboriculture**  
www.techarb.co.uk

**PROJECT** Land adj, Paddock Grange, Medstead  
**DATE** December 2023  
**JOB REF** AA/AMS-KC/PADDOCKGRANGE/001  
**DRAWING NO** TTP-KC/PADDOCKGRANGE/001  
**DRAWN** KC  
**SCALE** 1:200 at A1  
**STATUS** FINAL  
**REVISION** 0

**REVISION NOTES**