

Roof Plan

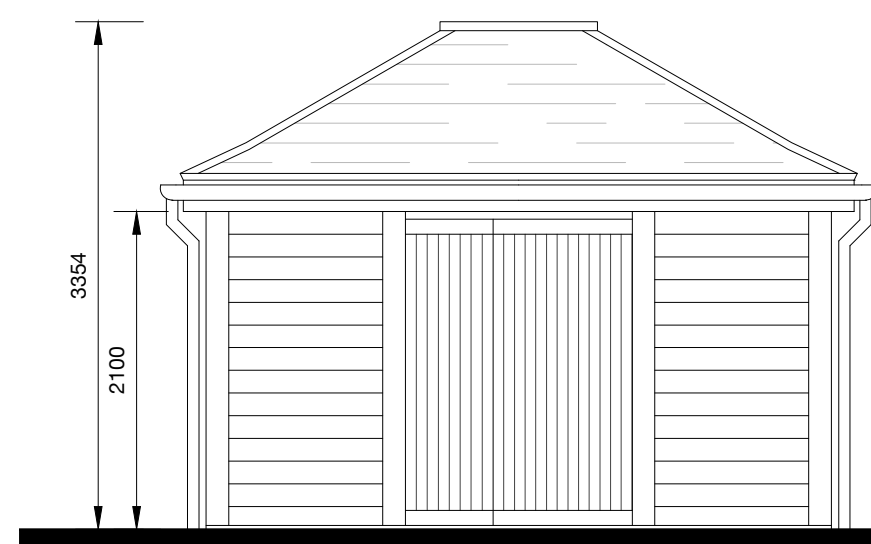

Front Elevation
(West)



Side Elevation
(North)

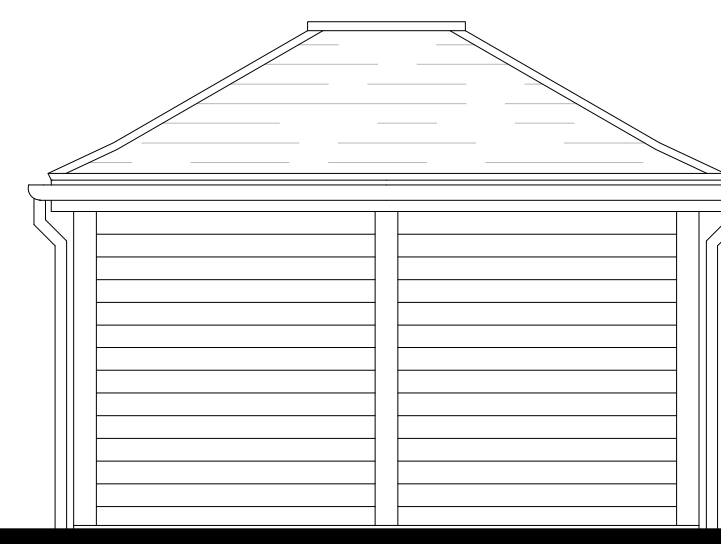

Rear Elevation
(East)

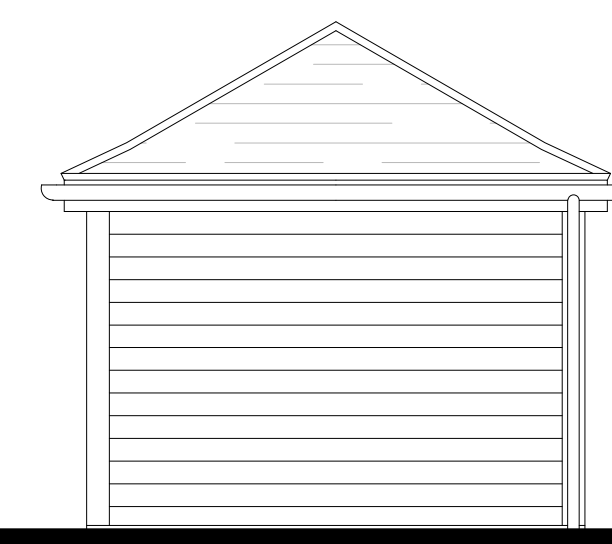

Side Elevation
(South)

Bin Store

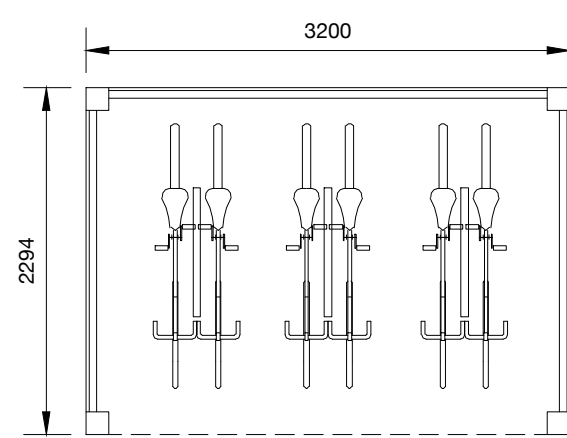

Floor Plan

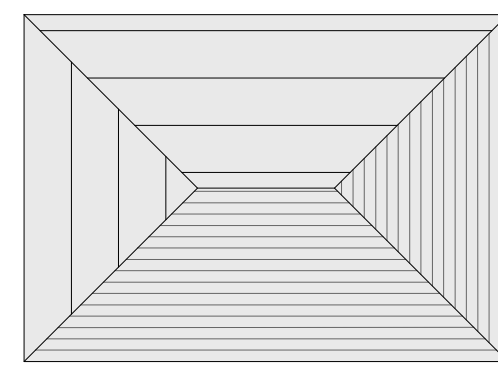

Roof Plan

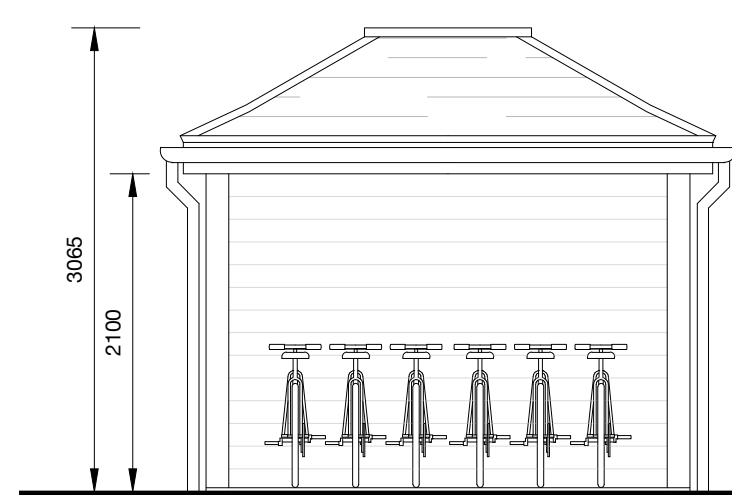

Front Elevation
(North)



Side Elevation
(East)

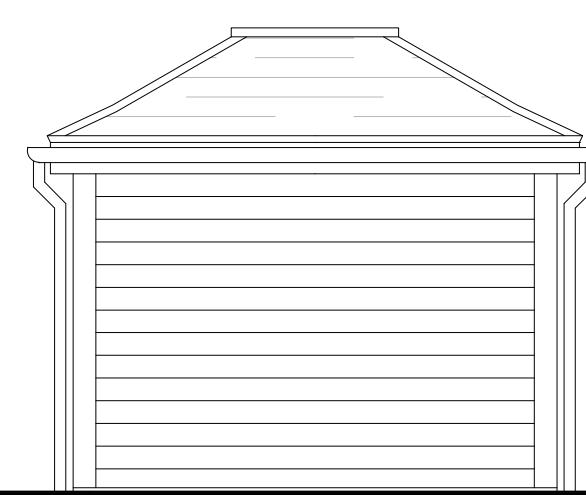

Rear Elevation
(South)

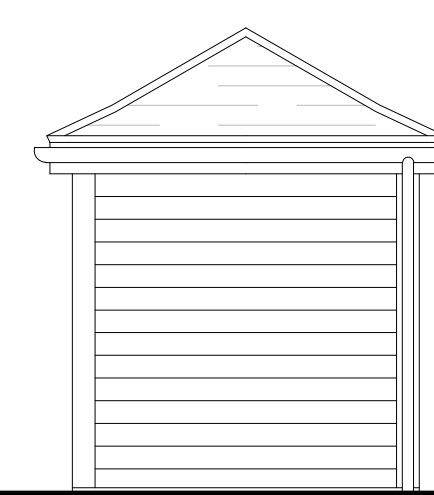

Side Elevation
(West)

Cycle Store

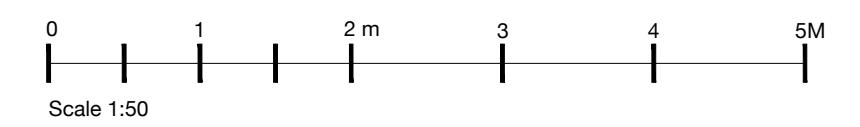

Rev.	Date	Detail
Status: Planning Issue		

HALO
 ARCHITECTS

Halo Architects Ltd.
 The Old Fire Station, Pyncroft Road, Chertsey KT16 9HL
 Tel: 01344 692453 Email: enquiries@haloarchitects.co.uk
 www.haloarchitects.co.uk

Client: **Hestia Homes Ltd**

Project Title:
**3 Lavant Road
 Chichester
 PO19 5QY**

Drawing Title: **Bins & Cycle Store Details**

Scale	Date	Drawn
1:50@A1	03.2024	KF

Job No.	Drawing No.	Rev.
HA24-276	P009	-