

01 Master bedroom window jamb detail
1:10 @ A3

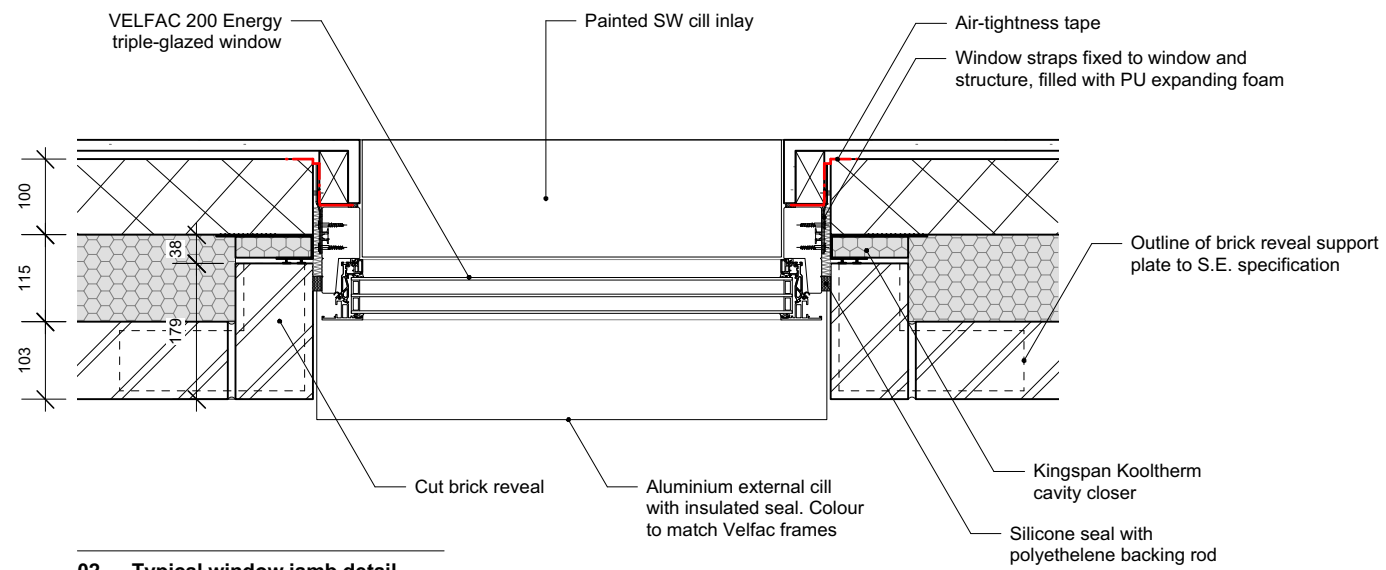

02 Typical window jamb detail
1:10 @ A3

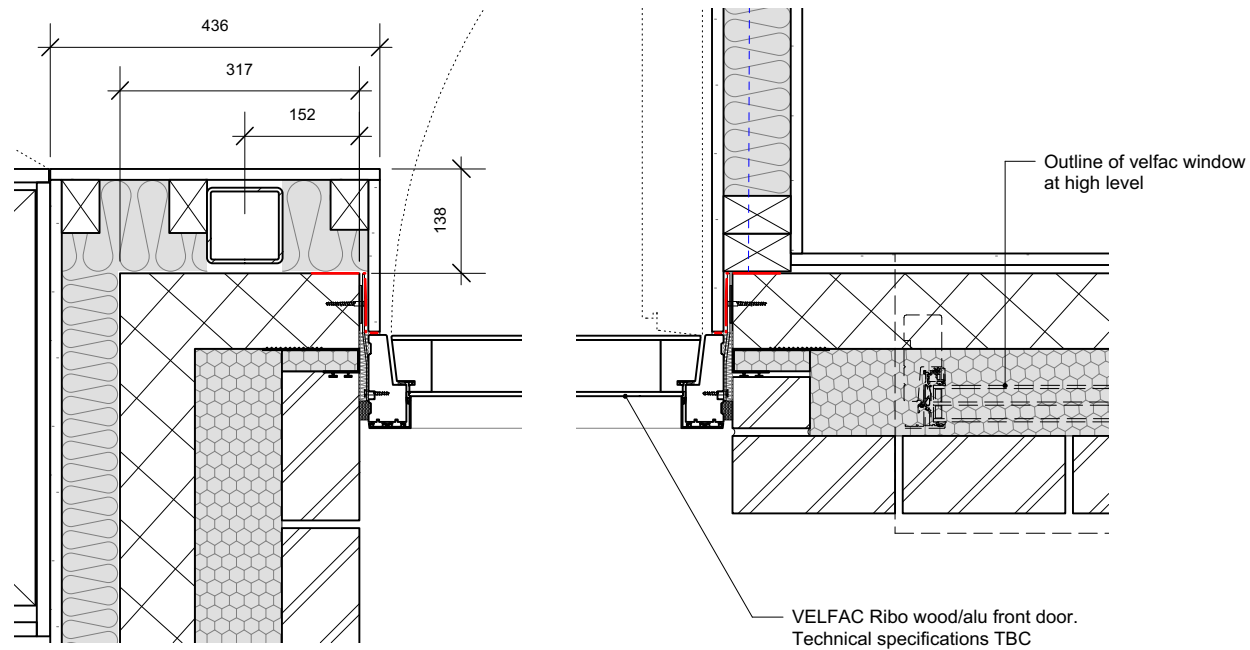

03 Front door jamb detail
1:10 @ A3

General Notes
DO NOT SCALE. All dimensions must be checked on site, errors are to be reported.
All illustrated material is subject to copyright. Unless otherwise agreed in writing, all rights to use this document are subject to payment of all Architect's charges. This document may only be used for the express purpose and project for which it has been created and delivered, as notified in writing by the Architect. This document may not be otherwise used or copied. Any unauthorised use of this document is at the user's sole risk and without limiting the Architect's rights the user releases and indemnifies the Architect from and against all loss so arising.

Safety Note
CDM 2015
It is considered that there are no other risks that would not be recognised by a competent contractor familiar with this type of work.

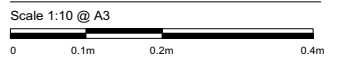

Issue Record **Chk** **Date**

1 First issue AG 20/03/24

Title
Window/door plan details

Project
80 St Andrews Road, Bristol

Scale
1:5 @ A1 1:10 @ A3

Status
TENDER Drawn by BP

Drawing Number
111-P-4-064 Revision 01

GAMBLES ARCHITECTS

Studio D, 25-27 Stokes Croft
Bristol, BS1 3PY
T: 0117 2800128 / 07974 262927
www.gamblesarchitects.co.uk