

Front Elevation



Rear Elevation

Flat 2/2, 4 Park Terrace
Glasgow G3 6BY

Current state of windows

– description of application

The Property is A listed terraced townhouse at 4 Part Terrace and overlooks Kelvingrove park. Top floor windows at front elevation are very exposed to rain and high winds from prevalent southwesterly direction. Windows at front elevation are not original-possibly replaced when property was developed in 2005. There has been an issue with front windows since current owners purchased property. Issues with water ingress under panes in high winds. Also, wet rot in frames and sills have been repeatedly repaired, filled and painted, but rot in one frame now beyond small repair. Rear windows have had some issues with rot that have been repaired, particularly in sills. All windows are single glazed and fail to meet energy efficiency requirements of todays standards. In order to remove rot issues and to improve energy efficiency band of the property the owners wish to have newly manufactured double-glazing windows installed by Sashseal windows Ltd. The sash-case windows will be like for like to existing windows. Thus, the character of the building will remain the same, plus the property will be more energy efficient which is the best compromise between meeting the city councils aim of retaining the character of listed properties and meeting the Scottish governments aim of having more energy efficient domestic dwellings. Two other flats in the building have recently had the windows replaced by Sashseal windows using same window design and materials, planning application 23/02161/FUL and 23/02160/LBA.



**Rot
repair**

Front Elevation Inside: W01

Ref: D



Ref: A

Ref: C

Ref: B

PROJECT

Flat 2/2, 4 Park Terrace
Glasgow G3 6BY

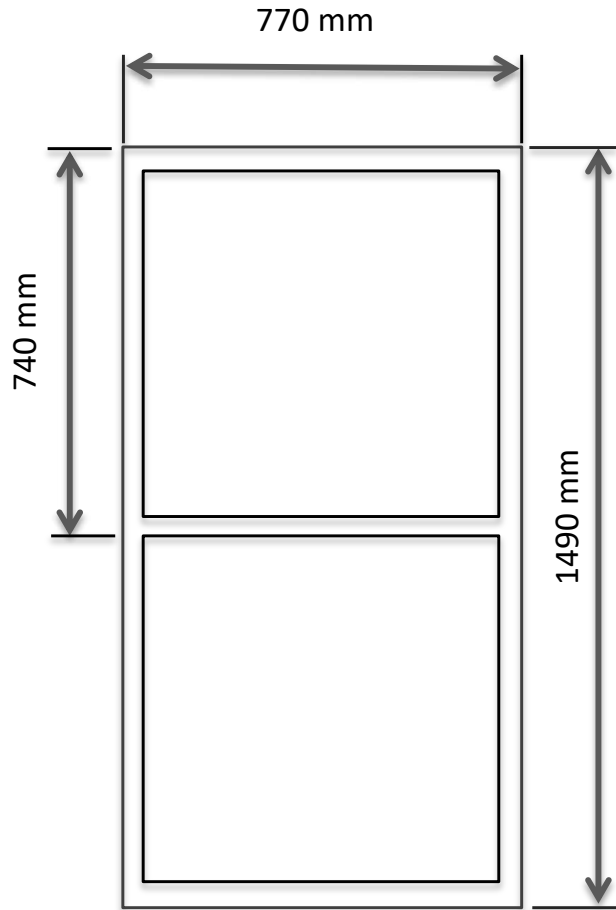

Reference: A

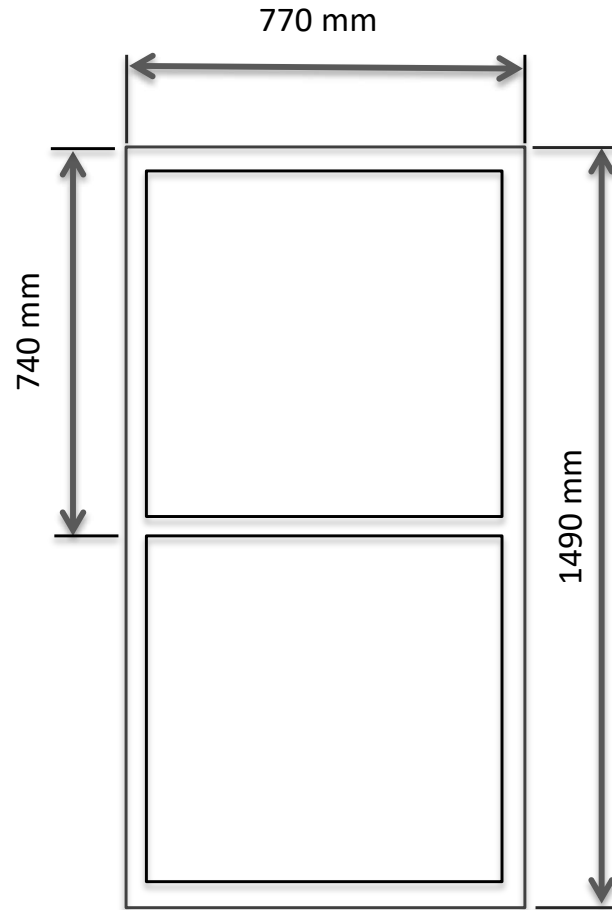

Reference: B

Exterior windows will be painted to match existing finish

All windows will be fitted with a 4/12/4 low E gas filled unit to achieve a 'U' value of 1.4

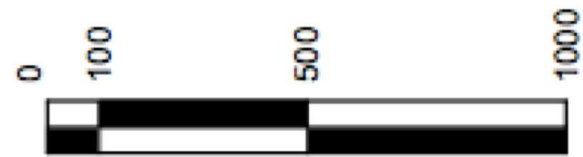

scale 1:20 @ A3

Windows will be manufactured in Traditional ropes & weights, NOT spiral balances

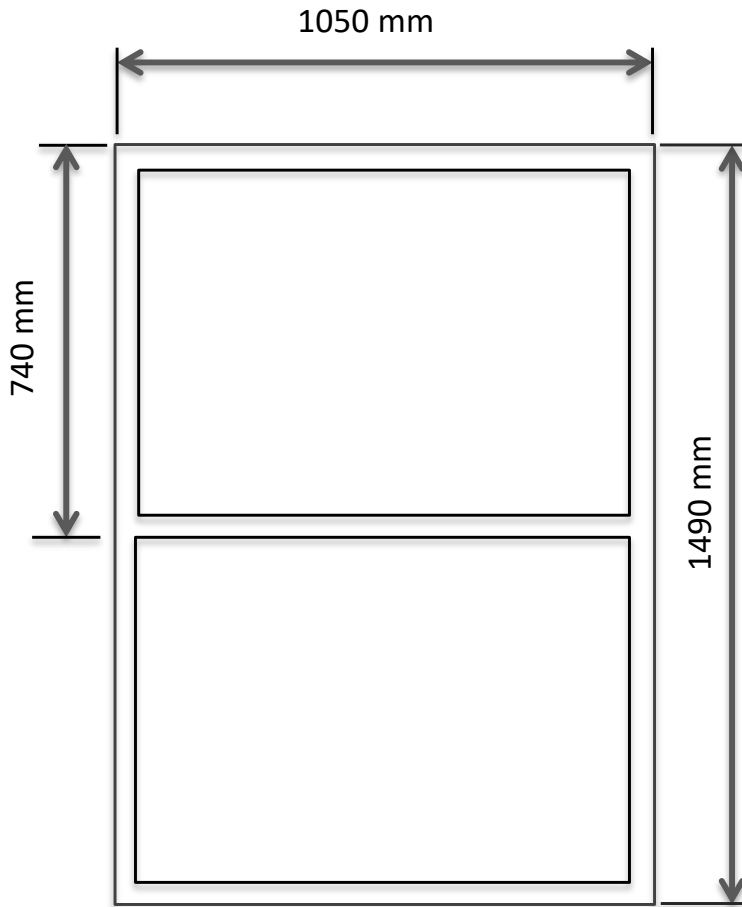

Reference: C

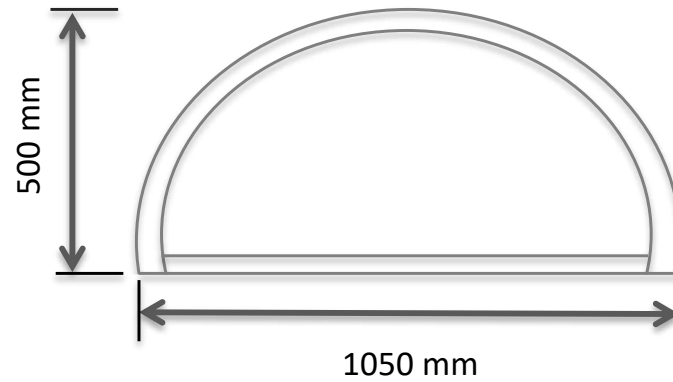

Reference: D

Exterior windows will be painted to match existing finish

All windows will be fitted with a 4/12/4 low E gas filled unit to achieve a 'U' value of 1.4

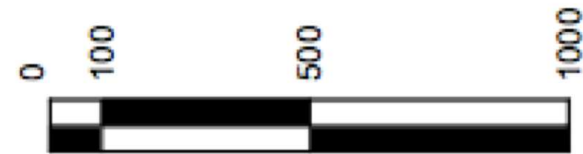

scale 1:20 @ A3

Windows will be manufactured in Traditional ropes & weights, NOT spiral balances

PROJECT
Flat 2/2, 4 Park Terrace
Glasgow G3 6BY

Front
Elevation
Continued

Rear Elevation Inside



W02

Rear master bedroom window



W03

Rear 2nd bedroom window

PROJECT
Flat 2/2, 4 Park Terrace
Glasgow G3 6BY

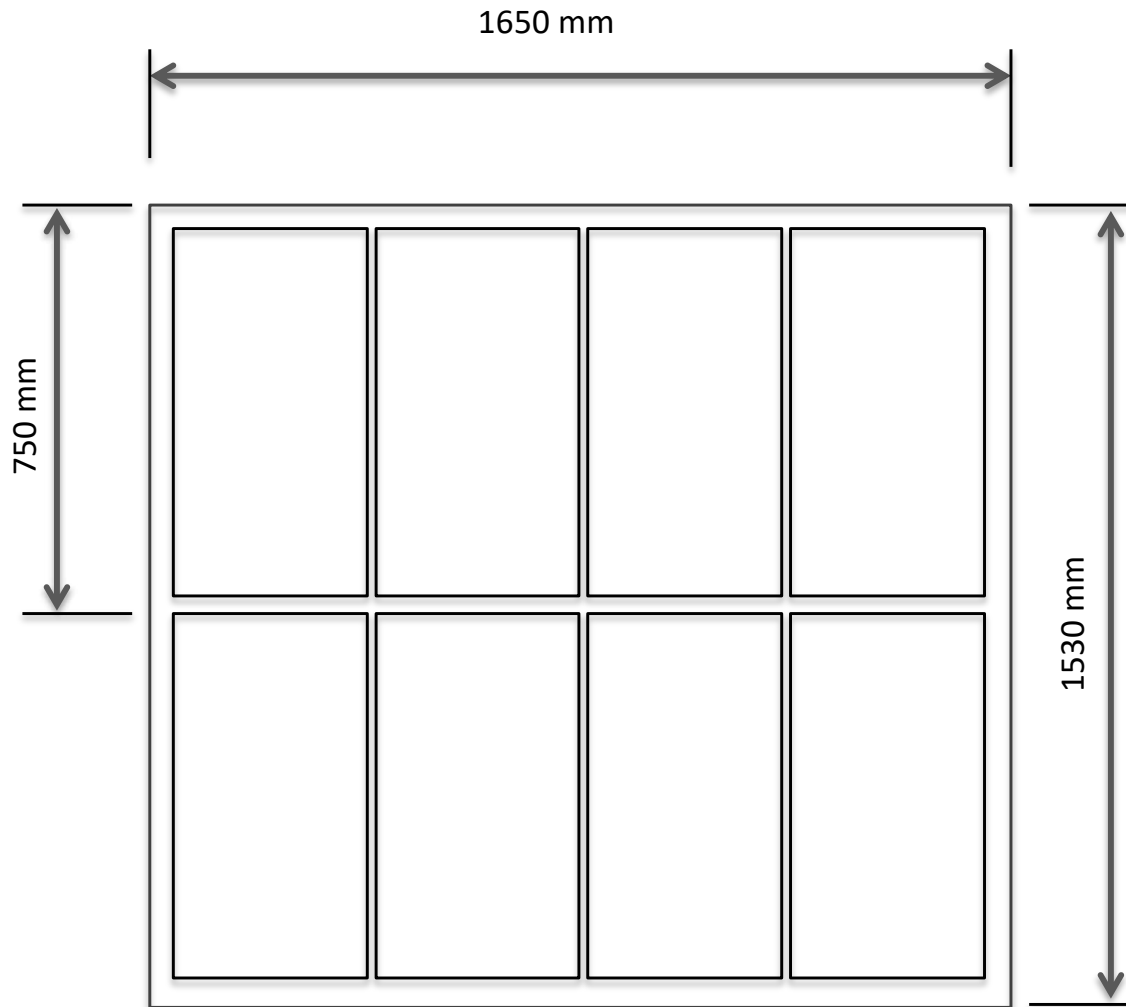

W02

Exterior windows will be painted to match existing finish

All windows will be fitted with a 4/12/4 low E gas filled unit to achieve a 'U' value of 1.4

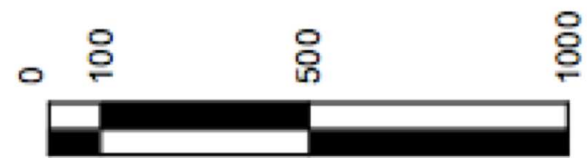

scale 1:20 @ A3

Windows will be manufactured in Traditional ropes & weights, NOT spiral balances

PROJECT
Flat 2/2, 4 Park Terrace
Glasgow G3 6BY

**Rear
Elevation**

A.03

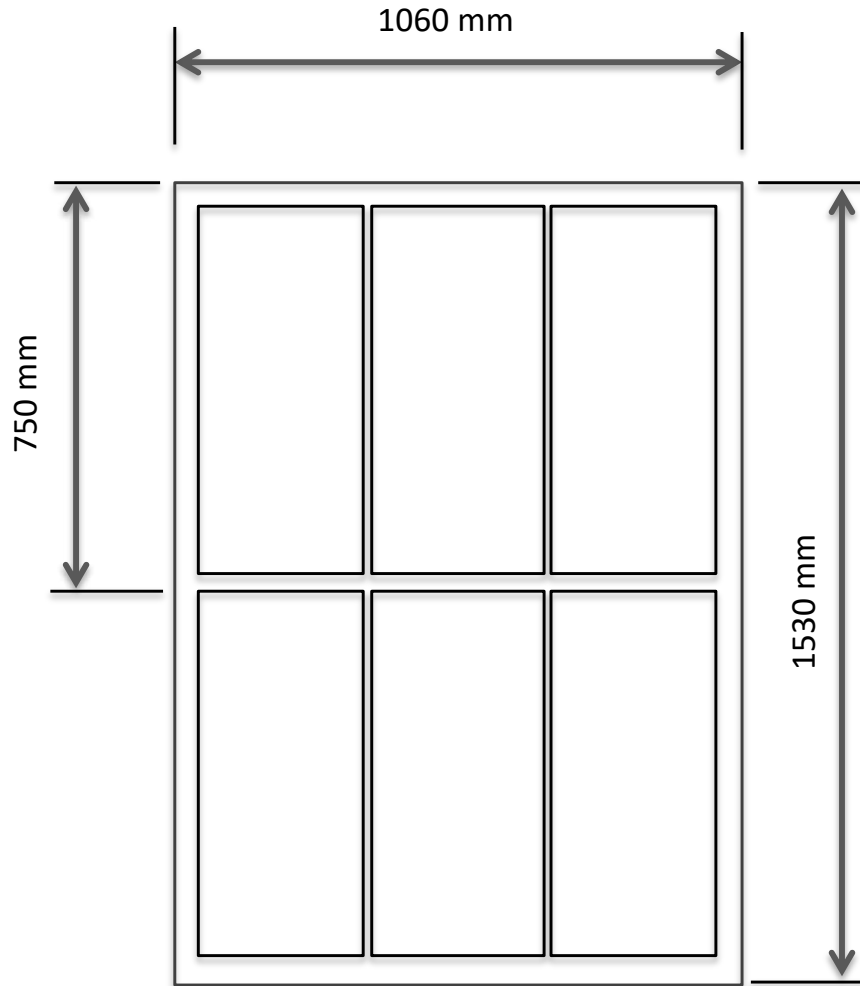

W03

Exterior windows will be painted to match existing finish

All windows will be fitted with a 4/12/4 low E gas filled unit to achieve a 'U' value of 1.4

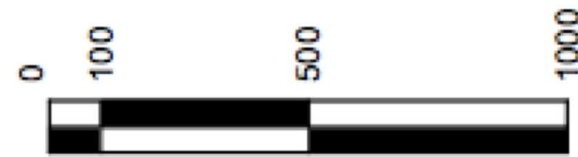

scale 1:20 @ A3

Windows will be manufactured in Traditional ropes & weights, NOT spiral balances

Description of windows – Flat 2/2, 4 Park Terrace

All windows manufactured by Sashseal windows Ltd are made from a Majou hardwood to the specifications and guidelines within BSEN942: general classification of timber quality

The glass to be installed (due to size restriction) will be Slimlite heritage Range and standard double glazed units. 4mm Super Low 'E'/12mm

Super Spacer – gas filled/4 mm clear. This will create a 20 mm unit and a 'U' value of 1.4w/m²K.

The glazing units will be bedded in to sashes using a Silfix U9 Sealant then another bed applied to the front edge of the glass. Once set a putty line will be applied using linseed multi-purpose putty. The Silfix sealant is required to protect the bitumen from breaking down against the putty. This process allows creation of a window with a traditional putty line and remains in keeping with the original single glazed windows.

All window exteriors will be painted with 3 coats of Sherwin Williams Laqvin prime and finished with Laqvin Top. The interiors will be coloured/stained to match existing finish.

All windows will have the concealed draught proofing system installed

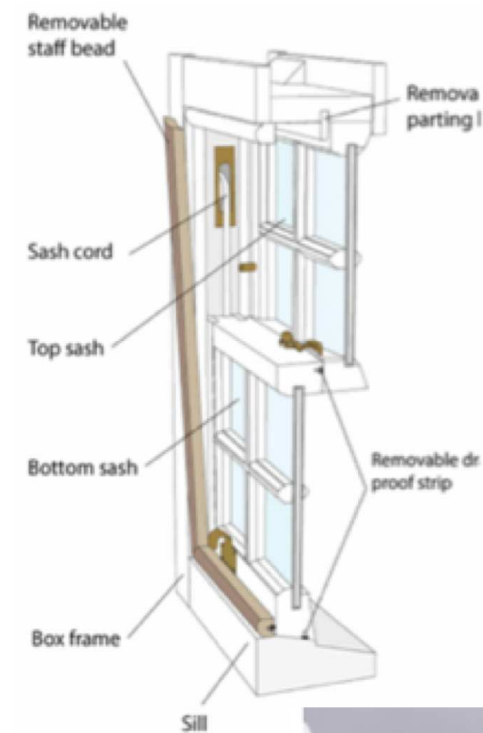

Description of windows

Weights are attached using sash cord, fixed on to the sash via a pulley wheel.

After the sashes are glazed they are weighed and then steel counter balances are cut to size in keeping with the traditional counter balanced sash and case window design.



Window-Components

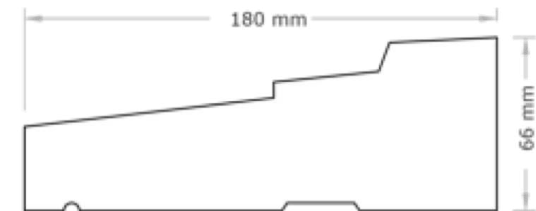
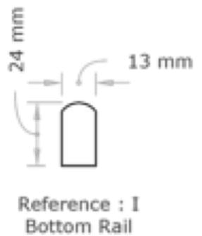
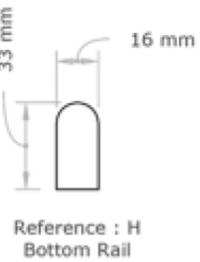
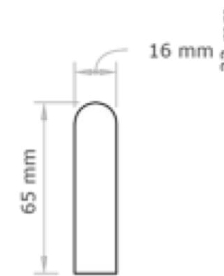
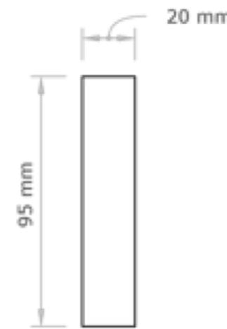
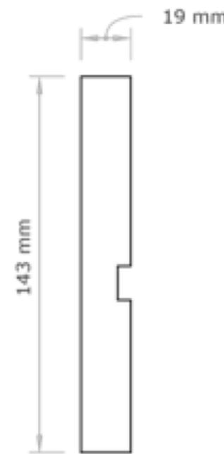
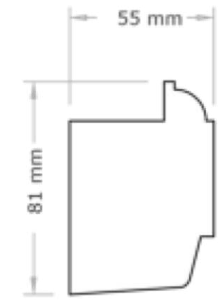
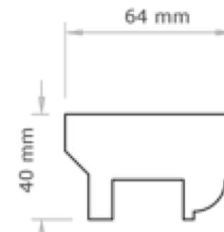
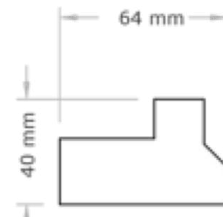
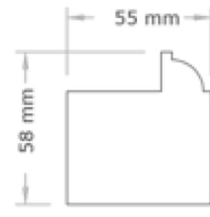
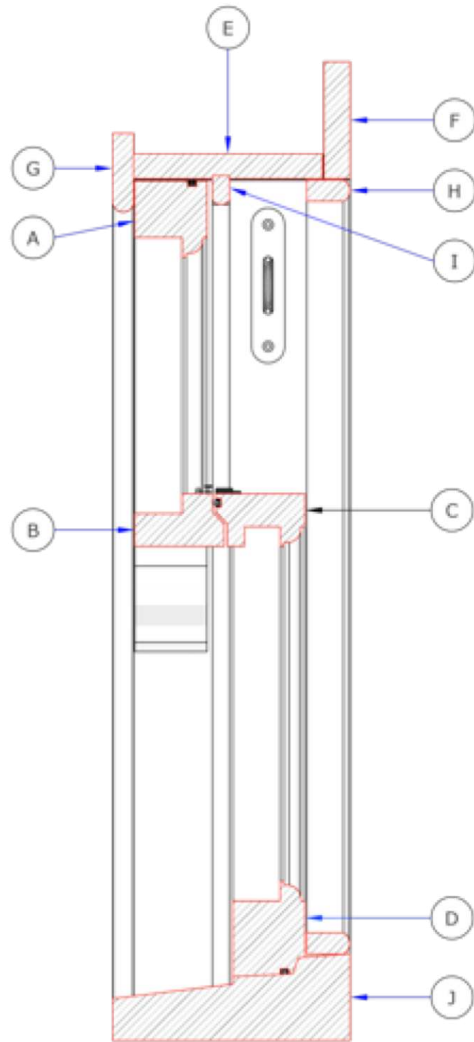

Window-Components

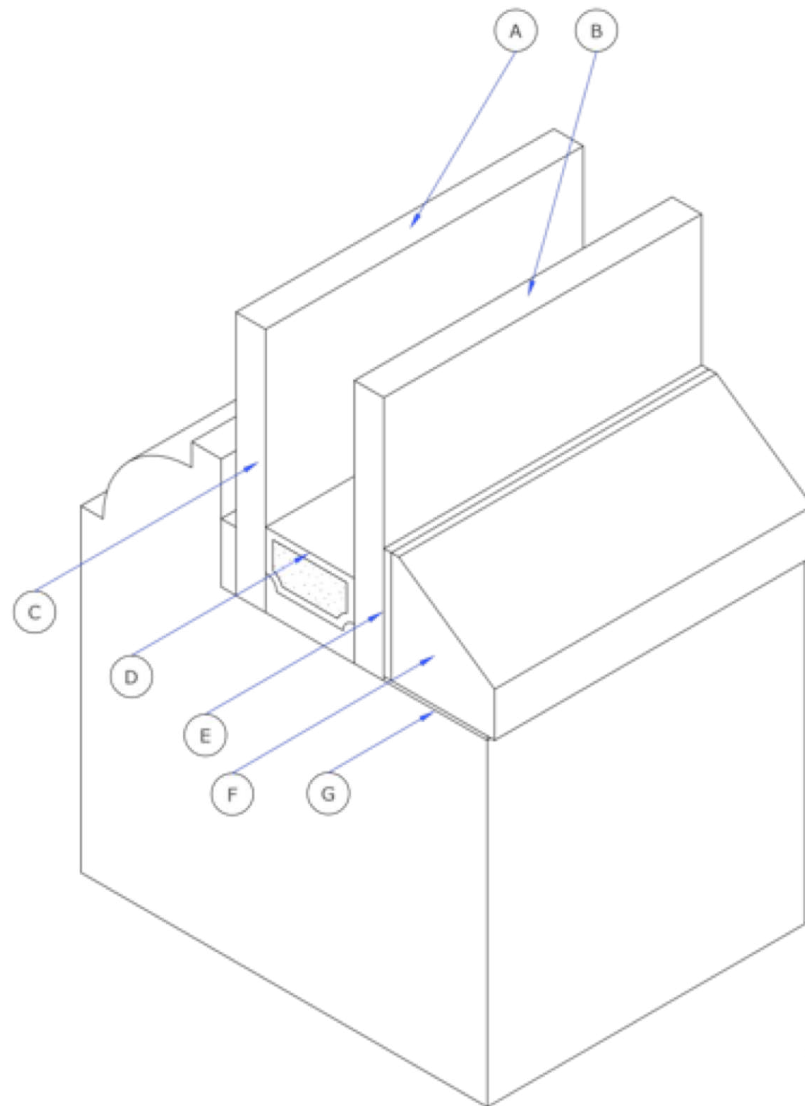

Standard double glazed units

(B) 4mm Super Low 'E'
(D) 12mm Super Spacer - gas filled cavity
(A) 4mm clear. This will create a 20mm unit and a 'U' value of 1.4w/m2K.

- (A) 4mm Float glass
- (B) 4mm Super Low 'E'
- (C) 2mm x 8mm dry glazing tape
- (D) Spacer bar
- (E) 1mm x 15mm Georgian bar tape
- (F) Timber glazing bead
- (G) Silfix U9 Silicone