

DO NOT SCALE: Use figured dimensions only. All dimensions are to be checked on site. Any queries or discrepancies must be reported immediately to the architect.

This drawing is to be read in conjunction with drawings and specifications prepared by the architects and any other information prepared by others for the stated project.

All illustrated material is subject to copyright unless otherwise agreed in writing. This document must be read for the express purpose and project for which it has been created and delivered and must be read with relevant specification clauses.

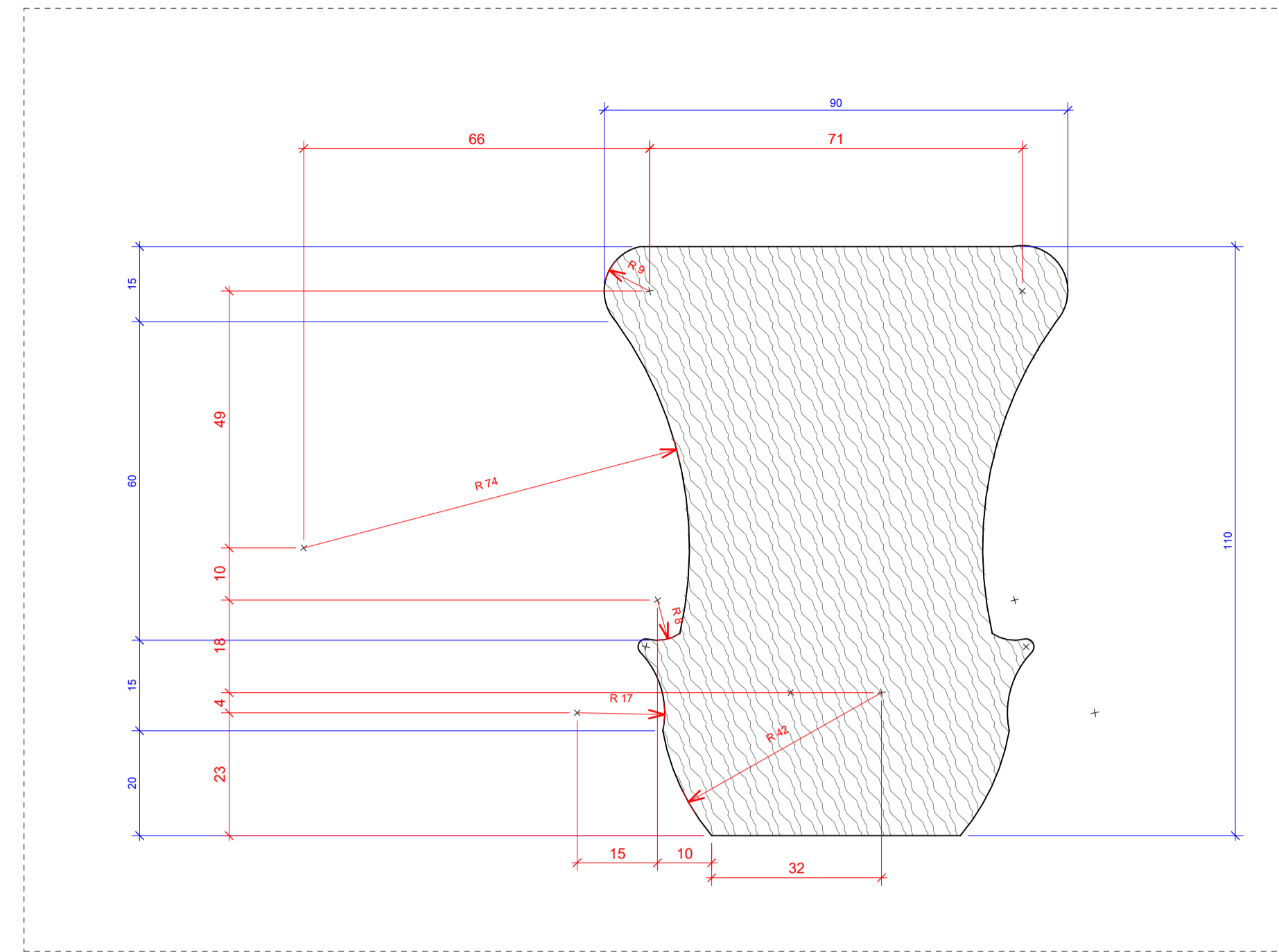

3 LVL 03 - Handrail Profile 2
1:1

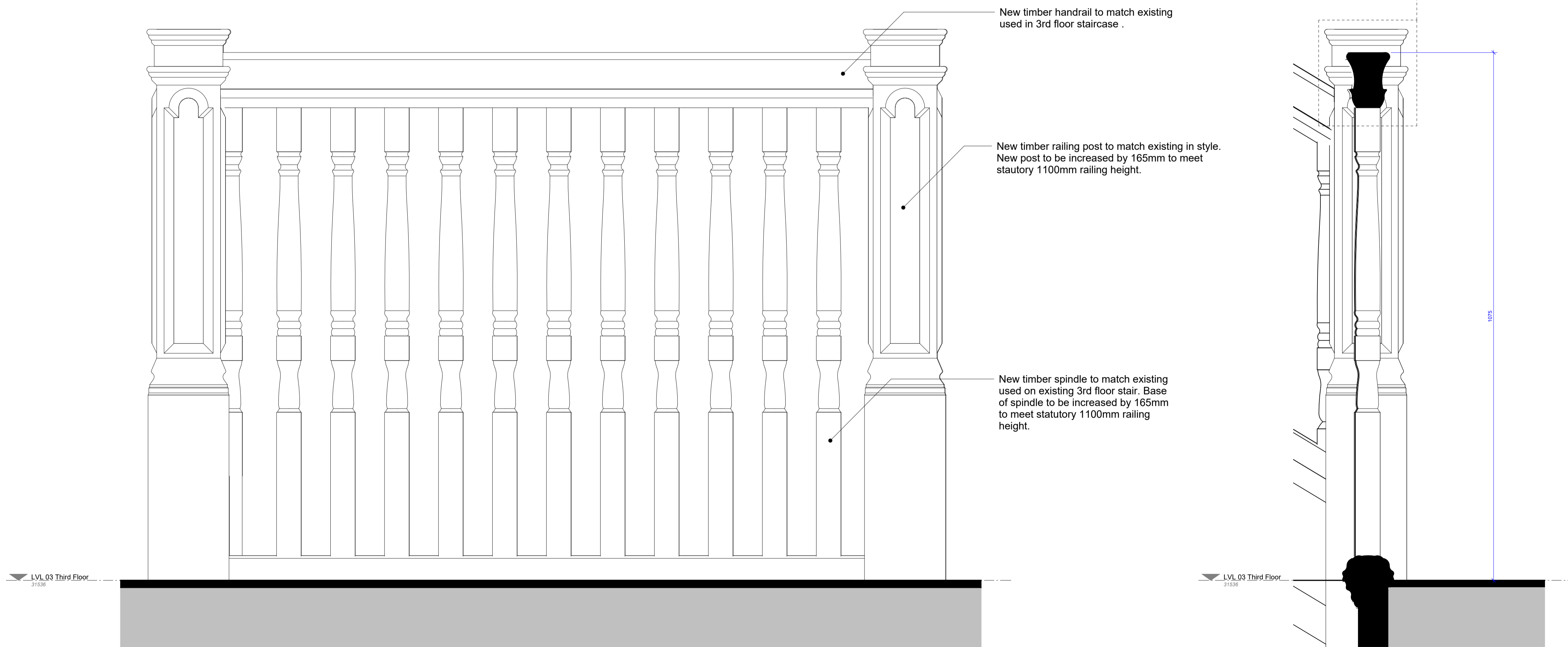

1 LVL 03 - Baluster Elevation
1:5

2 LVL 03 - Baluster Section
1:5

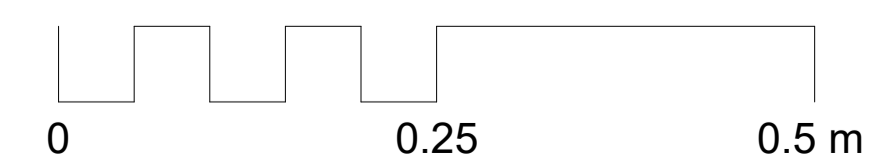

FOR INFORMATION

Revisions			
Rev.	Date	Drawn by	Description

STANESBY
ARCHITECTURE

info@stanesbyarchitecture.co.uk
www.stanesbyarchitecture.co.uk
m: 07917 246 805

Project title

16 Charles Street

Drawing title

Secondary Stair Baluster Detail 3

Date	Drawn by	Checked
01/12/2023	MB	AE
Scale	As indicated @A1	Rev.
Drawing number:	CST-STA-DD-03-DR-A-ST5022	