

**DISCLAIMER**

**A full and accurate measured survey has not been undertaken by Concorde BGW at this site. This drawing has been produced from information provided by others. Any dimensions indicated are for information only and must be checked on site prior to the commencement of any works**



?Crown Copyright and database rights 2023 OS Licence no. 100041041

**SITE LAYOUT PLAN  
 SCALE - 1:500**

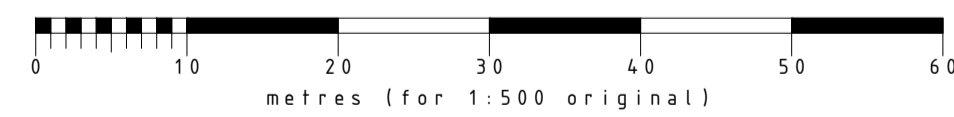

indicates areas of new structure

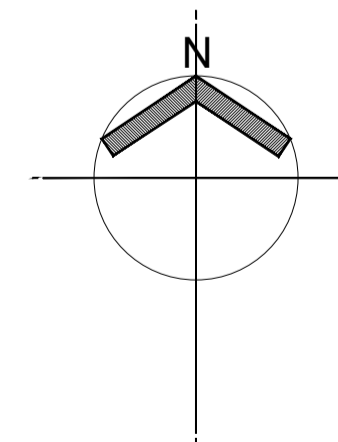

Rev:	Date:	Init:	Note:	© Copyright
------	-------	-------	-------	-------------

Stage: **PLANNING**

Client: **WOOLPACK OPERATING CO LTD**

Project address:  
 Woolpack Inn  
 Totford  
 Alresford  
 SO24 9TJ

Title: **SITE LOCATION PLAN**

Scale: **1:500** Dwg size: **A1**

Drawn by: **BB** Date: **APRIL 24**

Drawing no: **5139-02-02** Rev:

# CONCORDE BGW GROUP

<b>London</b> TOG Albert House 256-260 Old Street Shoreditch, London EC1V 9DD	<b>Doncaster</b> Palmer Street Hyde Park Doncaster DN4 5DD	<b>Nottingham</b> Unit 3, The Glade Business Centre Forum Road Nottingham NG5 9RW
---	--	--